



## **RULES FOR BUILDING AND CLASSING**

---

# **STEEL VESSELS 2006**

### **PART 3 HULL CONSTRUCTION AND EQUIPMENT**

**American Bureau of Shipping  
Incorporated by Act of Legislature of  
the State of New York 1862**

**Copyright © 2005  
American Bureau of Shipping  
ABS Plaza  
16855 Northchase Drive  
Houston, TX 77060 USA**

## Rule Change Notice (2006)

The effective date of each technical change since 1993 is shown in parenthesis at the end of the subsection/paragraph titles within the text of each Part. Unless a particular date and month are shown, the years in parentheses refer to the following effective dates:

(2000) and after	1 January 2000 (and subsequent years)	(1996)	9 May 1996
(1999)	12 May 1999	(1995)	15 May 1995
(1998)	13 May 1998	(1994)	9 May 1994
(1997)	19 May 1997	(1993)	11 May 1993

### Listing by Effective Dates of Changes from the 2005 Rules

Notices No. 1 and 2 (effective on 1 January 2005) and Notice No. 3 (effective on 1 July 2005) to the 2005 Rules, which are incorporated in the 2006 Rules, are summarized below.

#### EFFECTIVE DATE 1 January 2005

(based on the 'keel laying' date or similar stage of construction)

<i>Part/Para. No.</i>	<i>Title/Subject</i>	<i>Status/Remarks</i>
Section 3-2-15	Protection of Deck Openings	To incorporate the updated requirements of IMO Resolution MSC 143(77). (Incorporates Notice No. 1.)
3-2-15/9.1.1	Scantlings	To incorporate the requirements of IACS UI LL70. (Incorporates Notice No. 2.)

#### EFFECTIVE DATE 1 July 2005

(based on the contract date for new construction between builder and Owner)

<i>Part/Para. No.</i>	<i>Title/Subject</i>	<i>Status/Remarks</i>
3-3-1/9 (New)	Onboard Computers for Stability Calculations	To ensure that if stability software is installed on a vessel and used by the Master, it meets the same criteria and accuracy required for the trim and stability booklet. (Incorporates Notice No. 3.)
Appendix 3-3-A1 (New)	Onboard Computers for Stability Calculations	To ensure that if stability software is installed on a vessel and used by the Master, it meets the same criteria and accuracy required for the trim and stability booklet. (Incorporates Notice No. 3.)

#### EFFECTIVE DATE 1 October 2005

(based on the contract date for new construction between builder and Owner)

<i>Part/Para. No.</i>	<i>Title/Subject</i>	<i>Status/Remarks</i>
3-2-7/4	Deck Fittings	Due to the withdrawal of IACS UR A2 (Rev. 1 July 2004), the relevant requirements specified in 3-2-7/4.1, 3-2-7/4.3 and 3-2-7/4.5 are also deleted. (Incorporates Notice No. 4.)
3-5-1/15	Bollard, Fairlead and Chocks	Due to the withdrawal of IACS UR A2 (Rev. 1 July 2004), the relevant requirements specified in 3-5-1/15.1, 3-5-1/15.3 and 3-5-1/15.5 are also deleted. (Incorporates Notice No. 4.)

**EFFECTIVE DATE 1 January 2006**

(based on the contract date for new construction between builder and Owner)

<i>Part/Para. No.</i>	<i>Title/Subject</i>	<i>Status/Remarks</i>
3-2-9/1.3	Openings and Penetrations	To specify the requirements for ventilation penetrations through watertight bulkheads.
3-5-1/11.3.1	Operating Loads	For consistency with 4-5-1/5.1.1(a) for windlass design with the cable stopper attached to the windlass structure.
3-7-1/Table 1	Testing Requirements for Tanks and Boundaries	To align the requirements with IACS UR S14 (Rev. 2) and to clarify that “top of hatch” means “top of hatch coaming” for the purpose of measuring hydrostatic testing head.

This Page Intentionally Left Blank

**Hull Construction and Equipment****CONTENTS**

<b>CHAPTER 1</b>	<b>General</b> .....	<b>1</b>
	Section 1	Definitions .....3
	Section 2	General Requirements.....7
<b>CHAPTER 2</b>	<b>Hull Structures and Arrangements</b> .....	<b>13</b>
	Section 1	Longitudinal Strength .....31
	Section 2	Shell Plating .....67
	Section 3	Decks .....77
	Section 4	Bottom Structures .....85
	Section 5	Frames .....95
	Section 6	Web Frames and Side Stringers..... 103
	Section 7	Beams .....109
	Section 8	Pillars, Deck Girders and Transverses ..... 115
	Section 9	Watertight Bulkheads and Doors ..... 123
	Section 10	Deep Tanks.....135
	Section 11	Superstructures, Deckhouses and Helicopter Decks ..... 139
	Section 12	Machinery Space and Tunnel ..... 147
	Section 13	Stems, Stern Frames and Rudder Horns ..... 151
	Section 14	Rudders ..... 159
	Section 15	Protection of Deck Openings ..... 179
	Section 16	Protection of Shell Openings ..... 197
	Section 17	Bulwarks, Rails, Freeing Ports, Portlights and Ventilators .....211
	Section 18	Ceiling, Sparring and Protection of Steel.....221
	Section 19	Weld Design.....223
	Appendix 1	Calculation of Shear Stresses for Vessels Having Longitudinal Bulkheads.....45
	Appendix 2	Loading Manuals and Loading Instruments.....47

Appendix 3	Loading Manuals and Loading Instruments: Additional Requirements for Bulk Carriers, Ore Carriers and Combination Carriers 150 meters (492 feet) and Above in Length ( $L_f$ ) .....	53
Appendix 4	Buckling Strength of Longitudinal Strength Members .....	59
Appendix 5	Guidelines for Calculating Bending Moment and Shear Force in Rudders and Rudder Stocks .....	173
Appendix 6	Portable Beams and Hatch Cover Stiffeners of Variable Cross Section .....	195
<b>CHAPTER 3</b>	<b>Subdivision and Stability .....</b>	<b>231</b>
Section 1	General Requirements .....	233
Appendix 1	Intact Stability of Tankers During Liquid Transfer Operations .....	235
Appendix 2	Subdivision and Damage Stability Requirements for Bulk Carriers .....	239
Appendix 3	Onboard Computers for Stability Calculations .....	241
<b>CHAPTER 4</b>	<b>Fire Safety Measures .....</b>	<b>249</b>
Section 1	Structural Fire Protection .....	251
<b>CHAPTER 5</b>	<b>Equipment .....</b>	<b>253</b>
Section 1	Anchoring, Mooring and Towing Equipment .....	255
<b>CHAPTER 6</b>	<b>Navigation .....</b>	<b>273</b>
Section 1	Visibility .....	275
<b>CHAPTER 7</b>	<b>Testing, Trials and Surveys During Construction – Hull .....</b>	<b>279</b>
Section 1	Tank, Bulkhead and Rudder Tightness Testing .....	281
Section 2	Trials .....	287
Section 3	Surveys .....	289

**CONTENTS**

<b>SECTION 1</b>	<b>Definitions</b> .....	<b>3</b>
1	Application .....	3
3	Length .....	3
3.1	Scantling Length .....	3
3.3	Freeboard Length.....	3
5	Breadth .....	4
7	Depth .....	4
7.1	Molded Depth.....	4
7.3	Scantling Depth.....	4
9	Draft .....	4
11	Molded Displacement and Block Coefficient .....	4
11.1	Molded Displacement.....	4
11.3	Block Coefficient .....	4
13	Decks .....	5
13.1	Freeboard Deck .....	5
13.3	Bulkhead Deck.....	5
13.5	Strength Deck .....	5
13.7	Superstructure Deck .....	5
15	Deadweight (DWT) and Lightship Weight.....	5
17	Units.....	5
	FIGURE 1 .....	3
<b>SECTION 2</b>	<b>General Requirements</b> .....	<b>7</b>
1	Material and Fabrication .....	7
1.1	Material .....	7
1.3	Application .....	7
3	Application of Steel Materials 51.0 mm (2.00 in.) and Under in Thickness .....	8
3.1	Selection of Material Grade.....	8
3.3	Note for Users .....	8

5	Scantlings .....	10
	5.1 General.....	10
	5.3 Reduced Scantlings with Protective Coatings .....	10
	5.5 Dynamic Loading Approach .....	10
7	Proportions.....	10
9	Workmanship .....	10
11	Drydocking .....	11
13	Structural Sections.....	11
	13.1 General.....	11
	13.3 Deep Supporting Members.....	11
	13.5 Frames, Beams and Stiffeners.....	11
15	Structural Design Details .....	11
	15.1 General.....	11
	15.3 Termination of Structural Members .....	12
	15.5 Fabrication.....	12
TABLE 1	Material Grades.....	8
TABLE 2	Material Class or Grade of Structural Members .....	9



PART

# 3

CHAPTER **1 General**

SECTION **1 Definitions**

## 1 Application

The following definitions of symbols and terms are to be understood (in the absence of other specifications) where they appear in the Rules.

## 3 Length

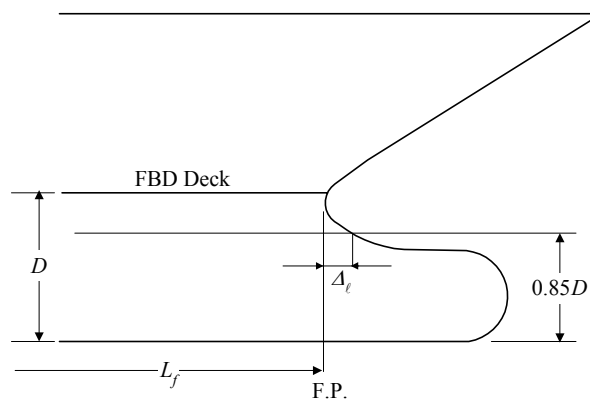
### 3.1 Scantling Length ( $L$ ) (1997)

$L$  is the distance in meters (feet) on the summer load line from the fore side of the stem to the centerline of the rudder stock. For use with the Rules,  $L$  is not to be less than 96% and need not be greater than 97% of the length on the summer load line. The forward end of  $L$  is to coincide with the fore side of the stem on the waterline on which  $L$  is measured.

### 3.3 Freeboard Length ( $L_f$ ) (2002)

$L_f$  is the distance in meters (feet) on a waterline at 85% of the least molded depth measured from the top of the keel from the fore side of the stem to the centerline of the rudder stock or 96% of the length on that waterline, whichever is greater. Where the stem is a fair concave curve above the waterline at 85% of the least molded depth and where the aftermost point of the stem is above the waterline, the forward end of the length,  $L_f$ , is to be taken at the aftermost point of the stem above that waterline. See 3-1-1/Figure 1.

**FIGURE 1**



## 5 Breadth ( $B$ )

$B$  is the greatest molded breadth in meters (feet).

## 7 Depth

### 7.1 Molded Depth ( $D$ ) (1997)

$D$  is the molded depth at side in meters (feet) measured at the middle of  $L$  from the molded base line to the top of the freeboard-deck beams. In vessels having rounded gunwales,  $D$  is to be measured to the point of intersection of the molded lines of the deck and side shell plating. In cases where watertight bulkheads extend to a deck above the freeboard deck and are to be recorded in the *Record* as effective to that deck,  $D$  is to be measured to the bulkhead deck.

### 7.3 Scantling Depth ( $D_s$ ) (1997)

The depth  $D_s$  for use with scantling requirements is the distance in meters (feet) from the molded base line to the strength deck as defined in 3-1-1/13.5.

## 9 Draft ( $d$ )

$d$  is the molded draft, and is the distance in meters (feet) from the molded base line to the summer load line.

## 11 Molded Displacement and Block Coefficient (1997)

### 11.1 Molded Displacement ( $\Delta$ )

$\Delta$  is the molded displacement of the vessel in metric tons (long tons), excluding appendages, taken at the summer load line.

### 11.3 Block Coefficient ( $C_b$ )

$C_b$  is the block coefficient obtained from the following equation:

$$C_b = \Delta / 1.025 L B_{wl} d \quad (\text{SI \& MKS units})$$

$$C_b = 35 \Delta / L B_{wl} d \quad (\text{US units})$$

where

$$\Delta = \text{molded displacement, as defined in 3-1-1/11.1.}$$

$$L = \text{scantling length, as defined in 3-1-1/3.1}$$

$$d = \text{draft, as defined in 3-1-1/9}$$

$$B_{wl} = \text{the greatest molded breadth at summer load line}$$

## 13 Decks

### 13.1 Freeboard Deck

The freeboard deck normally is the uppermost continuous deck having permanent means for closing all openings. Where a vessel is designed for a special draft, considerably less than that corresponding to the least freeboard obtainable under the International Load Line Regulations, the freeboard deck, for the purpose of the Rules, may be taken as the actual lowest deck from which the draft can be obtained under those regulations.

### 13.3 Bulkhead Deck

The bulkhead deck is the highest deck to which the watertight bulkheads extend and are made effective.

### 13.5 Strength Deck

The strength deck is the deck that forms the top of the effective hull girder at any part of its length. See 3-2-1/11.1.

### 13.7 Superstructure Deck

A superstructure deck is a deck above the freeboard deck to which the side shell plating extends. Except where otherwise specified, the term “superstructure deck” where used in the Rules refers to the first such deck above the freeboard deck.

## 15 Deadweight (*DWT*) and Lightship Weight (1997)

For the purpose of these Rules, deadweight, *DWT*, is the difference in metric tons (long tons) between the displacement of the vessel at its summer load line in water having a specific gravity of 1.025 and the lightship weight. For the purpose of these Rules, lightship weight is the displacement of the vessel in metric tons (long tons) with no cargo, fuel, lubricating oil, ballast water, fresh water nor feed water in tanks, no consumable stores, and no passengers or crew nor their effects.

## 17 Units

These Rules are written in three systems of units, viz., SI units, MKS units and US customary units. Each system is to be used independently of any other system.

Unless indicated otherwise, the format of presentation in the Rules of the three systems of units is as follows:

SI units (MKS units, US customary units)

This Page Intentionally Left Blank

PART

# 3

CHAPTER **1 General**

SECTION **2 General Requirements**

## **1 Material and Fabrication**

### **1.1 Material**

#### **1.1.1 Steel**

These Rules are intended for vessels of welded construction using steels complying with the requirements of Part 2, Chapter 1. Use of steels other than those in Part 2, Chapter 1 and the vessels' corresponding scantlings will be specially considered.

#### **1.1.2 Aluminum Alloys**

The use of aluminum alloys in hull structures will be considered upon submission of a specification of the proposed alloys and their proposed method of fabrication.

#### **1.1.3 Design Consideration**

Where scantlings are reduced in association with the use of higher-strength steel or where aluminum alloys are used, adequate buckling strength is to be provided. Where it is intended to use material of cold flanging quality for important longitudinal strength members, this steel is to be indicated on the plans.

#### **1.1.4 Guidance for Repair**

Where a special welding procedure is required for special steels used in the construction, including any low temperature steel and those materials not encompassed in Part 2, Chapter 1, a set of plans showing the following information for each steel is to be placed aboard the vessel:

- Material Specification
- Welding procedure
- Location and extent of application

These plans are in addition to those normally placed aboard the vessel, and are to show all material applications.

### **1.3 Application**

The requirements of the Rules apply to steel vessels of all welded construction. Riveted hull construction, where used, is to comply with the applicable parts dealing with riveting in the 1969 edition of the Rules.

### 3 Application of Steel Materials 51.0 mm (2.00 in.) and Under in Thickness

#### 3.1 Selection of Material Grade

Steel materials for particular locations are not to be of lower grades than those required by 3-1-2/Table 1 for the material class given in 3-1-2/Table 2.

#### 3.3 Note for Users

The attention of users is drawn to the fact that when fatigue loading is present, the effective strength of higher-strength steel in welded construction may not be greater than that of ordinary-strength steel.

Precautions against corrosion fatigue may also be necessary.

**TABLE 1**  
**Material Grades (2000)**

Thickness <i>t</i> mm (in.)	Material Class		
	I	II	III
$t \leq 15$ ( $t \leq 0.60$ )	A <sup>(2)</sup> , AH	A, AH	A, AH
$15 < t \leq 20$ ( $0.60 < t \leq 0.79$ )	A, AH	A, AH	B, AH
$20 < t \leq 25$ ( $0.79 < t \leq 0.98$ )	A, AH	B, AH	D, DH
$25 < t \leq 30$ ( $0.98 < t \leq 1.18$ )	A, AH	D, DH	D <sup>(1)</sup> , DH
$30 < t \leq 35$ ( $1.18 < t \leq 1.38$ )	B, AH	D, DH	E, EH
$35 < t \leq 40$ ( $1.38 < t \leq 1.57$ )	B, AH	D, DH	E, EH
$40 < t \leq 51$ ( $1.57 < t \leq 2.00$ )	D, DH	E, EH	E, EH

*Notes*

- 1 Grade D, of these thicknesses, is to be normalized.
- 2 ASTM A36 steel otherwise tested and certified to the satisfaction of ABS may be used in lieu of Grade A for a thickness up to and including 12.5 mm (0.5 in.) for plate and up to and including 40 mm (1.57 in.) for sections.

**TABLE 2**  
**Material Class or Grade of Structural Members (2003)**

Line No.	Structural members	Within 0.4L Amidships	Outside 0.4L amidships
		Material Class <sup>(8)</sup> or Grade	Material Class or Grade
<b>A</b>	<b>Secondary</b>		
A1	Longitudinal bulkhead strakes, other than those belonging to the Primary category	I	A <sup>(10)</sup> /AH
A2	Deck plating exposed to weather, other than that belonging to the Primary or Special category		
A3	Side plating		
<b>B</b>	<b>Primary</b>		
B1	Bottom plating, including keel plate	II	A <sup>(10)</sup> /AH
B2	Strength deck plating, excluding that belonging to the Special category		
B3	Continuous longitudinal members above strength deck, excluding hatch coamings		
B4	Uppermost strake in longitudinal bulkhead		
B5	Vertical strake (hatch side girder) and uppermost sloped strake in top wing tank		
<b>C</b>	<b>Special</b>		
C1	Sheer strake at strength deck <sup>(1), (9)</sup>	III	II (I outside 0.6L amidships)
C2	Stringer plate in strength deck <sup>(1), (9)</sup>		
C3	Deck strake at longitudinal bulkhead <sup>(2), (9)</sup>		
C4	Strength deck plating at outboard corners of cargo hatch openings in container carriers and other ships with similar hatch opening configurations <sup>(3)</sup>		
C5	Strength deck plating at corners of cargo hatch openings in bulk carriers, ore carriers, combination carriers and other ships with similar hatch opening configurations <sup>(4)</sup>		
C6	Bilge strake <sup>(5), (6), (9)</sup>		
C7	Longitudinal hatch coamings of length greater than 0.15L <sup>(7)</sup>		
C8	End brackets and deck house transition of longitudinal cargo hatch coamings <sup>(7)</sup>		
<b>D</b>	<b>Other Categories</b>		
D1	Stern frames, rudder horns, rudders and shaft brackets	-	II <sup>(11)</sup>
D2	Strength members not referred to in A to C and D1	A <sup>(10)</sup> /AH	A <sup>(10)</sup> /AH

Notes:

- 1 Not to be less than grade E/EH<sup>(9)</sup> within 0.4L amidships in ships with length exceeding 250 m (984 ft)..
- 2 Excluding deck plating in way of inner-skin bulkhead of double hull ships.
- 3 Not to be less than class III within the length of the cargo region.
- 4 Not to be less than class III within 0.6L amidships and class II within the remaining length of the cargo region.
- 5 May be of class II in ships with a double bottom over the full breadth and with length less than 150 m (492 ft).
- 6 Not to be less than grade D/DH within 0.4L amidships in ships with length exceeding 250 m (984 ft).
- 7 Not to be less than grade D/DH.
- 8 Special consideration will be given to vessels of restricted class.
- 9 Single strake required to be class III or E/EH are to have breadths not less than 800 + 5L mm (31.5 + 0.06L in.), but need not exceed 1800 mm (71 in.), unless limited by the geometry of the vessel's design.
- 10 ASTM A36 steel otherwise tested and certified to the satisfaction of ABS may be used in lieu of Grade A for a thickness up to and including 12.5 mm (0.5 in.) for plates and up to and including 40 mm (1.57 in.) for sections.
- 11 For rudder and rudder body plates subjected to stress concentrations (e.g., in way of lower support or at upper part of spade rudders), class III is to be applied.

## 5 Scantlings

### 5.1 General

The midship scantlings specified in the Rules are to apply throughout the midship  $0.4L$ . End scantlings are not to extend for more than  $0.1L$  from each end of the vessel. Reduction in scantlings from the midship to the end scantlings is to be effected in as gradual a manner as practicable. Sections having appropriate section moduli or areas, in accordance with their functions in the structure as stiffeners, columns or combinations of both, are to be adopted, due regard being given to the thickness of all parts of the sections to provide a proper margin for corrosion. It may be required that calculations be submitted in support of resistance to buckling for any part of the vessel's structure.

### 5.3 Reduced Scantlings with Protective Coatings

Where deemed necessary, to suit a particular type and/or service of a vessel or a space, a reduction in scantlings in association with protective coatings may be considered. In such instances, a justification for the reduction is to be submitted for review, together with particulars of the coating. A program for maintenance is to be submitted. The plans are to show the required scantlings and the proposed scantlings, both suitably identified. Where any of the proposed reductions are approved, a notation will be made in the *Record* that such reductions have been taken.

### 5.5 Dynamic Loading Approach

The symbols **SH-DLA** are assigned to vessels which have been reviewed based upon an acceptable load and structural analysis procedure, taking into consideration the dynamic load components acting on the vessel.

The dynamic load components considered are to include the external hydrodynamic pressure loads, dynamic loads from cargoes and inertial loads of the hull structure. The magnitude of the load components and their combinations are to be determined from appropriate ship motion response calculations for loading conditions which represent the envelope of maximum dynamically induced stresses in the vessel.

The adequacy of the hull structure for all combinations of the dynamic loadings is to be evaluated using an acceptable finite element analysis method.

In no case are the structural scantlings to be less than those obtained from other requirements in the Rules.

## 7 Proportions

In general, these Rules are valid for all vessels not exceeding 500 m (1640 ft) in length,  $L$ , and having a breadth,  $B$ , not exceeding one-fifth of the length,  $L$ , nor 2.5 times the depth,  $D_s$ , to the strength deck. Vessels beyond these proportions will be specially considered.

## 9 Workmanship

All workmanship is to be of commercial marine quality and acceptable to the Surveyor. Welding is to be in accordance with the requirements of Part 2, Chapter 4.



## 11 Drydocking

Consideration is to be given to drydocking the vessel within twelve months after delivery. For vessels 228.5 m (750 ft) in length,  $L$ , and over, information indicating docking arrangements is to be prepared and furnished onboard the vessel for guidance.

## 13 Structural Sections (1993)

### 13.1 General

The scantling requirements of these Rules are applicable to structural angles, channels, bars, and rolled or built-up sections.

### 13.3 Deep Supporting Members (1993)

The required section modulus of members such as girders, webs, etc., supporting frames, beams and stiffeners, is to be obtained on an effective width of plating basis in accordance with this subsection. The section is to include the structural member in association with an effective width of plating not exceeding one-half of the sum of the spacing on each side of the member or 33% of the unsupported span  $\ell$ , whichever is less. For girders and webs along hatch openings, an effective breadth of plating not exceeding one-half of the spacing or 16.5% of the unsupported span  $\ell$ , whichever is less, is to be used.

### 13.5 Frames, Beams and Stiffeners (1993)

#### 13.5.1 Section Modulus

The required section modulus is to be provided by the stiffener and a maximum of one frame space of the plating to which it is attached.

#### 13.5.2 Web Thickness

The depth to thickness ratio of the web portion of members is not to exceed the following:

Members with flange	$50C_1C_2$
Members without flange	$15C_1C_2$

where

$C_1$	=	0.95 (horizontal web within a tank)
	=	1.0 (all other cases)
$C_2$	=	1.0 (ordinary strength steel)
	=	0.92 (HT32)
	=	0.90 (HT36)

## 15 Structural Design Details

### 15.1 General

The designer is to give consideration to the following:

- i) The thickness of internals in locations susceptible to rapid corrosion.
- ii) The proportions of built-up members for compliance with established standards for structural stability. See 3-1-2/13.5.2 and Appendix 3-2-A4.

- iii) The design of structural details, such as noted below, against the harmful effects of stress concentrations and notches:
- Details of the ends, at the intersections of members and associated brackets.
  - Shape and location of air, drainage, and/or lightening holes.
  - Shape and reinforcement of slots or cut-outs for internals.
  - Elimination or closing of weld scallops in way of butts, “softening” of bracket toes, reducing abrupt changes of section or structural discontinuities.
- iv) Proportions and thickness of structural members to reduce fatigue response due to engine, propeller or wave-induced cyclic stresses, particularly for higher-strength steels.
- A booklet of standard construction details based on the above considerations is to be submitted for review and comment.

### 15.3 Termination of Structural Members (1998)

Unless permitted elsewhere in the Rules, structural members are to be effectively connected to adjacent structures in such a manner as to avoid hard spots, notches and other harmful stress concentrations.

Where load-bearing members are not required to be attached at their ends, special attention is to be given to the end taper, by using a sniped end of not more than 30°.

Where the member has a face bar or flange, it is to be sniped and tapered not more than 30°.

The end brackets of large primary load-bearing members are to be soft-toed. Where any end bracket has a face bar it is to be sniped and tapered not more than 30°.

Bracket toes and sniped end members are to be kept within 25 mm (1.0 in.) of the adjacent member, unless the bracket or member is supported by another member on the opposite side of the plating. The depth of toe or sniped end is generally not to exceed 15 mm (0.60 in.).

Where a strength deck or shell longitudinal terminates without an end attachment, the longitudinal is to extend into the adjacent transversely framed structure, or stop at a local transverse member fitted at about one transverse frame space (see 3-2-5/1.5) beyond the last floor or web that supports the longitudinal.

The end attachments of non-load bearing members may, in general, be snipe ended. The sniped end is to be not more than 30° and is to be kept generally within 40 mm (1.57 in.) of the adjacent member unless it is supported by a member on the opposite side of the plating. The depth of the toe is generally not to exceed 15 mm (0.6 in.).

### 15.5 Fabrication (1 July 2001)

Structural fabrication is to be carried out in accordance with a recognized standard to the satisfaction of the attending Surveyor. If a recognized national standard or an appropriate shipbuilding and repair standard is not available, the ABS publication, *Guide for Shipbuilding and Repair Quality Standard for Hull Structures During Construction*, may be used. See Part 5, Appendix 1 “Guide for SafeHull Construction Monitoring Program”.

**CONTENTS**

<b>SECTION 1</b>	<b>Longitudinal Strength.....</b>	<b>31</b>
1	Application .....	31
3	Longitudinal Hull Girder Strength.....	31
3.1	Sign Convention of Bending Moment and Shear Force.....	31
3.3	Still-water Bending Moment and Shear Force.....	31
3.5	Wave Loads .....	33
3.7	Bending Strength Standard.....	36
3.9	Shearing Strength .....	37
5	Longitudinal Strength with Higher-Strength Materials .....	39
5.1	General .....	39
5.3	Hull Girder Moment of Inertia .....	40
5.5	Hull Girder Section Modulus .....	40
5.7	Hull girder Shearing Force .....	40
7	Loading Guidance.....	40
7.1	Loading Manual and Loading Instrument.....	40
7.3	Allowable Stresses.....	40
9	Section Modulus Calculation .....	41
9.1	Items Included in the Calculation .....	41
9.3	Effective Areas Included in the Calculation .....	41
9.5	Section Modulus to the Deck or Bottom .....	41
9.7	Section Modulus to the Top of Hatch Coamings .....	41
11	Strength Decks .....	42
11.1	Definition .....	42
11.3	Tapering of Deck Sectional Areas.....	42
13	Continuous Longitudinal Hatch Coamings and Above Deck Girders .....	42
15	Effective Lower Decks .....	42
17	Longitudinal Deck Structures Inboard of Lines of Openings.....	42
17.1	General .....	42
17.3	Effectiveness.....	43
19	Buckling Strength.....	43

FIGURE 1	Sign Convention.....	34
FIGURE 2	Distribution Factor $M$ .....	35
FIGURE 3	Distribution Factor $F_1$ .....	35
FIGURE 4	Distribution Factor $F_2$ .....	36
FIGURE 5	Shear Force Distribution .....	39
FIGURE 6	Effective Area of Hull Girder Members .....	44
<b>SECTION 2</b>	<b>Shell Plating .....</b>	<b>67</b>
1	Application.....	67
3	Shell Plating Amidships .....	67
3.1	Vessels with No Partial Superstructures Above Uppermost Continuous Deck.....	67
3.3	Superstructures Fitted Above Uppermost Continuous Deck (Side Plating Extended).....	67
3.5	Superstructures Fitted Above Uppermost Continuous Deck (Side Plating Not Extended) .....	67
3.7	In Way of Comparatively Short Superstructures.....	68
3.9	Side Shell Plating .....	68
3.11	Sheer Strake.....	68
3.13	Bottom Shell Plating Amidships.....	69
3.15	Flat Plate Keel .....	70
3.17	Minimum Thickness.....	71
5	Shell Plating at Ends.....	71
5.1	Minimum Shell Plating Thickness .....	71
5.3	Immersed Bow Plating.....	72
5.5	Bottom Forward .....	72
5.7	Forecastle Side Plating.....	73
5.9	Poop Side Plating .....	73
5.11	Bow and Stern Thruster Tunnels .....	73
5.13	Special Heavy Plates.....	74
7	Bottom Shell Plating for Special Docking Arrangement .....	74
9	Compensation .....	74
11	Breaks .....	75
13	Bilge Keels .....	75
15	Higher-strength Materials.....	75
15.1	General.....	75
15.3	Bottom Plating of Higher-strength Material .....	75
15.5	Side Plating of Higher-strength Material .....	76
15.7	End Plating .....	76
<b>SECTION 3</b>	<b>Decks .....</b>	<b>77</b>
1	General .....	77
1.1	Extent of Plating .....	77
3	Hull Girder Strength .....	77
3.1	Longitudinal Section Modulus Amidships .....	77
3.3	Strength Deck.....	77

	3.5	Longitudinally Framed Decks.....	77
	3.7	Superstructure Decks.....	77
	3.9	Deck Transitions .....	78
	3.11	Deck Plating.....	78
5		Deck Plating.....	78
	5.1	Thickness.....	78
	5.3	Effective Lower Decks.....	78
	5.5	Reinforcement at Openings .....	78
	5.7	Platform Decks.....	79
	5.9	Superstructure Decks.....	79
	5.11	Decks Over Tanks.....	79
	5.13	Watertight Flats .....	79
	5.15	Retractable Tween Decks .....	79
	5.17	Wheel Loading .....	80
7		Higher-strength Material .....	84
	7.1	Thickness.....	84
	7.3	Wheel Loading .....	84
9		Deck Covering Compositions .....	84

TABLE 1	Applicable Thickness Equations .....	81
---------	--------------------------------------	----

TABLE 2	Minimum Thickness Equations .....	82
---------	-----------------------------------	----

FIGURE 1	Wheel Loading Curves of “K” .....	83
----------	-----------------------------------	----

#### **SECTION 4 Bottom Structures.....85**

1		Double Bottoms .....	85
	1.1	General .....	85
	1.3	Testing .....	85
3		Center and Side Girders .....	85
	3.1	Center Girders.....	85
	3.3	Pipe Tunnels ( <i>Note: An alternative arrangement of center girders</i> ).....	86
	3.5	Docking Brackets ( <i>Note: Not only for center girder but also for side girders</i> ).....	86
	3.7	Side Girders .....	86
5		Solid Floors .....	87
	5.1	General .....	87
	5.3	Tank-end Floors.....	87
	5.5	Floor Stiffeners.....	87
7		Open Floors .....	88
	7.1	General .....	88
	7.3	Frames and Reverse Frames.....	88
	7.5	Center and Side Brackets .....	88
	7.7	Struts.....	88
9		Inner-bottom Plating.....	89
	9.1	Inner-bottom Plating Thickness.....	89
	9.3	Center Strakes .....	89

9.5	Under Boilers .....	89
9.7	In Way of Engine Bed Plates or Thrust Blocks .....	89
9.9	Margin Plates.....	90
9.11	Recommendations Where Cargo is Handled by Grabs.....	90
9.13	Wheel Loading.....	90
11	Bottom and Inner-bottom Longitudinals .....	90
11.1	General.....	90
11.3	Bottom Longitudinals .....	90
11.5	Inner-bottom Longitudinals.....	91
13	Fore-end Strengthening .....	91
13.1	General.....	91
13.3	Extent of Strengthening .....	92
13.5	Longitudinal Framing .....	92
13.7	Transverse Framing .....	92
15	Higher-strength Materials.....	93
15.1	General.....	93
15.3	Inner-bottom Plating .....	93
15.5	Bottom and Inner-bottom Longitudinals.....	94
15.7	Center Girders, Side Girders, and Floors .....	94
17	Structural Arrangements and Details.....	94
17.1	Structural Sea Chests.....	94
17.3	Drainage .....	94
17.5	Manholes and Lightning Holes .....	94
17.7	Air and Drainage Holes .....	94
TABLE 1.....		92
TABLE 2 Spacing of Floors .....		93
FIGURE 1 Double-bottom Solid Floors .....		87
FIGURE 2 Double-bottom Open Floors.....		89

**SECTION 5 Frames .....** **95**

1	General .....	95
1.1	Basic Considerations.....	95
1.3	Holes in Frames .....	95
1.5	End Connections .....	95
1.7	Standard and Cant Frame Spacing .....	95
3	Hold Frames.....	96
3.1	Transverse Frames .....	96
3.3	Raised Quarter Decks .....	97
3.5	Fore-end Frames.....	97
3.7	Panting Frames .....	97
3.9	Side Stringers .....	97
3.11	Frames with Web Frames and Side Stringers .....	98
3.13	Panting Webs and Stringers .....	98

	3.15	Hold Frame Brackets .....	98
	3.17	Longitudinal Frames.....	98
	3.19	Machinery Space .....	98
5		Tween-deck Frames .....	100
	5.1	General .....	100
	5.3	Transverse Tween-deck Frames.....	100
	5.5	Longitudinal Tween-deck Frames .....	101
7		Forepeak Frames.....	101
	7.1	General .....	101
	7.3	Frame Scantlings .....	101
9		After-peak Frames .....	102
	9.1	General .....	102
	9.3	Frame Scantlings .....	102
	9.5	Vessels of High Power or Fine Form.....	102
	FIGURE 1	Zones of Framing .....	96
	FIGURE 2	Hold Frames.....	99
	FIGURE 3	Hold Frames.....	99
	FIGURE 4	Hold Frames.....	99

## **SECTION 6 Web Frames and Side Stringers ..... 103**

1		General .....	103
3		Web Frames .....	103
	3.1	Hold Web Frames Amidships and Aft .....	103
	3.3	Hold Web Frames Forward .....	104
	3.5	Proportions.....	105
	3.7	Stiffeners.....	105
	3.9	Tripping Bracket.....	105
	3.11	Tween-deck Webs .....	105
5		Side Stringers .....	105
	5.1	Hold Stringers .....	105
	5.3	Proportions.....	105
	5.5	Stiffeners.....	106
	5.7	Tripping Brackets .....	106
7		Structural Arrangements and Details.....	106
	7.1	Brackets of Girders, Webs, and Stringers .....	106
	7.3	End Connections.....	106
9		Peak Stringers .....	106
	9.1	Peak Stringer-plate Thickness .....	106
	9.3	Peak Stringer-plate Breadth .....	107

	FIGURE 1	Hold Web-frame Arrangements .....	104
--	----------	-----------------------------------	-----

<b>SECTION 7</b>	<b>Beams</b> .....	<b>109</b>
1	General .....	109
	1.1 Arrangement.....	109
	1.3 Design Head.....	109
3	Beams .....	110
	3.1 Strength Requirement .....	110
	3.3 Special Heavy Beams .....	111
	3.5 Beams at the Head of Web Frames .....	111
	3.7 End Connections .....	111
4	Deck Fittings .....	112
	4.1 General.....	112
	4.3 Design Loads.....	112
	4.5 Supporting Structures.....	112
5	Container Loading.....	112
	5.1 General.....	112
	5.3 Strength Requirements.....	112
7	Higher-strength Materials.....	113
	7.1 General.....	113
	7.3 Beams of Higher-strength Materials .....	113
TABLE 1	Values of $h$ for Beams .....	109
TABLE 2	Values of $f$ (Ordinary-strength Steel) .....	113

<b>SECTION 8</b>	<b>Pillars, Deck Girders and Transverses</b> .....	<b>115</b>
1	General .....	115
	1.1 Arrangements – General .....	115
	1.3 Container Loading .....	115
3	Pillars .....	115
	3.1 Permissible Load .....	115
	3.3 Calculated Load.....	116
	3.5 Special Pillars .....	116
	3.7 Pillars Under the Tops of Deep Tanks.....	117
	3.9 Bulkhead Stiffening.....	117
	3.11 Attachments.....	117
5	Deck Girders and Transverses .....	117
	5.1 General.....	117
	5.3 Deck Girders Clear of Tanks .....	117
	5.5 Deck Transverses Clear of Tanks .....	118
	5.7 Proportions .....	119
	5.9 Tripping Brackets.....	119
	5.11 End Attachments .....	119
	5.13 Deck Girders and Transverses in Tanks .....	119
	5.15 Hatch Side Girders .....	119
7	Hatch-end Beams .....	119
	7.1 Hatch-end Beam Supports .....	119
	7.3 Weather Deck Hatch-end Beams .....	120



	7.5	Depth and Thickness .....	120
	7.7	Tripping Brackets .....	120
	7.9	Brackets .....	120
9		Higher-strength Materials .....	121
	9.1	General .....	121
	9.3	Girders and Deck Transverses.....	122
FIGURE 1		Deck Girders and Pillars .....	118
FIGURE 2		Hatch-end Beams .....	121

## **SECTION 9 Watertight Bulkheads and Doors ..... 123**

1		General .....	123
	1.1	Application .....	123
	1.3	Openings and Penetrations.....	123
	1.5	Sluice Valves and Cocks.....	123
	1.7	Strength Bulkheads.....	123
	1.9	Testing .....	124
3		Arrangement of Watertight Bulkheads.....	124
	3.1	Collision Bulkhead.....	124
	3.3	After-peak Bulkhead.....	124
	3.5	Machinery Spaces.....	125
	3.7	Hold Bulkheads .....	126
	3.9	Chain Lockers .....	126
5		Construction of Watertight Bulkheads .....	126
	5.1	Plating .....	126
	5.3	Stiffeners.....	127
	5.5	Attachments .....	129
	5.7	Girders and Webs .....	129
7		Construction of Corrugated Bulkheads.....	130
	7.1	Plating .....	130
	7.3	Stiffeners.....	130
	7.5	End Connections.....	130
9		Watertight Doors .....	132
	9.1	Doors Used While at Sea.....	132
	9.3	Access Doors Normally Closed at Sea .....	132
	9.5	Doors or Ramps Dividing Large Cargo Spaces .....	132
	9.7	Other Openings Closed at Sea .....	132
	9.9	Construction.....	133
	9.11	Testing at Sliding Door Manufacturer.....	133
TABLE 1		Thickness and Flanges of Brackets and Knees.....	128
FIGURE 1		Collision Bulkhead in Vessels with Bow Door.....	125
FIGURE 2		Reference Point for Vessels with Bulbous Bow.....	125
FIGURE 3		Corrugated Bulkhead .....	130
FIGURE 4		Corrugated Bulkhead End Connections .....	131
FIGURE 5		Corrugated Bulkhead Upper Stool Credit .....	131

<b>SECTION 10 Deep Tanks.....</b>	<b>135</b>
1    General .....	135
1.1    Application .....	135
1.3    Arrangement.....	135
1.5    Construction .....	135
1.7    Drainage and Air Escape.....	135
1.9    Testing.....	135
3    Construction of Deep Tank Bulkheads .....	136
3.1    Plating .....	136
3.3    Stiffeners .....	136
3.5    Tank-top Plating .....	137
3.7    Girders and Webs.....	137
3.9    Corrugated Bulkheads.....	138
5    Higher-strength Materials.....	138
5.1    General.....	138
5.3    Plating .....	138
5.5    Stiffeners .....	138
 <b>SECTION 11 Superstructures, Deckhouses and Helicopter Decks ....</b>	 <b>139</b>
1    General Scantlings of Superstructures and Deckhouses .....	139
1.1    Side Plating .....	139
1.3    Decks .....	139
1.5    Frames .....	139
1.7    Breaks in Continuity.....	139
3    Exposed Bulkheads .....	140
3.1    General.....	140
3.3    Plating .....	140
3.5    Stiffeners .....	140
3.7    End Attachments .....	141
3.9    Raised Quarter Deck Bulkheads .....	141
5    Enclosed Superstructures.....	143
5.1    Openings in Bulkheads.....	143
5.3    Doors for Access Openings.....	143
5.5    Sills of Access Openings .....	143
5.7    Portlights .....	143
5.9    Bridges and Poops .....	143
7    Open Superstructures.....	143
9    Forecastle Structures.....	143
11   Helicopter Decks.....	144
11.1   General.....	144
11.3   Structure.....	144
11.5   Safety Net.....	145
11.7   Material.....	145
11.9   Means of Escape and Access .....	146

TABLE 1	Values of $a$ .....	142
TABLE 2	Values of $f$ .....	142
TABLE 3	Allowable Factors of Safety Based on $Y$ for Helicopter Decks .....	145

## **SECTION 12 Machinery Space and Tunnel..... 147**

1	General .....	147
1.1	Arrangement .....	147
1.3	Testing of Tunnels.....	147
3	Engine Foundations .....	147
3.1	Engine Foundations in Double-bottom Vessels.....	147
3.3	Boiler Foundations .....	148
3.5	Thrust Foundations .....	148
3.7	Shaft Stools and Auxiliary Foundations.....	148
5	Tunnels and Tunnel Recesses .....	148
5.1	Plating .....	148
5.3	Stiffeners.....	148
5.5	Beams, Pillars and Girders .....	149
5.7	Tunnels Through Deep Tanks.....	149

## **SECTION 13 Stems, Stern Frames and Rudder Horns ..... 151**

1	Stems .....	151
1.1	Plate Stems.....	151
1.3	Cast-steel Stems.....	151
3	Stern Frames .....	151
3.1	General .....	151
3.3	Rudder Gudgeons.....	151
3.5	Scantlings Below the Propeller Boss.....	152
3.7	Stern Frames with Shoe Piece.....	153
3.9	Above the Boss .....	153
3.11	Secondary Members .....	153
3.13	Shoe Pieces.....	154
5	Rudder Horns.....	155
5.1	Scantlings – Single Pintle Rudders .....	155
5.3	Scantlings – Two Pintle Rudders .....	156
5.5	Floors .....	157
5.7	Shell Plating.....	157
5.9	Water Exclusion .....	157
7	Inspection of Castings.....	157
FIGURE 1	Stern Frame .....	152
FIGURE 2	Shoe Piece.....	155
FIGURE 3	Rudder Horn.....	158

<b>SECTION 14 Rudders .....</b>	<b>159</b>
1    General .....	159
1.1    Application .....	159
1.3    Rudder and Rudder Stock Materials .....	159
1.5    Expected Torque .....	159
1.7    Rudder Stops .....	160
3    Design Rudder Force .....	160
3.1    Rudders without Cutouts .....	160
3.3    Rudders with Cutouts .....	161
5    Design Rudder Torque for Scantlings .....	163
5.1    General .....	163
5.3    Rudders without Cutouts .....	163
5.5    Rudders with Cutouts .....	163
5.7    Trial Conditions .....	164
7    Rudder Stocks .....	164
7.1    Upper Rudder Stocks .....	164
7.3    Lower Rudder Stocks .....	164
9    Flange Couplings .....	164
9.1    General .....	164
9.3    Horizontal Couplings .....	165
9.5    Vertical Couplings .....	165
11   Tapered Stock Couplings .....	166
11.1   Taper Ratio .....	166
11.3   Keying .....	166
11.5   Locking Nut .....	166
13   Keyless Couplings .....	167
15   Pintles .....	167
15.1   General .....	167
17   Supporting and Anti-Lifting Arrangements .....	168
17.1   Rudder Stock and Pintle Bearings .....	168
17.3   Rudder Carrier .....	168
17.5   Anti-lifting Devices .....	168
19   Double Plate Rudder .....	169
19.1   Strength .....	169
19.3   Side, Top and Bottom Plating .....	170
19.5   Diaphragm Plates .....	171
19.7   Watertightness .....	171
21   Single Plate Rudders .....	171
21.1   Mainpiece Diameter .....	171
21.3   Blade Thickness .....	171
21.5   Arms .....	171
TABLE 1	Section Shape Coefficients .....
TABLE 2	Bearing Pressure .....

FIGURE 1	Rudder without Cutouts .....	162
FIGURE 2	Rudder with Cutouts .....	162
FIGURE 3	Tapered Couplings.....	166
FIGURE 4	.....	170

**SECTION 15 Protection of Deck Openings..... 179**

1	General .....	179
3	Positions and Design Pressures.....	179
3.1	Positions of Deck Openings .....	179
3.3	Design Pressures.....	179
5	Hatchway Coamings.....	181
5.1	Height of Coamings.....	181
5.3	Coaming Plates.....	181
5.5	Coaming Stiffening.....	181
5.7	Protection of Coaming Edges .....	181
5.9	Continuous Longitudinal Hatch Coamings .....	181
7	Hatchways Closed by Portable Covers and Secured Weathertight by Tarpaulins and Battening Devices.....	182
7.1	Pontoon Covers .....	182
7.3	Wood Hatch Covers .....	183
7.5	Steel Hatch Covers .....	183
7.7	Bearing Surface .....	184
7.9	Materials Other Than Steel .....	184
9	Hatchways Closed by Covers of Steel Fitted with Gaskets and Clamping Devices.....	184
9.1	Strength of Covers .....	184
9.3	Other Materials.....	184
9.5	Means for Securing Weathertightness .....	184
9.7	Flush Hatch Covers.....	185
9.9	Container Loading.....	185
11	Hatchways in Decks at Higher Levels .....	186
11.1	Gasketless Covers .....	186
13	Hatchways in Lower Decks or within Fully Enclosed Superstructures.....	186
13.1	General .....	186
13.3	Beams and Wood Covers .....	186
13.5	Steel Covers .....	186
13.7	Wheel Loading .....	187
14	Small Hatches on the Exposed Fore Deck.....	187
14.1	Application .....	187
14.3	Strength .....	187
14.5	Primary Securing Devices.....	187
14.7	Requirements for Primary Securing .....	188
14.9	Secondary Devices .....	188
15	Other Hatchways .....	190
15.1	Hatchways within Open Superstructures .....	190
15.3	Hatchways within Deckhouses.....	190

17	Additional Requirements for Subdivision .....	191
17.1	External Opening below Damage Waterline .....	191
17.3	Internal Openings .....	191
19	Machinery Casings .....	191
19.1	Arrangement.....	191
19.3	Fiddleys, Funnels, and Ventilators.....	191
19.5	Casings within Open Superstructures .....	191
19.7	Casings within Enclosed Superstructures .....	191
19.9	Casings within Deckhouses.....	192
21	Miscellaneous Openings in Freeboard and Superstructure Decks .....	192
21.1	Manholes and Scuttles .....	192
21.3	Other Openings .....	192
21.5	Escape Openings .....	193
21.7	Companionway Sills .....	193
21.9	Mast Openings .....	193
21.11	Chain Pipe Opening .....	193

TABLE 1	Scantlings for Small Steel Hatch Covers on the Fore Deck.....	188
---------	------------------------------------------------------------------	-----

FIGURE 1	Arrangement of Stiffeners .....	189
----------	---------------------------------	-----

FIGURE 2	Example of Primary Securing Method .....	190
----------	------------------------------------------	-----

## **SECTION 16 Protection of Shell Openings..... 197**

1	Cargo, Gangway, or Fueling Ports .....	197
1.1	Construction .....	197
1.3	Location.....	197
1.5	Subdivision Requirements.....	197
3	Bow Doors, Inner Doors, Side Shell Doors and Stern Doors .....	198
3.1	General.....	198
3.3	Arrangement.....	198
5	Securing, Locking and Supporting of Doors .....	198
5.1	Definitions.....	198
7	Securing and Supporting Devices .....	199
7.1	General.....	199
7.3	Bow Doors.....	199
7.5	Side Shell and Stern Doors .....	199
9	Securing and Locking Arrangement .....	199
9.1	General.....	199
9.3	Operation.....	200
11	Tightness.....	200
11.1	Bow Doors .....	200
11.3	Inner Doors.....	200
11.5	Side Shell and Stern Doors .....	200

13	Bow Door Scantlings.....	200
	13.1 General .....	200
	13.3 Primary Structure .....	200
	13.5 Secondary Stiffeners.....	200
	13.7 Plating .....	201
	13.9 Securing and Supporting Devices.....	201
	13.11 Visor Door Lifting Arms and Supports .....	201
15	Inner Door Scantlings .....	202
	15.1 General .....	202
	15.3 Primary Structure .....	202
	15.5 Securing and Supporting Devices.....	202
17	Side Shell Door and Stern Door Scantlings.....	202
	17.1 General .....	202
	17.3 Primary Structure .....	202
	17.5 Secondary Stiffeners.....	202
	17.7 Plating .....	202
	17.9 Securing and Supporting Devices.....	203
19	Bow Door Design Loads .....	203
	19.1 External Pressure.....	203
	19.3 External Forces .....	204
	19.5 Visor Door Forces, Moments and Load Cases.....	206
	19.7 Side-Opening Door Load Cases .....	207
21	Inner Door Design Loads.....	207
	21.1 External Pressure.....	207
	21.3 Internal Pressure.....	207
23	Side Shell and Stern Doors .....	208
	23.1 Design Forces for Primary Members.....	208
	23.3 Design Forces for Securing or Supporting Devices of Doors Opening Inwards .....	208
	23.5 Design Forces for Securing or Supporting Devices of Doors Opening Outwards.....	208
25	Allowable Stresses.....	209
	25.1 Primary Structure and Securing and Supporting Devices .....	209
	25.3 Steel Securing and Supporting Devices Bearing Stress.....	209
	25.5 Tensile Stress on Threaded Bolts .....	209
27	Operating and Maintenance Manual.....	209
	27.1 Manual .....	209
	27.3 Operating Procedures .....	209
	FIGURE 1 Entry and Flare Angles .....	204
	FIGURE 2 Definition of $\alpha_m$ and $\beta_m$ .....	205
	FIGURE 3 Visor Type Bow Door.....	206

<b>SECTION 17</b>	<b>Bulwarks, Rails, Freeing Ports, Portlights, Ventilators, Tank Vents and Overflows .....</b>	<b>211</b>
1	Bulwarks and Guard Rails .....	211
1.1	Height on Manned Vessels .....	211
1.3	Strength of Bulwarks .....	211
1.5	Spacing of Guard Rails .....	211
3	Access and Crew Protection .....	212
3.1	General .....	212
3.3	Access to Bow on Tankers .....	212
5	Freeing Ports .....	215
5.1	Basic Area .....	215
5.3	Vessels with Less than Standard Sheer .....	215
5.5	Trunks .....	215
5.7	Open Superstructures .....	215
5.9	Details of Freeing Ports .....	216
7	Portlights .....	216
7.1	Application .....	216
7.3	Location .....	216
7.5	Construction .....	216
9	Ventilators, Tank Vents and Overflows .....	217
9.1	General .....	217
9.3	Ventilators .....	217
9.5	Tank Vents and Overflows .....	217
9.7	Ventilators, Tank Vents and Overflows on the Fore Deck .....	217
TABLE 1	Acceptable Arrangement for Access .....	213
TABLE 2	760 mm (30 in.) High Tank Vents and Overflows Thickness and Bracket Standards .....	219
TABLE 3	900 mm (35.4 in.) High Ventilator Thickness and Bracket Standards .....	220

<b>SECTION 18</b>	<b>Ceiling, Sparring and Protection of Steel .....</b>	<b>221</b>
1	Close Ceiling .....	221
3	Sparring .....	221
5	Protection of Steel Work .....	221
5.1	All Spaces .....	221
5.3	Salt Water Ballast Space .....	221
5.5	Oil Spaces .....	221
5.7	Cargo Holds on Bulk Carriers (including Combination Carriers) .....	222
FIGURE 1	Extent of Coatings .....	222



<b>SECTION 19 Weld Design.....</b>	<b>223</b>
1    Fillet Welds .....	223
1.1    General .....	223
3    Tee Connections .....	223
3.1    Size of Fillet Welds.....	223
3.3    Length and Arrangement of Fillet .....	224
3.5    Intermittent Welding at Intersection .....	224
3.7    Welding of Longitudinal to Plating .....	224
3.9    Stiffeners and Webs to Hatch Covers .....	224
3.11    Thin Plating .....	224
5    Tee-Type End Connections .....	229
7    Ends of Unbracketed Stiffeners .....	229
9    Reduced Weld Size .....	229
9.1    General .....	229
9.3    Controlled Gaps .....	229
9.5    Deep Penetration Welds .....	229
11    Lapped Joints.....	229
11.1    General .....	229
11.3    Overlapped End Connections .....	229
11.5    Overlapped Seams .....	230
13    Plug Welds or Slot Welds .....	230
15    Full or Partial Penetration Corner or Tee Joints .....	230
17    Alternatives .....	230
 TABLE 1    Weld Factors .....	 225

<b>APPENDIX 1 Calculation of Shear Stresses for Vessels Having Longitudinal Bulkheads .....</b>	<b>45</b>
1    Methods of Calculation .....	45
3    Calculation of the Shear Flow Around Closed Sections .....	45
5    Calculation of $m$ .....	46
7    Determination of $N_i$ .....	46

<b>APPENDIX 2 Loading Manuals and Loading Instruments .....</b>	<b>47</b>
1    General .....	47
1.1    Application .....	47
3    Definitions .....	47
3.1    Loading Guidance .....	47
3.3    Category I Vessels .....	48
3.5    Category II Vessels .....	48
5    Required Loading Guidance .....	48
5.1    Loading Manual.....	48
5.3    Loading Instrument .....	48
5.5    Modifications .....	48

7	Loading Manual .....	49
	7.1 Required Information .....	49
	7.3 Loading Conditions .....	49
	7.5 Language .....	49
9	Loading Instrument .....	49
	9.1 Type .....	49
	9.3 Required Verifications .....	49
	9.5 Language .....	50
11	Annual Surveys .....	50

TABLE 1	Loading Conditions in the Loading Manual .....	51
---------	------------------------------------------------	----

**APPENDIX 3 Loading Manuals and Loading Instruments: Additional Requirements for Bulk Carriers, Ore Carriers and Combination Carriers 150 meters (492 feet) and above in Length ( $L_f$ ) ..... 53**

1	General .....	53
	1.1 Application .....	53
	1.3 Definitions .....	53
3	Required Loading Guidance .....	53
	3.1 Loading Manual .....	53
	3.3 Loading Instrument .....	53
	3.5 Modifications .....	54
5	Loading Manual .....	54
	5.1 Required Information .....	54
	5.3 Loading Conditions .....	55
7	Loading Instrument .....	55
	7.1 Required Verifications .....	55

TABLE 1	Loading Conditions in the Loading Manual For Bulk Carriers, Ore Carriers and Combination Carriers 150 Meters (492 Feet) and above in Length ( $L_f$ ) .....	56
---------	-------------------------------------------------------------------------------------------------------------------------------------------------------------	----

TABLE 2	Guidance on Loading/Unloading Sequences .....	57
---------	-----------------------------------------------	----

**APPENDIX 4 Buckling Strength of Longitudinal Strength Members .... 59**

1	Application .....	59
3	Elastic Buckling Stresses .....	59
	3.1 Elastic Buckling of Plates .....	59
	3.3 Elastic Buckling of Longitudinals .....	60
5	Critical Buckling Stresses .....	63
	5.1 Compression .....	63
	5.3 Shear .....	63
7	Working Stress .....	64
	7.1 Longitudinal Compressive Stress .....	64
	7.3 Shear Stresses .....	64

9	Scantling Criteria.....	65
9.1	Buckling Stress .....	65
TABLE 1	Standard Deduction .....	62
TABLE 2	Number of Half Waves.....	63

**APPENDIX 5 Guidelines for Calculating Bending Moment and Shear Force in Rudders and Rudder Stocks ..... 173**

1	Application .....	173
3	Spade Rudders .....	173
3.1	Rudder .....	173
3.3	Lower Stock .....	174
3.5	Moment at Top of Upper Stock Taper .....	174
3.7	Bearing Reaction Forces.....	175
5	Rudders Supported by Shoe Piece .....	176
5.1	Shear Force, Bending Moment and Reaction Forces .....	176
7	Rudders Supported by a Horn with One Pintle.....	177
7.1	Shear Force, Bending Moment and Reaction Forces .....	177
FIGURE 1	Spade Rudder.....	175
FIGURE 2	Rudder Supported by Shoe Piece .....	177
FIGURE 3	Rudder Supported by a Horn with One Pintle.....	178

**APPENDIX 6 Portable Beams and Hatch Cover Stiffeners of Variable Cross Section ..... 195**

1	Application .....	195
FIGURE 1	$SM$ and $I$ of Construction Elements.....	196

This Page Intentionally Left Blank

PART

# 3

CHAPTER **2 Hull Structures and Arrangements**

SECTION **1 Longitudinal Strength**

## 1 Application

Vessels to be classed for unrestricted service, are to have longitudinal strength in accordance with the requirements of this section. Vessels, however, having one or more of the following characteristics will be subject to special consideration:

- i) Proportions:  $L/B < 5, B/D > 2.5$
- ii) Length:  $L > 500$  m (1640 ft)
- iii) Block Coefficient:  $C_b < 0.6$
- iv) Large deck opening
- v) Vessels with large flare
- vi) Carriage of heated cargoes
- vii) Unusual type or design

## 3 Longitudinal Hull Girder Strength

### 3.1 Sign Convention of Bending Moment and Shear Force

The sign convention for bending moment and shear force is shown in 3-2-1/Figure 1.

### 3.3 Still-water Bending Moment and Shear Force (1 July 2006)

#### 3.3.1 General (1 July 2006)

Still-water bending moment and shear force calculations, determining the bending moment and hull girder shear force values along the vessel's entire length, are to be submitted together with the distribution of lightship weights.

For bulk carriers with notation **BC-A, BC-B or BC-C** and length as defined in 3-1-1/3.1 of 150 m (492 ft) or more, see also 5-3-A6/5, 5-3-3/3.1 and Appendix 5-3-A5a for hold flooded conditions.

### 3.3.2 Design Cargo and Ballast Loading Conditions (1 July 2003)

The calculations are to consider the effect of bunker, fresh water and consumable stores at departure and arrival. Where their amount and disposition at any stage of the voyage are considered more severe, calculations for such intermediate conditions are to be submitted in addition to those for departure and arrival conditions.

Also, where any ballasting/deballasting is intended during a voyage, calculations for the intermediate condition just before and just after ballasting and/or deballasting any ballast tanks are to be submitted and, where approved, included in the loading manual for guidance.

### 3.3.3 Ballast Tanks in Ballast Loaded Conditions (1 July 2006)

Ballast loading conditions involving partially filled ballast tanks (peak tanks and/or other ballast tanks) are not permitted as design conditions unless:

- i) Design stress limits are satisfied for all filling levels between empty and full, and
- ii) For bulk carriers, the requirements in Appendix 5-3-A5a, as applicable, are complied with for all filling levels between empty and full.

For the purpose of compliance with the “all filling levels” requirement, calculations for full and empty conditions at each departure and arrival, and where required by 3-2-1/3.3.2, at any intermediate condition, may be accepted. **The tanks intended to be partially filled are assumed to be:**

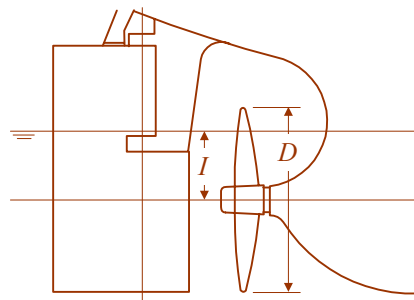
- Empty
- Full
- Partially filled at intended level

Where multiple tanks are intended to be partially filled, all combinations of empty, full or partially filled at intended level for those tanks are to be investigated.

However, for conventional ore carriers with large wing water ballast tanks in cargo area, where empty or full ballast water filling levels of one or maximum two pairs of these tanks lead to the vessel’s trim exceeding one of the following conditions, it is sufficient to demonstrate compliance with maximum, minimum and intended partial filling levels of these one or maximum two pairs of ballast tanks such that the ship’s condition does not exceed any of these trim limits. Filling levels of all other wing ballast tanks are to be considered between empty and full. The trim conditions mentioned above are:

- Trim by stern of 3% of the vessel’s length, or
- Trim by bow of 1.5% of the vessel’s length, or
- Any trim that can not maintain propeller immersion ( $I/D$ ) not less than 25%, where:

- $I$  = distance from propeller centerline to the waterline
- $D$  = propeller diameter



The maximum and minimum filling levels of the above mentioned pairs of side ballast tanks are to be indicated in the loading manual.

### 3.3.4 Ballast Tanks in Cargo Loaded Conditions (1 July 2003)

Cargo loading conditions involving partially filled peak tanks are not permitted as design conditions unless the conditions indicated in 3-2-1/3.3.3 for partially filled tanks are complied with.

### 3.3.5 Sequential Ballast Water Exchange (1 July 2006)

The requirements of 3-2-1/3.3.3 and 3-2-1/3.3.4 are not applicable to ballast water exchange using the sequential method.

## 3.5 Wave Loads

### 3.5.1 Wave Bending Moment Amidships

The wave bending moment, expressed in kN-m (tf-m, Ltf-ft) may be obtained from the following equations.

$$M_{ws} = -k_1 C_1 L^2 B (C_b + 0.7) \times 10^{-3} \quad \text{Sagging Moment}$$

$$M_{wh} = +k_2 C_1 L^2 B C_b \times 10^{-3} \quad \text{Hogging Moment}$$

where

$$k_1 = 110 \text{ (11.22, 1.026)}$$

$$k_2 = 190 \text{ (19.37, 1.772)}$$

$$C_1 = 10.75 - \left( \frac{300 - L}{100} \right)^{1.5} \quad 90 \leq L \leq 300 \text{ m}$$

$$= 10.75 \quad 300 < L \leq 350 \text{ m}$$

$$= 10.75 - \left( \frac{L - 350}{150} \right)^{1.5} \quad 350 \leq L \leq 500 \text{ m}$$

$$C_1 = 10.75 - \left( \frac{984 - L}{328} \right)^{1.5} \quad 295 \leq L \leq 984 \text{ ft}$$

$$= 10.75 \quad 984 < L < 1148 \text{ ft}$$

$$= 10.75 - \left( \frac{L - 1148}{492} \right)^{1.5} \quad 1148 \leq L \leq 1640 \text{ ft}$$

$$L = \text{length of vessel, as defined in 3-1-1/3.1, in m (ft)}$$

$$B = \text{breadth of vessel, as defined in 3-1-1/5, in m (ft)}$$

$$C_b = \text{block coefficient, as defined in 3-1-1/11.3, but is not to be taken less than 0.6}$$

### 3.5.2 Envelope Curve of Wave Bending Moment

The wave bending moment along the length,  $L$ , of the vessel may be obtained by multiplying the midship value by the distribution factor  $M$ , given by 3-2-1/Figure 2.

### 3.5.3 Wave Shear Force

The envelopes of maximum shearing forces induced by waves,  $F_w$ , as shown in 3-2-1/Figure 3 and 3-2-1/Figure 4, may be obtained from the following equations.

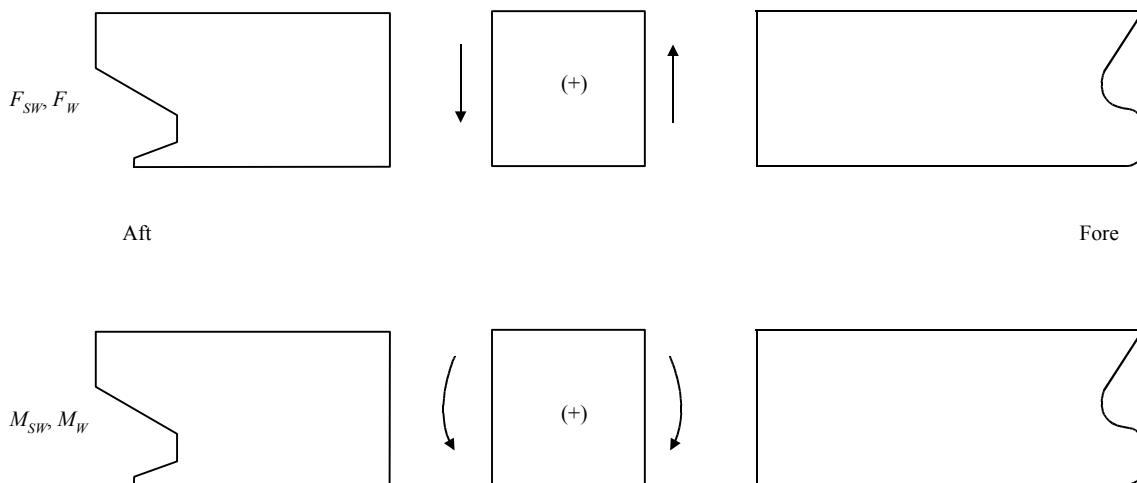
$$F_{wp} = +kF_1C_1LB(C_b + 0.7) \times 10^{-2} \quad \text{For positive shear force}$$

$$F_{wn} = -kF_2C_1LB(C_b + 0.7) \times 10^{-2} \quad \text{For negative shear force}$$

where

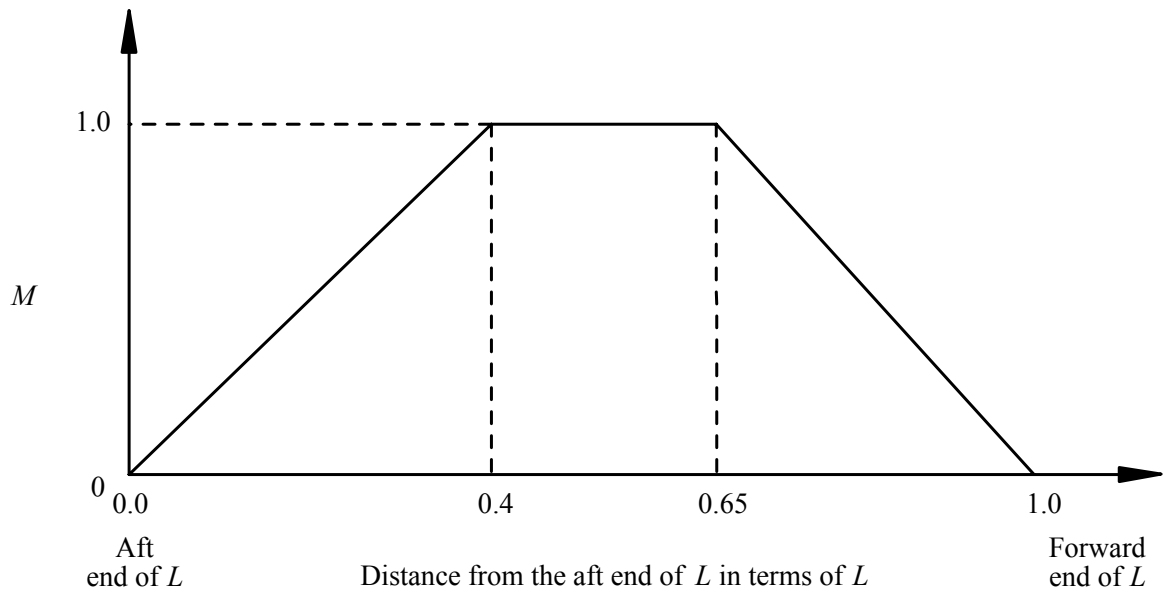
- $F_{wp}, F_{wn}$  = maximum shearing force induced by wave, in kN (tf, Ltf)
- $C_1$  = as defined in 3-2-1/3.5.1
- $L$  = length of vessel, as defined in 3-1-1/3.1, in m (ft)
- $B$  = breadth of vessel, as defined in 3-1-1/5, in m (ft)
- $C_b$  = block coefficient, as defined in 3-1-1/11.3, but not to be taken less than 0.6
- $k$  = 30 (3.059, 0.2797)
- $F_1$  = distribution factor, as shown in 3-2-1/Figure 3
- $F_2$  = distribution factor, as shown in 3-2-1/Figure 4

**FIGURE 1**  
**Sign Convention**

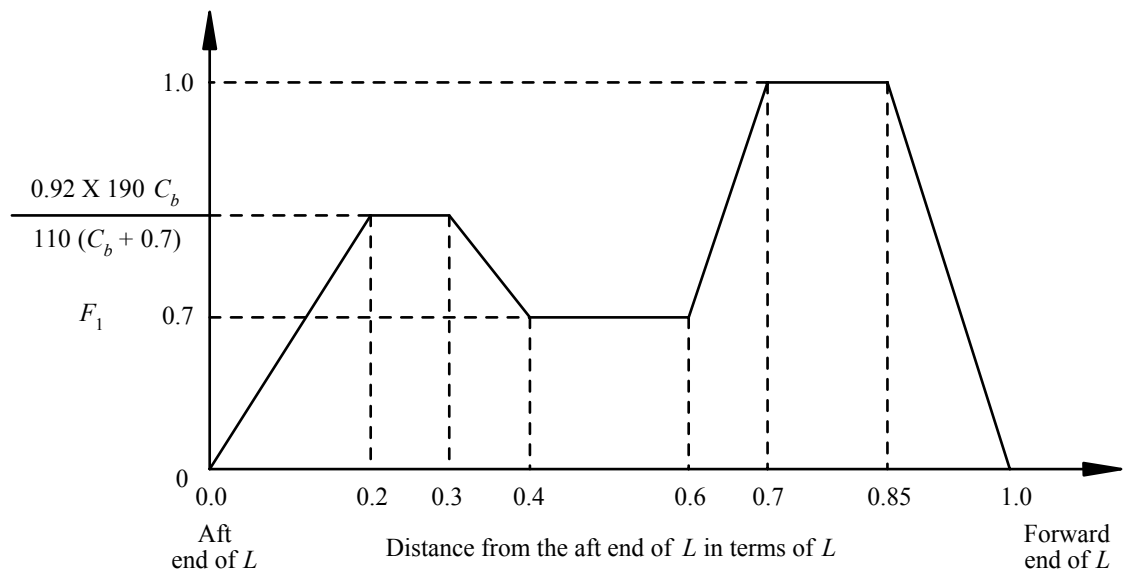




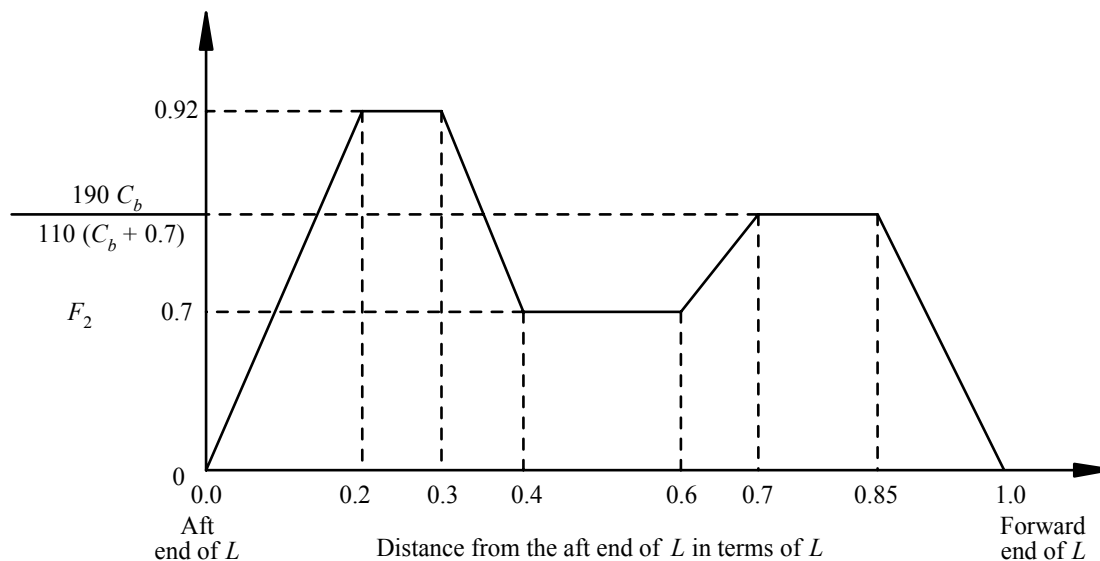
**FIGURE 2**  
**Distribution Factor  $M$**



**FIGURE 3**  
**Distribution Factor  $F_1$**



**FIGURE 4**  
**Distribution Factor  $F_2$**



### 3.7 Bending Strength Standard

#### 3.7.1 Hull Girder Section Modulus

3.7.1(a) *Section Modulus.* The required hull girder section modulus for  $0.4L$  amidships is to be the greater of the values obtained from the following equation or 3-2-1/3.7.1(b):

$$SM = M_t / f_p \text{ cm}^2\text{-m (in}^2\text{-ft)}$$

where

$M_t$  = total bending moment, as obtained below

$f_p$  = nominal permissible bending stress

= 17.5 kN/cm<sup>2</sup> (1.784 tf/cm<sup>2</sup>, 11.33 Ltf/in<sup>2</sup>)

The total bending moment,  $M_t$ , is to be considered as the maximum algebraic sum (see sign convention in 3-2-1/3.1) of still-water bending moment and wave-induced bending moment, as follows:

$$M_t = M_{sw} + M_w$$

where

$M_{sw}$  = still-water bending moment in accordance with 3-2-1/3.3, in kN-m (tf-m, Ltf-ft).

$M_w$  = maximum wave-induced bending moment in accordance with 3-2-1/3.5.1

3.7.1(b) *Minimum Section Modulus.* The minimum hull girder section modulus amidships is not to be less than obtained from the following equation:

$$SM = C_1 C_2 L^2 B (C_b + 0.7) \quad \text{cm}^2\text{-m (in}^2\text{-ft)}$$

where

- $C_1$  = as defined in 3-2-1/3.5
- $C_2$  = 0.01 (0.01,  $1.44 \times 10^{-4}$ )
- $L$  = length of vessel, as defined in 3-1-1/3.1, in m (ft)
- $B$  = breadth of vessel, as defined in 3-1-1/5, in m (ft)
- $C_b$  = block coefficient, as defined in 3-1-1/11.3, but is not to be taken less than 0.6

3.7.1(c) *Extension of Midship Section Modulus.* In general, where the still-water bending moment envelope curve is not submitted or where 3-2-1/3.7.1(b) governs, scantlings of all continuous longitudinal members of the hull girder are to be maintained throughout  $0.4L$  amidships and then may be gradually tapered beyond.

Where the scantlings are based on the still-water bending moment envelope curves, items included in the hull girder section modulus amidships are to be extended as necessary to meet the hull girder section modulus required at the location being considered.

### 3.7.2 Hull Girder Moment of Inertia

The hull girder moment of inertia,  $I$ , amidships, is to be not less than:

$$I = L \cdot SM / 33.3 \quad \text{cm}^2\text{-m}^2 \text{ (in}^2\text{-ft}^2)$$

where

- $L$  = length of vessel, as defined in 3-1-1/3.1, in m (ft)
- $SM$  = required hull girder section modulus, in  $\text{cm}^2\text{-m (in}^2\text{-ft)}$ . See 3-2-1/3.7.1.

## 3.9 Shearing Strength

### 3.9.1 General

In calculating the nominal total shear stress,  $f_s$ , due to still-water and wave-induced loads, the maximum algebraic sum of the shearing force in still-water  $F_{sw}$  and that induced by wave  $F_w$  at the station examined is to be used. The thickness of the side shell, and where fitted, the longitudinal bulkhead, is to be such that the nominal total shear stress  $f_s$ , as obtained from 3-2-1/3.9.2 or 3-2-1/3.9.4, are not greater than  $11.0 \text{ kN/cm}^2$  ( $1.122 \text{ tf/cm}^2$ ,  $7.122 \text{ Ltf/in}^2$ ).

### 3.9.2 Shearing Strength for Vessels without Effective Longitudinal Bulkheads

For vessels without continuous longitudinal bulkheads, the nominal total shear stress  $f_s$  in the side shell plating may be obtained from the following equation:

$$f_s = (F_{sw} + F_w) m / 2t_s I$$

where

- $I$  = moment of inertia of the hull girder at the section under consideration, in  $\text{cm}^4$  ( $\text{in}^4$ )
- $m$  = first moment, in  $\text{cm}^3$  ( $\text{in}^3$ ), about the neutral axis, of the area of the effective longitudinal material between the horizontal level at which the shear stress is being determined and the vertical extremity of effective longitudinal material, taken at the section under consideration.

$t_s$  = thickness of the side shell plating at the position under consideration, in cm (in.)

$F_{sw}$  = hull girder shearing force in still-water, in kN (tf, Ltf)

$F_w$  =  $F_{wp}$  or  $F_{wmp}$ , as specified by 3-2-1/3.5.3, in kN (tf, Ltf), depending upon loading.

### 3.9.3 Modification of Hull girder Shearing Force Peaks (1997)

The hull girder shearing force in still water,  $F_{sw}$ , to be used for calculating shear stresses in the side shell plating may be modified to account for the loads transmitted through the double bottom structure to the side shell through the transverse bulkhead. For this modification, unless a detailed calculation is performed, the following equation may be used as guidance to determine the shear force carried by the side shell at the transverse bulkhead (see 3-2-1/Figure 5), provided that the girders in the double bottom are arranged in accordance with 5-3-4/7.1.1 or 5-4-2/9.1, as appropriate.

$$F_s = F_{sw} - F_B \quad \text{kN (tf, Ltf)}$$

where

$F_{sw}$  = hull girder shearing force in still water as obtained by the conventional direct integration method, in kN (tf, Ltf).

$F_B$  =  $F_{BA}$  or  $F_{BF}$ , whichever is the lesser

$F_{BA}$  =  $(0.45 - 0.2\ell_A/b_A)W_A b_A/B$

$F_{BF}$  =  $(0.45 - 0.2\ell_F/b_F)W_F b_F/B$

$W_A, W_F$  = total load (net weight or net buoyancy) in the hold immediately abaft or forward of the bulkhead in question, in kN (tf, Ltf)

$\ell_A, \ell_F$  = length of the adjacent holds, respectively, containing  $W_A$  and  $W_F$ , in m (ft)

$b_A, b_F$  = breadth of the double bottom structure in the holds immediately abaft and forward of the bulkhead in question, respectively, in m (ft). For vessels having lower wing tanks with sloping tops, making an angle of about 45 degrees with the horizontal, the breadth may be measured between the midpoints of the sloping plating. For vessels having double skins with flat inner bottom, it may be measured to the inner skins.

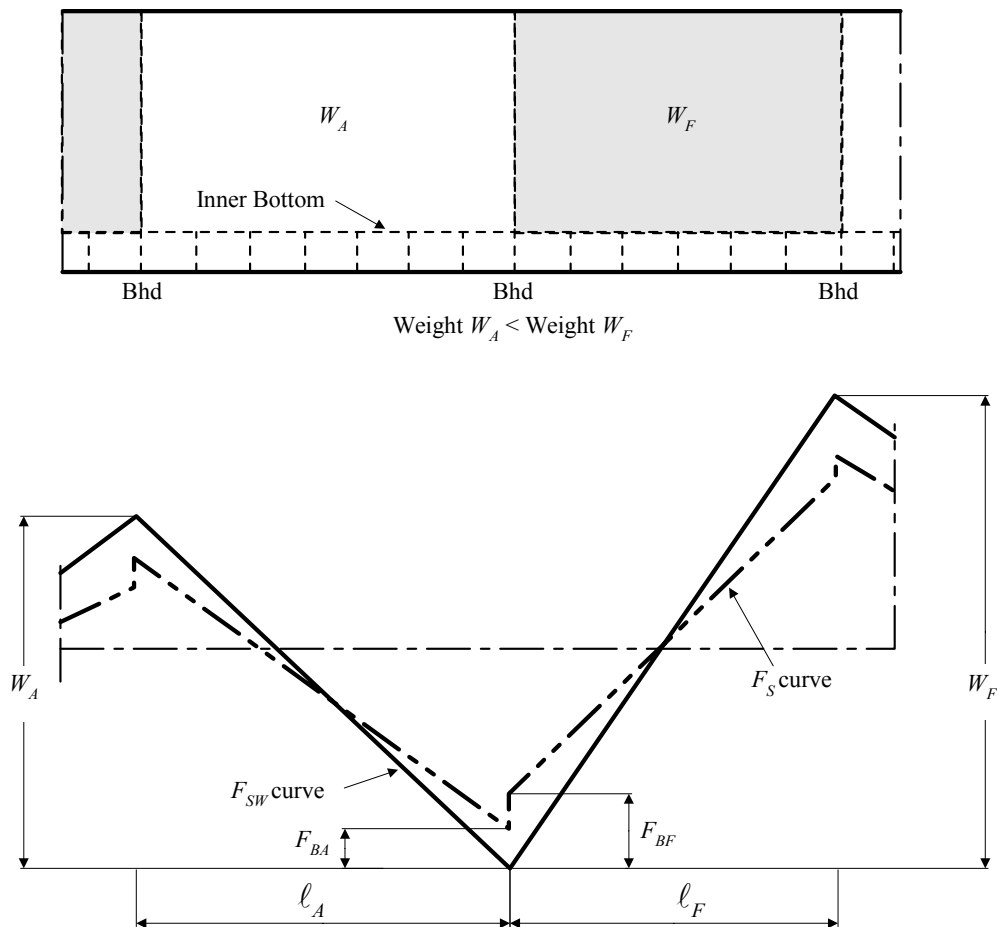
$B$  = breadth of vessel, as defined in 3-1-1/5, in m (ft)

### 3.9.4 Shearing Strength for Vessels with Two or Three Longitudinal Bulkheads

For vessels having continuous longitudinal bulkheads, the total shear stresses in the side shell and the longitudinal bulkheads are to be calculated by an acceptable method. In determining the still-water shear force, consideration is to be given to the effects of non-uniform athwartship distribution of loads. The method described in Appendix 3-2-A1 may be used as a guide in calculating the nominal total shear stress  $f_s$  related to the shear flow in the side shell or longitudinal bulkhead plating.

Alternative methods of calculation will also be considered. Some acceptable methods are shown in 5-1-4/5 and Appendix 5-2-A1.

**FIGURE 5**  
**Shear Force Distribution (1997)**



## 5 Longitudinal Strength with Higher-Strength Materials

### 5.1 General

Vessels where the effective longitudinal material of either the upper or lower flanges of the main hull girder, or both, are constructed of materials having mechanical properties greater than those of ordinary-strength hull structural steel (see Section 2-1-2), are to have longitudinal strength generally in accordance with the preceding paragraphs of this section, but the value of the hull girder section modulus and permissible shear stress may be modified as permitted by 3-2-1/5.5 and 3-2-1/5.7. Application of higher-strength material is to be continuous over the length of the vessel to locations where the stress levels will be suitable for the adjacent mild-steel structure. Higher-strength steel is to be extended to suitable locations below the strength deck and above the bottom, so that the stress levels will be satisfactory for the remaining mild steel structure. Longitudinal framing members are to be continuous throughout the required extent of higher-strength steel.

### 5.3 Hull Girder Moment of Inertia

The hull girder moment of inertia is to be not less than required by 3-2-1/3.7.2.

### 5.5 Hull Girder Section Modulus

When either the top or bottom flange of the hull girder, or both, is constructed of higher-strength material, the section modulus, as obtained from 3-2-1/3.7, may be reduced by the factor  $Q$ .

$$SM_{hts} = Q (SM)$$

where

$SM$  = section modulus as obtained from 3-2-1/3.7

$Q$  = 0.78 for H32 strength steel

$Q$  = 0.72 for H36 strength steel

H32, H36 = as specified in Section 2-1-3.

$Q$  factor for steels having other yield points or yield strengths will be specially considered.

### 5.7 Hull girder Shearing Force

Where the side shell or longitudinal bulkhead is constructed of higher strength material, the permissible shear stresses indicated in 3-2-1/3.9 may be increased by the factor  $1/Q$ . For plate panel stability, see 3-2-1/19.

## 7 Loading Guidance

### 7.1 Loading Manual and Loading Instrument (1 July 1998)

All vessels contracted for construction on or after 1 July 1998, are to be provided with a loading manual and, where required, a loading instrument in accordance with Appendix 3-2-A2.

In addition, bulk carriers, ore carriers and combination carriers 150 m (492 ft) or more in length ( $L_f$ ), are to comply with the requirements in Appendix 3-2-A3.

### 7.3 Allowable Stresses (1 July 1998)

#### 7.3.1 At Sea

See 3-2-1/3.7.1 for bending stress and 3-2-1/3.9.1 for shear stress for vessels with ordinary strength steel material. For higher-strength steel, the allowable stress may be increased by a factor of  $1/Q$  where  $Q$  is as defined in 3-2-1/5.5.

#### 7.3.2 In Port

The allowable still water in-port stress is 13.13 kN/cm<sup>2</sup> (1.34 tf/cm<sup>2</sup>, 8.5 Ltf/in<sup>2</sup>) for bending and 10 kN/cm<sup>2</sup> (1.025 tf/cm<sup>2</sup>, 6.5 Ltf/in<sup>2</sup>) for shear. For higher-strength steel, the allowable stress may be increased by a factor of  $1/Q$  where  $Q$  is as defined in 3-2-1/5.5.

## 9 Section Modulus Calculation

### 9.1 Items Included in the Calculation

In general, the following items may be included in the calculation of the hull girder section modulus, provided that they are continuous or effectively developed:

- Deck plating (strength deck and other effective decks)
- Shell and inner bottom plating
- Deck and bottom girders
- Plating and longitudinal stiffeners of longitudinal bulkheads
- All longitudinals of deck, side, bottom and inner bottom
- Continuous longitudinal hatch coamings. See 3-2-1/13.

### 9.3 Effective Areas Included in the Calculation

In general, all openings are to be deducted from the sectional areas of longitudinal strength members to be used in the hull girder section modulus calculation, except that small isolated openings need not be deducted, provided that these openings and the shadow area breadths of other openings in any one transverse section do not reduce the hull girder section modulus by more than 3%. The breadth or depth of such openings is not to be greater than 1200 mm (47 in.) or 25% of the breadth or depth of the member in which it is located, whichever is less, with a maximum of 75 mm (3 in.) for scallops. The length of small isolated openings, which are not required to be deducted, is generally not to be greater than 2500 mm (100 in.). The shadow area of an opening is the area forward and aft of the opening enclosed by lines drawn tangential to the corners of the opening and intersecting each other to form an included angle of 30 degrees. See 3-2-1/Figure 6.

### 9.5 Section Modulus to the Deck or Bottom

The section modulus to the deck, or bottom, is obtained by dividing the moment of inertia  $I$  by the distance from the neutral axis to the molded deck line at side or to the base line, respectively.

### 9.7 Section Modulus to the Top of Hatch Coamings

For continuous longitudinal hatch coamings, in accordance with 3-2-1/13, the section modulus to the top of the coaming is to be obtained by dividing the moment of inertia  $I$  by the distance from the neutral axis to the deck at side plus the coaming height. This distance need not exceed  $y_t$  as given by the following equation, provided that  $y_t$  is not less than the distance to the molded deck line at side.

$$y_t = y(0.9 + 0.2x/B) \quad \text{m (ft)}$$

where

$y$  = distance, in m (ft), from the neutral axis to the top of the continuous coaming.

$x$  = distance, in m (ft), at the top of the hatch coaming from the outboard edge of the continuous coaming web plate to the centerline of the vessel

$B$  = breadth of vessel, as defined in 3-1-1/5, in m (ft)

$x$  and  $y$  are to be measured to the point giving the largest value of  $y_t$

Section modulus to the top of longitudinal hatch coamings between multi-hatchways will be subject to special considerations.

## 11 Strength Decks

### 11.1 Definition

The uppermost deck to which the side shell plating extends is to be considered the strength deck for that portion of the length, except in way of short superstructures, wherein the modified requirements for the side shell (see 3-2-2/3) and superstructure deck (see 3-2-11/1.3) are adopted. In way of such superstructures, the deck on which the superstructures are located is to be considered the strength deck.

### 11.3 Tapering of Deck Sectional Areas

In general, the tapering of deck sectional areas beyond the amidship  $0.4L$  is to be in accordance with 3-2-1/3.7.1(c). The deck sectional area at  $0.15L$  from the ends may be one-half of the amidships deck area. In way of a superstructure beyond the amidship  $0.4L$ , the strength deck area may be reduced to approximately 70% of the deck area required at that location if there were no superstructure.

## 13 Continuous Longitudinal Hatch Coamings and Above Deck Girders

Where strength deck longitudinal hatch coamings of length greater than  $0.14L$  are effectively supported under by longitudinal bulkheads or deep longitudinal girders, the coamings are to be longitudinally stiffened in accordance with 3-2-15/5.9. The hull girder section modulus amidships to the top of the coamings is to be as required by 3-2-1/3.7.1, 3-2-1/3.7.2 and 3-2-1/9.7, but the section modulus to the deck at side, excluding the coamings, need not be determined in way of such coamings.

Continuous longitudinal girders on top of the strength deck are to be considered similarly. Their scantlings are also to be in accordance with Section 3-2-8.

## 15 Effective Lower Decks

To be considered effective, and in order to be included in calculating the hull girder section modulus, the thickness of the stringer plate and the deck plating is to comply with the requirements of 3-2-3/5. The sectional areas of lower decks used in calculating the section modulus are to be obtained as described in 3-2-1/9.3, but should exclude the cutout in the stringer plate in way of through frames. In general, where the still-water bending moment envelope curve is not submitted, or where 3-2-1/3.7.1(b) governs, these areas are to be maintained throughout the midship  $0.4L$  and may be gradually reduced to one-half their midship value at  $0.15L$  from the ends. Where bending moment envelope curves are used, the deck sectional areas are to be adequate to meet the hull girder section modulus requirements at the location being considered.

## 17 Longitudinal Deck Structures Inboard of Lines of Openings

### 17.1 General

Where deck structures are arranged with two or more large openings abreast, the degree of effectiveness of that portion of the longitudinal structure located between the openings is to be determined in accordance with the following:

Plating and stiffening members forming these structures may be included in the hull girder section modulus calculation, provided they are substantially constructed, well supported both vertically and laterally, and developed at their ends to be effectively continuous with other longitudinal structure located forward and abaft that point.



### 17.3 Effectiveness

The plating and longitudinal stiffening members of longitudinal deck structures complying with the basic requirements of the foregoing paragraph, supported by longitudinal bulkheads, in which the transverse slenderness ratio  $\ell/r$  is not greater than 60, may be considered as fully effective in the hull girder section modulus. Longitudinal deck structures, not supported by longitudinal bulkheads, but of substantial construction having a slenderness ratio  $\ell/r$  about any axis not greater than 60, based on the span between transverse bulkheads, or other major supports, may be considered as partially effective. The effective area, obtained as the product of the net sectional area of the longitudinal deck structure inboard of lines of hatch openings and the factor  $H_o$ , as given below, may be used in the hull girder section modulus calculations.

$$H_o = \frac{0.62}{1 + 0.38 \left( \frac{A_o}{A} + \frac{Z^2 A_o}{I} \right)}$$

where

- $A$  = cross sectional area of hull girder amidships, port and starboard, excluding longitudinal deck structures inside the lines of outermost hatch openings, in  $\text{cm}^2$  ( $\text{in}^2$ )
- $I$  = moment of inertia of hull girder amidships, port and starboard, about the horizontal neutral axis, excluding longitudinal deck structures inside the lines of outermost hatch openings, in  $\text{cm}^2\text{-m}^2$  ( $\text{in}^2\text{-ft}^2$ )
- $Z$  = distance between the horizontal neutral axis of area  $A$ , and the centroid of area  $A_o$ , in m (ft)
- $A_o$  = total cross sectional area of the longitudinal deck structures inside the lines of outermost hatch openings, including plating, longitudinal stiffeners, and girders, port and starboard, in  $\text{cm}^2$  ( $\text{in}^2$ )

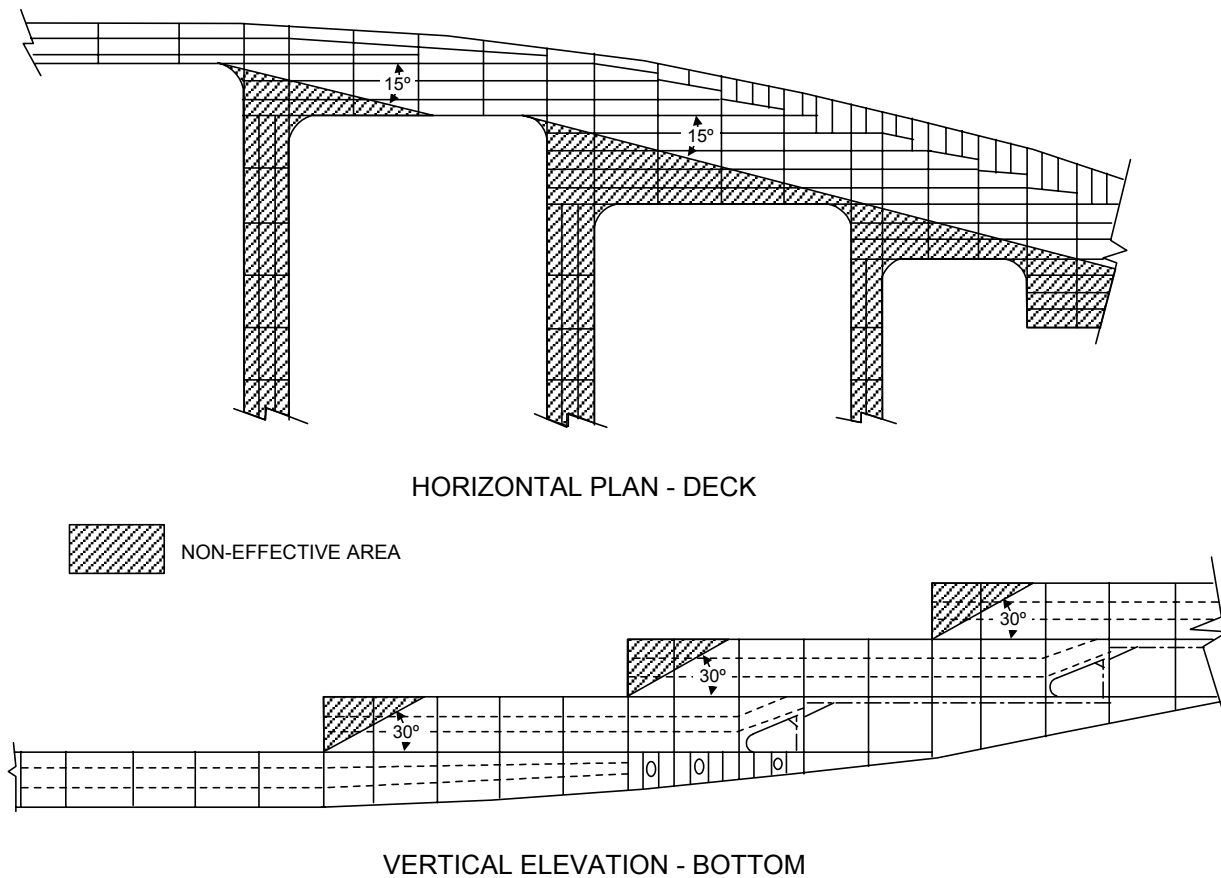
An efficiency factor obtained by other methods of engineering analysis will be subject to special consideration.

## 19 Buckling Strength (1995)

Where the various strength members are subjected to compressive or shear stresses due to longitudinal bending, the stability of the local plate panels and the supporting members is to be checked against buckling. Calculations, in accordance with Appendix 3-2-A4, are to be submitted for review.

Where still water bending moments are positive (hogging) in all operating conditions, the total bending moment,  $M_t$ , is to be taken as not less than  $0.9M_{ws}$  for the purpose of evaluating the structural stability of the hull girder upper flange. Where it can be shown that all possible conditions of loading between lightship and full load draft result in positive (hogging) still water bending moments, such as with passenger vessels, the above specified minimum total bending moment may be specially considered. A statistical analysis of wave induced bending moment is to be carried out in such instances, taking into account the effect of the hull form including bow flare.

**FIGURE 6**  
**Effective Area of Hull Girder Members**



CHAPTER **2 Hull Structures and Arrangements**APPENDIX **1 Calculation of Shear Stresses for Vessels Having Longitudinal Bulkheads****1 Methods of Calculation**

The nominal total shear stress  $f_s$  in the side shell or longitudinal bulkhead plating is related to the shear flow  $N$  at that point, by the following equation:

$$\begin{aligned} f_s &= N/t, \quad \text{kN/cm}^2 \text{ (tf/cm}^2, \text{ Ltf/in}^2\text{)} \\ N &= \text{shear flow, kN/cm (tf/cm, Ltf/in)} \\ t &= \text{thickness of the plating, cm (in.)} \end{aligned}$$

**3 Calculation of the Shear Flow Around Closed Sections**

The shear flow of a closed and prismatic structure is expressed by the following equation.

$$\begin{aligned} N &= (F m/I) + N_i, \quad \text{kN/cm (tf/cm, Ltf/in)} \\ F &= \text{total shear force at the section under consideration, in kN (tf, Ltf)} \\ m &= \text{first moment about the neutral axis of the section, in cm}^3 \text{ (in}^3\text{), of the area of the longitudinal material between the zero shear level and the vertical level, at which the shear stress is being calculated} \\ m &= \int_0^p Z t ds + \sum_{i=0}^n a_i z_i \quad \text{cm}^3 \text{ (in}^3\text{)} \\ I &= \text{moment of inertia of the section, in cm}^4 \text{ (in}^4\text{)} \\ N_i &= \text{constant shear flow around the cell regarded as an integration constant of unknown value arising from substituting the statically indeterminate structure by statically determinate one, in kN/cm (tf/cm, Ltf/in)} \\ Z &= \text{distance from section neutral axis to a point in the girth, positive downward, in cm (in.)} \\ a &= \text{equivalent sectional area of the stiffener or girder attached to the deck, shell and bulkhead plating, in cm}^2 \text{ (in}^2\text{)} \\ s &= \text{length along girth and longitudinal bulkhead, in cm (in.)} \end{aligned}$$

## 5 Calculation of $m$

To calculate the value of  $m$  requires the knowledge or assumption of a zero shear point in the closed cell. As an example, in the case of a simplified tanker section, the deck point at the centerline is a known point of zero shear in the absence of the centerline girder. An arbitrary point may be chosen in the wing tank cell. Superposition of the constant  $N_i$  to the shear flow resulting from the assumption of zero shear point will yield to the correct shear flow around the wing cell.

## 7 Determination of $N_i$

$N_i$  is determined by using Bredt's torsion formula, making use of the assumption that there is no twist in the cell section, i.e., the twist moment resulting from the shear flow around a closed cell should equal zero, or  $\oint N \frac{ds}{t} = 0$ . In a multicell structure of  $n$  number of cells, the formula can be written for the  $i^{\text{th}}$  cell as follows.

$$\oint N_i \frac{ds}{t} = \frac{F}{I} \oint m_i \frac{ds}{t} + N_{i-1} \int_{Div} \frac{ds}{t} + N_i \oint \frac{ds}{t} + N_{i+1} \int_{Div} \frac{ds}{t} = 0$$

$Div =$  common division between cell  $i$  and the adjacent cells  $i - 1$  and  $i + 1$ .

The first term represents twist moment around cell  $i$  at the assumed statically determined status. The  $m$  values are calculated upon arbitrary zero shear points in the cell  $i$  and the adjacent cells. The remaining terms in the equations represent the balancing twist moments around cell  $i$  and of those carried out by the common divisions in the adjacent cells  $i - 1$  and  $i + 1$ .

To determine the constant shear flow in the cells  $N_1, N_2, \dots, N_i, N_n$ ,  $n$  number of similar equations are formed for each cell and are solved simultaneously.

PART

# 3

CHAPTER **2 Hull Structures and Arrangements**

APPENDIX **2 Loading Manuals and Loading Instruments (1 July 1998)**

*Note:* These requirements are intended to satisfy Regulation 10(1) of the International Convention on Load Lines, 1966.

## 1 General

### 1.1 Application

The requirements in [this Appendix](#) apply to all classed cargo vessels that are contracted for construction on or after 1 July 1998.

For bulk carriers, ore carriers and combination carriers having a freeboard length ( $L_f$ ), as defined in 3-1-1/3.3, of 150 m (492 ft) and above, additional requirements in Appendix 3-2-A3 will also apply.

## 3 Definitions

### 3.1 Loading Guidance

Loading guidance is a generic term covering both loading manual and loading instrument, as defined below.

#### 3.1.1 Loading Manual

A loading manual is a document containing sufficient information to enable the master of the vessel to arrange for the loading and ballasting of the vessel in such a way as to avoid the creation of any unacceptable stresses in the vessel's structure.

#### 3.1.2 Loading Instrument

A loading instrument is an instrument by means of which it can be easily and quickly ascertained that the still-water bending moments, shear forces, and, where applicable, the still-water torsional moments and lateral loads at specified points along the length of the vessel will not exceed the specified values in any load or ballast condition.

### 3.3 Category I Vessels

Category I vessels are **any** of the following:

#### 3.3.1

Vessels, such as container carriers, with large deck openings where combined stresses due to vertical and horizontal hull girder bending, torsional and lateral loads need be considered

#### 3.3.2

Vessels, such as bulk carriers, ore carriers and combination carriers, designed for non-homogeneous loading, where the cargo and/or ballast may be unevenly distributed, except those belonging to 3-2-A2/3.5.3.

#### 3.3.3

Tank vessels, such as oil carrier and fuel carriers, except those belonging to 3-2-A2/3.5.3.

#### 3.3.4

Chemical carriers and gas carriers

### 3.5 Category II Vessels

Category II vessels are **any** of the following:

#### 3.5.1

Vessels, such as passenger vessels and others, with such arrangements that would allow only a small possibility for variation in the distribution of cargo and ballast

#### 3.5.2

Vessels, such as ro-ro ferries, on regular and fixed trading patterns where the loading manual gives sufficient guidance

#### 3.5.3

Vessels less than 120 m (394 ft) in length,  $L$ , when their design takes into account the uneven distribution of cargo or ballast.

## 5 Required Loading Guidance

### 5.1 Loading Manual

All vessels are to be provided with a loading manual reviewed and stamped by ABS in accordance with 3-2-A2/7.

### 5.3 Loading Instrument (2003)

In addition to the loading manual, vessels of Category 1 of 100 m (328 ft) or more in length are to be provided with a loading instrument verified in accordance with 3-2-A2/9.

### 5.5 Modifications

Where modifications to the vessel or to the loading/trading pattern result in changes to the input information, a revised or new loading manual is to be submitted and a stamped copy is to be placed aboard the vessel to replace the existing manual. The loading instrument is to be verified in accordance with 3-2-A2/9.3 or newly installed and verified in such cases.

Where changes due to modification of the vessel are such that the still water bending moments and shear forces corresponding to the new loading conditions are within  $\pm 2\%$  of the existing allowable values, the existing allowable values need not be modified.

## 7 Loading Manual

### 7.1 Required Information

The loading manual is to be based on the final data of the vessel and is to include at least the following information:

- i)* The loading conditions upon which the design of this vessel is approved.
- ii)* The results of the calculations of still water bending moments and shear forces.
- iii)* Permissible limits of still water bending moments and shear forces and, where applicable, limitations due to torsional and lateral loads.
- iv)* Maximum allowable local double bottom loading.
- v)* If cargoes other than bulk cargoes are contemplated, such cargoes are to be listed together with any specific instructions for loading.
- vi)* Maximum allowable load on deck and hatch covers. If the vessel is not approved to carry load on deck or hatch covers, that fact is to be clearly stated in the loading manual.

### 7.3 Loading Conditions

The above information is to be based on the intended service conditions. See 3-2-A2/Table 1 for the selection of loading conditions.

### 7.5 Language

The loading manual is to be prepared in, or is to include, a language understood by the user. English may be considered to be a language understood by the user.

## 9 Loading Instrument

### 9.1 Type

A loading instrument is to be digital. A single point loading instrument is not acceptable.

### 9.3 Required Verifications

Before a loading instrument is accepted for the vessel, all relevant aspects of the instrument, including but not limited to, the following, are to be demonstrated to the Surveyor for his/her personal verification:

- That the instrument is type approved, where applicable
- That the instrument is based on the final data of the vessel
- That the number and position of read-out points are satisfactory
- That the relevant limits for all read-out points are satisfactory
- That the operation of the instrument after installation onboard, in accordance with the approved test conditions has been found satisfactory
- That approved test conditions are available onboard
- That an operational manual, which does not require approval, is available onboard for the instrument

## 9.5 Language

The operation manual and the instrument output are to be prepared in, or are to include, a language understood by the user. English may be considered to be a language understood by the user.

## 11 Annual Surveys

The requirements in 7-3-2/1.1.5 are to be complied with as follows:

At each Annual Survey, it is to be verified that the loading manual is onboard and, where applicable, a loading instrument is to be verified in working order. The operation manual for the loading instrument is also to be verified as being onboard.



**TABLE 1**  
**Loading Conditions in the Loading Manual**

1.	The loading manual is to include at least
1.1	full load conditions, for both departure and arrival conditions,
1.2	ballast conditions, for both departure and arrival conditions (see also 1.5)
1.3	any other critical loading conditions on which the design of the vessel is based.
1.4	in-port conditions (see also 1.5.3)
1.5	Intermediate conditions, including but not limited to
1.5.1	before and after any ballasting/deballasting during the voyage.
1.5.2	ballast exchange and its sequence, where intended,
1.5.3	during loading/unloading (for vessels in 2.1, 2.2 where applicable, and 2.5)
2.	The following conditions are to be considered for the particular type of vessel. The list does not preclude any loading conditions that are necessary for the particular service intended:
2.1	Oil Carriers:
2.1.1	homogeneous cargo if consistent with the service of the vessel
2.1.2	cargoes of typical densities within the expected range
2.1.3	part loaded conditions
2.1.4	short voyages (e.g. half bunker)
2.1.5	tank cleaning conditions
2.1.6	docking conditions afloat
2.2	Bulk Carriers, Ore Carriers, Container Carriers, Dry Cargo Vessels, Other Specialized Carriers:
2.2.1	homogeneous cargo if consistent with the service of the vessel
2.2.2	cargoes of typical densities within the expected range
2.2.3	heavy cargo with empty holds or non-homogeneous conditions
2.2.4	short voyages (e.g. half bunker)
2.2.5	deck cargoes
2.2.6	docking conditions afloat
2.3	Liquefied Gas Carriers:
2.3.1	homogeneous loading for all approved cargoes
2.3.2	with empty or partially filled tank(s)
2.3.3	docking conditions afloat
2.4	Chemical Carriers:
2.4.1	conditions for oil carriers
2.4.2	all approved high density cargoes
2.5	Combination Carriers
2.5.1	conditions as specified in 2.1 and 2.2 above.

This Page Intentionally Left Blank

PART

# 3

CHAPTER **2 Hull Structures and Arrangements**

APPENDIX **3 Loading Manuals and Loading Instruments: Additional Requirements for Bulk Carriers, Ore Carriers and Combination Carriers 150 meters (492 feet) and above in Length ( $L_f$ ) (1 July 1998)**

## **1 General**

### **1.1 Application**

The requirements in this Appendix apply to bulk carriers, ore carriers and combination carriers having a freeboard length ( $L_f$ ), as defined in 3-1-1/3.3, of 150 m (492 ft) and above. Unless otherwise stated, these requirements are additional to those in Appendix 3-2-A2.

### **1.3 Definitions**

For the purpose of this Appendix, the definitions in 3-2-A2/3 will apply.

## **3 Required Loading Guidance**

### **3.1 Loading Manual**

All vessels are to be provided with a Loading Manual, reviewed and stamped by ABS in accordance with 3-2-A3/5.

### **3.3 Loading Instrument**

In addition to the loading manual, all vessels of Category I are to be provided with a loading instrument calibrated in accordance with 3-2-A3/7.

### 3.5 Modifications

Where modifications to the vessel or to the loading/trading pattern affect the required information, a revised or new loading manual is to be submitted and a stamped copy is to be placed aboard the vessel, replacing where applicable the invalidated manual. The loading instrument is to be re-calibrated or newly installed and calibrated in such cases.

Where the difference in the calculated still-water bending moments or shear forces is within  $\pm 2\%$  of the allowable value, those values may be considered as not being affected.

## 5 Loading Manual

### 5.1 Required Information

#### 5.1.1 Permissible Limits

In addition to 3-2-A2/7.1, the loading manual is to include the following information:

5.1.1(a) For single side skin bulk carriers,

- i) The permissible limits of still water bending moments and shear forces in the hold flooded condition in accordance with 5-3-3/3.1 and 5-3-A5a/1.
- ii) The still water bending moment limits are to be presented in the form of an envelope curve for all combinations of loading conditions and flooded holds.

5.1.1(b) The cargo hold(s) or combination of cargo holds that might be empty at full draft. If it is not permitted to have an empty cargo hold at full draft, this is to be clearly stated in the loading manual.

5.1.1(c) Maximum allowable and minimum required mass of contents of each cargo hold and double bottom space in way thereof, as a function of the draft at the mid length of the hold.

5.1.1(d) (1 July 1999) Maximum allowable and minimum required mass of contents of two cargo holds and double bottom spaces forward and aft of any cargo hold bulkhead, as a function of the mean draft. This mean draft may be taken as the average of the drafts at the mid-length of two holds.

#### 5.1.2 Loading Rate and Sequence

5.1.2(a) The maximum rate of ballast change

5.1.2(b) An instruction that a loading plan is to be agreed with the terminal on the basis of the achievable rates of change of ballast.

5.1.2(c) (2000) Typical sequence of loading from commencement to full deadweight or any contemplated part load conditions. Where applicable, homogeneous conditions and alternate loading conditions are to be included. The typical loading sequences shall be developed with due attention being paid to the loading rate, the deballasting capacity and applicable strength limitations. The Annex to this Appendix and 3-2-A3/Table 2 contain, as guidance only, an example of a Loading Sequence Summary Form and aspects that may be considered in developing the sequence.

5.1.2(d) Typical sequences for change of ballast at sea, where applicable.

### 5.3 Loading Conditions (2003)

The above information is to be based on the intended service conditions. See 3-2-A3/Table 1 for the selection of loading conditions, which replaces 3-2-A2/Table 1 for the vessels covered by this Appendix.

## 7 Loading Instrument

### 7.1 Required Verifications

In addition to 3-2-A2/9.3, at least the following aspects are to be demonstrated to the Surveyor for his/her verification:

#### 7.1.1

That the instrument can easily and quickly perform calculations to determine that the permissible values at the specified points along the vessel will not be exceeded in any loaded or ballast condition;

#### 7.1.2

That the relevant limits for the mass of contents of each cargo hold and double bottom spaces in way thereof, as a function of the draft at the mid-hold position, are satisfactory;

#### 7.1.3 (1 July 1999)

That the relevant limits for the mass of contents of two cargo holds and double bottom spaces forward and aft of any cargo hold bulkhead, as a function of the mean draft in way of these holds, are satisfactory;

#### 7.1.4

Where applicable for single side skin bulk carriers, that the relevant limits for the still water bending moments and shear forces in any one hold flooded conditions in accordance with 5-3-3/3.1 and 5-3-A5a/1 are satisfactory.

**TABLE 1**  
**Loading Conditions in the Loading Manual For Bulk Carriers, Ore Carriers and Combination Carriers 150 Meters (492 Feet) and above in Length ( $L_f$ )**

1.	The loading manual is to include at least the following loading conditions, upon which the design of the vessel is based.
1.1	full load conditions, subdivided into departure and arrival conditions
1.1.1	cargoes of typical densities within the expected range
1.1.2	alternate heavy cargo loading condition (see notes 1 & 5 below)
1.1.3	alternate light cargo loading condition (see notes 2 & 5 below)
1.1.4	homogeneous heavy cargo loading (see notes 3 & 5 below)
1.1.5	homogeneous light cargo loading (see notes 4 & 5 below)
1.1.6	short voyages (e.g. half bunker)
1.1.7	deck cargoes
1.2	multiple port loading/unloading conditions, subdivided into departure and arrival conditions (see note 5 below)
1.3	ballast conditions, subdivided into departure and arrival conditions
1.4	critical loading conditions
1.5	intermediate conditions, including but not limited to
1.5.1	before and after any ballasting/deballasting during the voyage
1.5.2	ballast exchange and its sequence {see 3-2-A3/5.1.2(a), (b) and (d)}
1.6	in-port conditions
1.7	docking conditions afloat
2.	The following conditions are to be considered for combination carriers, in addition to the conditions as specified above. The list does not preclude any loading conditions that are necessary for the particular service intended:
2.1	part loaded conditions (see note 5 below)

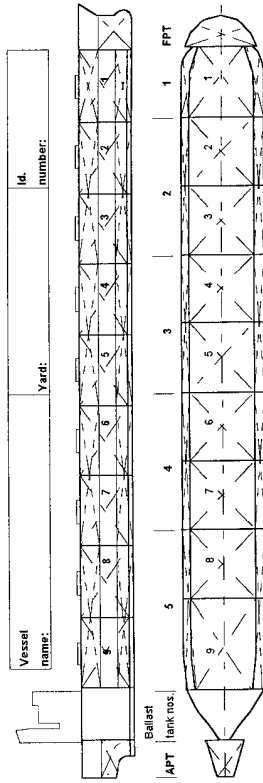
*Notes:*

- 1 Heaviest cargo can be carried and the draft is corresponding to the summer load water line. Loaded holds may not be filled completely with cargo.
- 2 Lightest cargo can be carried at the summer load water line. Loaded holds may or may not be filled completely with cargo.
- 3 (1 July 2003) Heaviest cargo loaded in all cargo holds at the same filling ratio (cargo volume/hold cubic capacity) and at the draft corresponding to the summer load water line. All loaded holds may not be filled up with cargo.
- 4 Homogeneous loading condition. All cargo holds are filled completely with cargo and the draft is corresponding to the summer load water line.
- 5 Conditions during loading/unloading are also to be included.

**TABLE 2**  
**Guidance on Loading/Unloading Sequences (2000)**

1.	In addition to 3-2-A3/5.1.2(c), due attention is to be paid to the following items in the development of typical loading/unloading sequences being submitted for review.
2.	The typical sequences are to include, but not limited to, the following:
-	alternate hold light and heavy cargo condition
-	homogeneous light and heavy cargo condition
-	short voyage (full load with less than full fuel)
-	multiple port loading/unloading
-	deck cargo condition
-	block loading
3.	The sequences may be port specific if so desired.
4.	The sequence should include each and every stage from commencement to full deadweight or vice versa. Whenever the loading/unloading equipment moves to the next location, it constitutes the end of that stage. For each stage, longitudinal as well as local strength of double bottom are to be considered.
5.	for each stage, a summary highlighting the essential information such as the following is to be prepared:
-	the amount of cargo loaded/unloaded during that stage
-	the amount of ballast discharged/ballasted during that stage
-	the still-water bending moment and shearing forces at the end of the stage
-	trim and draft at the end of the stage

ANNEX Guidance on Loading Summary Sequence Form [see 3-2-A3/5.1.2(c)]



Port (specific or typical):	Condition at commencement of loading/discharging:
Total mass of cargo to be loaded/discharged:	Condition at end of loading/discharging:
Dock water density (t/m <sup>3</sup> ):	Maximum Loading/discharging rate:
Number of leads/dischargers:	Maximum Ballasting/Deballasting rate:

Note: During each pour allowable limits for hull girder shear forces, bending moments and mass in holds are not to be exceeded. Loading/discharging operations may have to be suspended temporarily to allow for ballasting/deballasting in order to keep actual values within limits.

Cargo mass	Hold content at commencement of loading/discharging									Ballast content at commencement of loading/discharging					
	Wings or peaks Upper	Lower/Peaks	APT	Ball. no. 5	Ball. no. 4	Hold no. 6	Ball. no. 3	Hold no. 4	Ball. no. 2	Ball. no. 1	FPT	d aft (t)	Trim (m)	d fwd (t)	Maximum S.F. (%)

Pour no./grade	CARGO OPERATIONS									BALLAST OPERATIONS																	
	Hold 9	Hold 8	Hold 7	Hold 6	Hold 5	Hold 4	Hold 3	Hold 2	Hold 1	APT	Ballast tank no. 5	Ballast tank no. 4	Ballast hold no. 6	Ballast tank no. 3	No. 4 Ballast hold	Ballast tank no. 2	Ballast tank no. 1	FPT	d fwd (t)	Trim (m)	d fwd (t)	Maximum S.F. (%)	Maximum B.M. (%)				
1	Upper	Lower/Peak	Upper	Lower/Peak	Upper	Lower/Peak	Upper	Lower/Peak	Upper	Lower/Peak	Upper	Lower/Peak	Upper	Lower/Peak	Upper	Lower/Peak	Upper	Lower/Peak									
2	Upper	Lower/Peak	Upper	Lower/Peak	Upper	Lower/Peak	Upper	Lower/Peak	Upper	Lower/Peak	Upper	Lower/Peak	Upper	Lower/Peak	Upper	Lower/Peak	Upper	Lower/Peak									
3	Upper	Lower/Peak	Upper	Lower/Peak	Upper	Lower/Peak	Upper	Lower/Peak	Upper	Lower/Peak	Upper	Lower/Peak	Upper	Lower/Peak	Upper	Lower/Peak	Upper	Lower/Peak									
4	Upper	Lower/Peak	Upper	Lower/Peak	Upper	Lower/Peak	Upper	Lower/Peak	Upper	Lower/Peak	Upper	Lower/Peak	Upper	Lower/Peak	Upper	Lower/Peak	Upper	Lower/Peak									
5	Upper	Lower/Peak	Upper	Lower/Peak	Upper	Lower/Peak	Upper	Lower/Peak	Upper	Lower/Peak	Upper	Lower/Peak	Upper	Lower/Peak	Upper	Lower/Peak	Upper	Lower/Peak									
6	Upper	Lower/Peak	Upper	Lower/Peak	Upper	Lower/Peak	Upper	Lower/Peak	Upper	Lower/Peak	Upper	Lower/Peak	Upper	Lower/Peak	Upper	Lower/Peak	Upper	Lower/Peak									
7	Upper	Lower/Peak	Upper	Lower/Peak	Upper	Lower/Peak	Upper	Lower/Peak	Upper	Lower/Peak	Upper	Lower/Peak	Upper	Lower/Peak	Upper	Lower/Peak	Upper	Lower/Peak									
8	Upper	Lower/Peak	Upper	Lower/Peak	Upper	Lower/Peak	Upper	Lower/Peak	Upper	Lower/Peak	Upper	Lower/Peak	Upper	Lower/Peak	Upper	Lower/Peak	Upper	Lower/Peak									
...																											
Drift Survey (for loading):	Total amount of bunkers onboard (t):																										
n-1	Upper	Lower/Peak	Upper	Lower/Peak	Upper	Lower/Peak	Upper	Lower/Peak	Upper	Lower/Peak	Upper	Lower/Peak	Upper	Lower/Peak	Upper	Lower/Peak	Upper	Lower/Peak									
n	Upper	Lower/Peak	Upper	Lower/Peak	Upper	Lower/Peak	Upper	Lower/Peak	Upper	Lower/Peak	Upper	Lower/Peak	Upper	Lower/Peak	Upper	Lower/Peak	Upper	Lower/Peak									

Cargo mass	Hold content at end of loading/discharging									Ballast content at end of loading/discharging					
	Wings or peaks Upper <th>Lower/Peaks <th>APT</th> <th>Ball. no. 5</th> <th>Ball. no. 4</th> <th>Hold no. 6</th> <th>Ball. no. 3</th> <th>Hold no. 4</th> <th>Ball. no. 2</th> <th>Ball. no. 1</th> <th>FPT</th> <th>d aft (t)</th> <th>Trim (m)</th> <th>d fwd (t)</th> <th>Maximum S.F. (%)</th> <th>Maximum B.M. (%)</th> </th>	Lower/Peaks <th>APT</th> <th>Ball. no. 5</th> <th>Ball. no. 4</th> <th>Hold no. 6</th> <th>Ball. no. 3</th> <th>Hold no. 4</th> <th>Ball. no. 2</th> <th>Ball. no. 1</th> <th>FPT</th> <th>d aft (t)</th> <th>Trim (m)</th> <th>d fwd (t)</th> <th>Maximum S.F. (%)</th> <th>Maximum B.M. (%)</th>	APT	Ball. no. 5	Ball. no. 4	Hold no. 6	Ball. no. 3	Hold no. 4	Ball. no. 2	Ball. no. 1	FPT	d aft (t)	Trim (m)	d fwd (t)	Maximum S.F. (%)

Approved by:



PART

# 3

CHAPTER **2 Hull Structures and Arrangements**

APPENDIX **4 Buckling Strength of Longitudinal Strength Members (1995)**

## 1 Application

These requirements apply to plate panels and longitudinals subject to hull girder bending and shear stresses.

## 3 Elastic Buckling Stresses

### 3.1 Elastic Buckling of Plates

#### 3.1.1 Compression

The ideal elastic buckling stress is given by:

$$\sigma_E = 0.9mE \left( \frac{t_b}{s} \right)^2 \quad \text{N/mm}^2 \text{ (kgf/mm}^2, \text{ psi)}$$

For plating with longitudinal stiffeners (parallel to compressive stress):

$$m = \frac{8.4}{\Psi + 1.1} \quad \text{for } (0 \leq \Psi \leq 1)$$

For plating with transverse stiffeners (perpendicular to compressive stress):

$$m = c \left[ 1 + \left( \frac{s}{\ell} \right)^2 \right]^2 \frac{2.1}{\Psi + 1.1} \quad \text{for } (0 \leq \Psi \leq 1)$$

where

$$E = 2.06 \times 10^5 \text{ N/mm}^2 \text{ (21,000 kgf/mm}^2, 30 \times 10^6 \text{ psi)}$$

$$t_b = \text{net thickness of plating, in mm (in.), after making standard deductions as given in 3-2-A4/Table 1}$$

$$s = \text{shorter side of plate panel, in mm (in.)}$$

$$\ell = \text{longer side of plate panel, in mm (in.)}$$

- $c$  = 1.3 when plating stiffened by floors or deep girders  
 = 1.21 when stiffeners are angles or T-sections  
 = 1.10 when stiffeners are bulb flats  
 = 1.05 when stiffeners are flat bars  
 $\Psi$  = ratio of smallest to largest compressive stress,  $\sigma_a$  (see 3-2-A4/7.1),  
 varying linearly across panel.

### 3.1.2 Shear

The ideal elastic buckling stress is given by:

$$\tau_E = 0.9k_t E \left( \frac{t_b}{s} \right)^2 \text{ N/mm}^2 \text{ ( kgf/mm}^2 \text{, psi)}$$

where

$$k_t = 5.34 + 4 \left( \frac{s}{\ell} \right)^2$$

$E$ ,  $t_b$ ,  $s$  and  $\ell$  are as defined in 3-2-A4/3.1.1.

## 3.3 Elastic Buckling of Longitudinals

### 3.3.1 Column Buckling without Rotation of the Cross Section

For the column buckling mode (perpendicular to plane of plating), the ideal elastic buckling stress is given by:

$$\sigma_E = \frac{EI_a}{c_1 A \ell^2} \text{ N/mm}^2 \text{ (kgf/mm}^2 \text{, psi)}$$

where

- $I_a$  = moment of inertia, in  $\text{cm}^4$  ( $\text{in}^4$ ), of longitudinal, including plate flange and calculated with thickness, as specified in 3-2-A4/3.1.1  
 $A$  = cross-sectional area, in  $\text{cm}^2$  ( $\text{in}^2$ ), of longitudinal, including plate flange and calculated with thickness, as specified in 3-2-A4/3.1.1  
 $\ell$  = span, in m (ft), of longitudinal  
 $c_1$  = 1000 (1000, 14.4)  
 $E$  = as defined in 3-2-A4/3.1.1

### 3.3.2 Torsional Buckling Mode

The ideal elastic buckling stress for the torsional mode is given by:

$$\sigma_E = \frac{\pi^2 EI_w}{10c_1 I_p \ell^2} \left( m^2 + \frac{K}{m^2} \right) + 0.385E \frac{I_t}{I_p} \text{ N/mm}^2 \text{ (kgf/mm}^2 \text{, psi)}$$

where

$$K = c_2 \frac{C \ell^4}{\pi^4 EI_w}$$

- $m$  = number of half waves given by 3-2-A4/Table 2
- $E$  = as defined in 3-2-A4/3.1.1
- $c_2$  =  $10^6$  ( $10^6$ , 20736)
- $I_t$  = St. Venant's moment of inertia, in  $\text{cm}^4$  ( $\text{in}^4$ ), of profile (without plate flange)
- =  $c_3 \frac{h_w t_w^3}{3}$  for flat bars (slabs)
- =  $c_3 \frac{1}{3} \left[ h_w t_w^3 + b_f t_f^3 \left( 1 - 0.63 \frac{t_f}{b_f} \right) \right]$  for flanged profiles
- $c_3$  =  $10^{-4}$  ( $10^{-4}$ , 1.0)
- $I_p$  = polar moment of inertia, in  $\text{cm}^4$  ( $\text{in}^4$ ), of profile about connection of stiffener to plate
- =  $c_3 \frac{h_w^3 t_w}{3}$  for flat bars (slabs)
- =  $c_3 \left( \frac{h_w^3 t_w}{3} + h_w^2 b_f t_f \right)$  for flanged profiles
- $I_w$  = warping constant, in  $\text{cm}^6$  ( $\text{in}^6$ ), of profile about connection of stiffener to plate
- =  $c_4 \frac{h_w^3 t_w^3}{36}$  for flat bars (slabs)
- =  $c_4 \left( \frac{t_f b_f^3 h_w^2}{12} \right)$  for "Tee" profiles
- =  $c_4 \frac{b_f^3 h_w^2}{12 (b_f + h_w)^2} [t_f (b_f^2 + 2b_f h_w + 4h_w^2) + 3t_w b_f h_w]$  for angles and bulb profiles
- $c_4$  =  $10^{-6}$  ( $10^{-6}$ , 1.0)
- $h_w$  = web height, in mm (in.)
- $t_w$  = web thickness, in mm (in.), after making standard deductions, as specified in 3-2-A4/3.1.1
- $b_f$  = flange width, in mm (in.)
- $t_f$  = flange thickness, in mm (in.), after making standard deductions, as specified in 3-2-A4/3.1.1. For bulb profiles the mean thickness of the bulb may be used.
- $\ell$  = span of profile, in m (ft)
- $s$  = spacing of profiles, in mm (in.)

$$C = \text{spring stiffness exerted by supporting plate panel}$$

$$= \frac{k_p E t_p^3}{3s \left( 1 + \frac{1.33 k_p h_w t_p^3}{s t_w^3} \right)} \quad \text{N (kgf, lbf)}$$

$$k_p = 1 - \eta_p, \text{ not to be taken less than zero}$$

$$t_p = \text{plate thickness, in mm (in.), after making standard deductions, as specified in 3-2-A4/3.1.1}$$

$$\eta_p = \frac{\sigma_a}{\sigma_{Ep}}$$

$$\sigma_a = \text{calculated compressive stress. For longitudinals, see 3-2-A4/7.1}$$

$$\sigma_{Ep} = \text{elastic buckling stress of supporting plate, as calculated in 3-2-A4/3.1}$$

For flanged profiles,  $k_p$  need not be taken less than 0.1.

### 3.3.3 Web and Flange Buckling

For web plate of longitudinals the ideal buckling stress is given by:

$$\sigma_E = 3.8E \left( \frac{t_w}{h_w} \right)^2 \quad \text{N/mm}^2 \text{ (kgf/mm}^2, \text{ psi)}$$

For flanges on angles and T-sections of longitudinals, the following requirements will apply:

$$\frac{b_f}{t_f} \leq 15$$

$b_f$  = flange width, in mm (in.), for angles, half the flange width for T-sections.

$t_f$  = as built flange thickness, in mm (in.)

**TABLE 1**  
**Standard Deduction**

Structure	Standard Deduction	Limit Values min.-max. in mm (in.)
— Compartments carrying dry bulk cargoes	0.05t	0.5–1.0
— One side exposure to ballast and/or liquid cargo Vertical surfaces and surfaces sloped at an angle greater than 25° to the horizontal line		(0.02–0.04)
— One side exposure to ballast and/or liquid cargo Horizontal surfaces and surfaces sloped at an angle less than 25° to the horizontal line	0.10t	2.0–3.0 (0.08–0.12)
— Two side exposure to ballast and/or liquid cargo Vertical surfaces and surfaces sloped at an angle greater than 25° to the horizontal line		
— Two side exposure to ballast and/or liquid cargo Horizontal surfaces and surfaces sloped at an angle less than 25° to the horizontal line	0.15t	2.0–4.0 (0.08–0.16)

**TABLE 2**  
**Number of Half Waves**

	$0 < K \leq 4$	$4 < K \leq 36$	$36 < K \leq 144$	$144 < K \leq 400$	$(m-1)^2 < m^2 < K \leq m^2(m+1)^2$
$m$	1	2	3	4	$m$

## 5 Critical Buckling Stresses

### 5.1 Compression

The critical buckling stress in compression,  $\sigma_c$ , is determined as follows:

$$\begin{aligned} \sigma_c &= \sigma_E && \text{when } \sigma_E \leq \frac{\sigma_F}{2} \\ &= \sigma_F \left( 1 - \frac{\sigma_F}{4\sigma_E} \right) && \text{when } \sigma_E > \frac{\sigma_F}{2} \end{aligned}$$

where

$\sigma_F$  = yield stress of material, in N/mm<sup>2</sup> (kgf/mm<sup>2</sup>, psi).  $\sigma_F$  may be taken as 235 N/mm<sup>2</sup> (24 kgf/mm<sup>2</sup>, 34,000 psi) for mild steel.

$\sigma_E$  = ideal elastic buckling stress calculated according to 3-2-A4/3

### 5.3 Shear

The critical buckling stress in shear,  $\tau_c$ , is determined as follows:

$$\begin{aligned} \tau_c &= \tau_E && \text{when } \tau_E \leq \frac{\tau_F}{2} \\ &= \tau_F \left( 1 - \frac{\tau_F}{4\tau_E} \right) && \text{when } \tau_E > \frac{\tau_F}{2} \end{aligned}$$

where

$$\tau_F = \frac{\sigma_F}{\sqrt{3}}$$

$\sigma_F$  = as given in 3-2-A4/5.1

$\tau_E$  = ideal elastic buckling stress in shear calculated according to 3-2-A4/3.1.2

## 7 Working Stress

### 7.1 Longitudinal Compressive Stress

The compressive stresses are given in the following formula:

$$\sigma_a = c_5 \frac{M_w + M_{sw}}{I_n} y \quad \text{N/mm}^2 \text{ (kgf/mm}^2, \text{ psi)}$$

$$= \text{minimum } 30/Q \text{ N/mm}^2 \text{ (3.1/Q kgf/mm}^2, \text{ 4400/Q psi)}$$

where

- $M_{sw}$  = still water bending moment, as given in 3-2-1/3.7.1(a), in kN-m (tf-m, Ltf-ft)
- $M_w$  = wave bending moment, as given in 3-2-1/3.7.1(a), in kN-m (tf-m, Ltf-ft)
- $I_n$  = moment of inertia, in  $\text{cm}^4$  ( $\text{in}^4$ ), of the hull girder
- $y$  = vertical distance, in m (ft), from the neutral axis to the considered point
- $Q$  = as defined in 3-2-1/5.5 (1.0 for ordinary strength steel)
- $c_5$  =  $10^5$  ( $10^5$ , 322,560)

$M_w$  and  $M_{sw}$  are to be taken as sagging or hogging bending moments, respectively, for members above or below the neutral axis.

### 7.3 Shear Stresses

#### 7.3.1 Vessels without Effective Longitudinal Bulkheads

The working shear stress,  $\tau_a$ , in the side shell of vessels without effective longitudinal bulkheads is given by the following formula:

$$\tau_a = c_6 \frac{(F_{sw} + F_w) m_s}{2t_s I} \quad \text{N/mm}^2 \text{ (kgf/mm}^2, \text{ psi)}$$

where

- $I$  = moment of inertia of the hull girder section, in  $\text{cm}^4$  ( $\text{in}^4$ ), at the section under consideration.
- $m_s$  = first moment, in  $\text{cm}^3$  ( $\text{in}^3$ ), about the neutral axis of the area of the effective longitudinal material between the horizontal level at which the shear stress is being determined and the vertical extremity of effective longitudinal material, taken at the position under consideration.
- $t_s$  = thickness of the side shell plating, in cm (in.), at the position under consideration.
- $F_{sw}$  = hull girder shearing force in still water, in kN (tf, Ltf). See 3-2-1/3.3.
- $F_w$  =  $F_{wp}$  or  $F_{wn}$ , in kN (tf, Ltf), as specified by 3-2-1/3.5.3, depending upon loading
- $c_6$  = 10 (10, 2240)

### 7.3.2 Vessels with Two or More Effective Longitudinal Bulkheads

The working shear stress,  $\tau_a$ , in the side shell or longitudinal bulkhead plating is to be calculated by an acceptable method and in accordance with 3-2-1/3.9.4.

## 9 Scantling Criteria

### 9.1 Buckling Stress

The design buckling stress,  $\sigma_c$ , of plate panels and longitudinals (as calculated in 3-2-A4/5.1) is to be such that:

$$\sigma_c \geq \beta \sigma_a$$

where

$$\begin{aligned} \beta &= 1 && \text{for plating and for web plating of stiffeners (local buckling)} \\ &= 1.1 && \text{for stiffeners} \end{aligned}$$

The critical buckling stress,  $\tau_c$ , of plate panels (as calculated in 3-2-A4/5.3) is to be such that:

$$\tau_c \geq \tau_a$$

where

$$\tau_a = \text{working shear stress in the plate panel under consideration, in N/mm}^2 \text{ (kgf/mm}^2 \text{, lbf/in}^2 \text{), as determined by 3-2-A4/7.3.}$$

This Page Intentionally Left Blank



PART

**3**

CHAPTER **2 Hull Structures and Arrangements**

SECTION **2 Shell Plating**

**1 Application**

Shell plating is to be of not less thickness than is required for purposes of longitudinal hull girder strength; nor is it to be less than is required by this section. In general, the shell plating is not to be less in thickness than required by 3-2-10/3.1 for deep tanks. For bottom shell plating bounding tanks having normal tank/air vent configurations in order to avoid accidental overpressure, the head “*h*” need not be greater than the distance from the plate under consideration to the deck at side. In the case of unusual configurations, or where the tanks are intended to carry liquids having a specific gravity equal to or greater than 1.05 t/m<sup>3</sup>, “*h*” should be in accordance with 3-2-10/3.1.

**3 Shell Plating Amidships**

**3.1 Vessels with No Partial Superstructures Above Uppermost Continuous Deck**

In vessels that have no partial superstructures above the uppermost continuous deck, the thickness of the bottom and side plating is to be obtained from the appropriate equations where  $D_s$  is the molded depth, in m (ft), measured to the uppermost continuous deck.

**3.3 Superstructures Fitted Above Uppermost Continuous Deck (Side Plating Extended)**

Where superstructures are fitted above the uppermost continuous deck to which the side plating extends throughout the amidship  $0.4L$ , the thickness of the bottom and side plating is to be obtained from the appropriate equations where  $D_s$  is the molded depth, in m (ft), measured to the superstructure deck. In such cases, the sheer strake beyond the superstructure is to be proportioned from the thickness as required for the sheer strake amidships, where  $D_s$  is measured to the uppermost continuous deck.

**3.5 Superstructures Fitted Above Uppermost Continuous Deck (Side Plating Not Extended)**

Where superstructures are fitted above the uppermost continuous deck, to which the side plating does not extend throughout the amidship  $0.4L$ , the thickness of the bottom and side plating is to be obtained from the appropriate equations where  $D_s$  is the molded depth, in m (ft), measured to the uppermost continuous deck.

### 3.7 In Way of Comparatively Short Superstructures

In way of comparatively short superstructure decks, or where the superstructure deck is not designed as the strength deck, the thickness of the bottom and side plating is to be obtained from the appropriate equations where  $D_s$  is the molded depth, in m (ft), measured to the uppermost continuous deck. In such cases, the thickness of the side plating above the uppermost continuous deck is to be specially considered, but in no case is the thickness to be less than that obtained from equations 1a and 1b in 3-2-3/Table 2, but substituting the frame spacing, in mm (in.), for  $s_b$  in lieu of the deck beam spacing.

### 3.9 Side Shell Plating

The minimum thickness,  $t$ , of the side shell plating throughout the amidship  $0.4L$ , for vessels having lengths not exceeding 427 m (1400 ft), is to be obtained from the following equations:

$$t = (s/645) \sqrt{(L - 15.2)(d / D_s)} + 2.5 \text{ mm} \quad \text{for } L \leq 305 \text{ m}$$

$$t = (s/828) \sqrt{(L + 175)(d / D_s)} + 2.5 \text{ mm} \quad \text{for } 305 < L \leq 427 \text{ m}$$

$$t = (s/1170) \sqrt{(L - 50)(d / D_s)} + 0.1 \text{ in.} \quad \text{for } L \leq 1000 \text{ ft}$$

$$t = (s/1500) \sqrt{(L + 574)(d / D_s)} + 0.1 \text{ in.} \quad \text{for } 1000 < L \leq 1400 \text{ ft}$$

where

- $s$  = spacing of transverse frames or longitudinals, in mm (in.)
- $L$  = length of vessel, as defined in 3-1-1/3.1, in m (ft)
- $d$  = molded draft, as defined in 3-1-1/9, in m (ft)
- $D_s$  = molded depth, in m (ft), as defined in 3-2-2/3.1 through 3-2-2/3.7

The actual ratio of  $d/D_s$  is to be used in the above equations, except that the ratio is not to be taken less than  $0.0433 L/D_s$ .

The side shell thickness amidships is to be not less than the thickness obtained by 3-2-2/5.1 using 610 mm (24 in.) as the frame spacing.

### 3.11 Sheer Strake

The minimum width,  $b$ , of the sheer strake throughout the amidship  $0.4L$  is to be obtained from the following equations:

$$b = 5L + 800 \text{ mm} \quad \text{for } L < 200 \text{ m}$$

$$b = 1800 \text{ mm} \quad \text{for } 200 \leq L \leq 427 \text{ m}$$

$$b = 0.06L + 31.5 \text{ in.} \quad \text{for } L < 656 \text{ ft}$$

$$b = 71 \text{ in.} \quad \text{for } 656 \leq L \leq 1400 \text{ ft}$$

where

- $L$  = length of vessel, as defined in 3-1-1/3.1, in m (ft)
- $b$  = width of sheer strake, in mm (in.)

In general, the thickness of the sheer strake is not to be less than the thickness of the adjacent side shell plating, nor is it to be less than required by equation 1b or 2b in 3-2-3/Table 2, as appropriate, from *Decks-A* of 3-2-3/Table 1. The thickness of the sheer strake is to be increased 25% in way of breaks of superstructures, but this increase need not exceed 6.5 mm (0.25 in.). Where breaks in way of the forecastle or poop are appreciably beyond the amidship  $0.5L$ , this requirement may be modified.

The top edge of the sheer strake is to be smooth and free of notches. Fittings and bulwarks are not to be welded to the top of the sheer strake within the amidships  $0.8L$ , nor in way of superstructure breaks throughout.

### 3.13 Bottom Shell Plating Amidships

#### 3.13.1 Extent of Bottom Plating Amidships

The term “bottom plating amidships” refers to the bottom shell plating from the keel to the upper turn of the bilge, extending over the amidships  $0.4L$ .

#### 3.13.2 Bottom Shell Plating

The thickness,  $t$ , of the bottom plating amidships is not to be less than obtained from the following equations or the thickness determined by 3-2-2/3.17, whichever is greater.

##### 3.13.2(a) For Vessels with Transversely-framed Bottoms

$$t = (s/519) \sqrt{(L - 19.8)(d / D_s)} + 2.5 \text{ mm} \quad \text{for } L \leq 183 \text{ m}$$

$$t = (s/940) \sqrt{(L - 65)(d / D_s)} + 0.1 \text{ in.} \quad \text{for } L \leq 600 \text{ ft}$$

##### 3.13.2(b) For Vessels with Longitudinally-framed Bottoms

$$t = (s/671) \sqrt{(L - 18.3)(d / D_s)} + 2.5 \text{ mm} \quad \text{for } L \leq 122 \text{ m}$$

$$t = (s/508) \sqrt{(L - 62.5)(d / D_s)} + 2.5 \text{ mm} \quad \text{for } 122 \leq L \leq 305 \text{ m}$$

$$t = (s/661) \sqrt{(L + 105)(d / D_s)} + 2.5 \text{ mm} \quad \text{for } 305 < L \leq 427 \text{ m}$$

$$t = (s/1215) \sqrt{(L - 60)(d / D_s)} + 0.1 \text{ in.} \quad \text{for } L < 400 \text{ ft}$$

$$t = (s/920) \sqrt{(L - 205)(d / D_s)} + 0.1 \text{ in.} \quad \text{for } 400 \leq L \leq 1000 \text{ ft}$$

$$t = (s/1197) \sqrt{(L + 344.5)(d / D_s)} + 0.1 \text{ in.} \quad \text{for } 1000 < L \leq 1400 \text{ ft}$$

where  $L$ ,  $d$ ,  $s$  and  $D_s$  are as defined in 3-2-2/3.9.

The actual ratio of  $d/D_s$  is to be used in the above equations, but the ratio is not to be taken less than  $0.0433 L/D_s$ .

After all corrections have been made, the bottom shell thickness amidships is not to be less than the thickness obtained by 3-2-2/5.1 using 610 mm (24 in.) as the frame spacing.

Where the actual bottom hull girder section modulus  $SM_A$  is greater than required by 3-2-1/3.7.1, and still-water bending moment calculations are submitted, the thickness of the bottom shell may be obtained from the above equations multiplied by the factor  $R_n$  defined as follows:

$$R_n = \sqrt{\frac{1}{(f_p / \sigma_t)(1 - SM_R / SM_A) + 1}} \quad \text{but is not to be taken less than 0.85} \quad (d/D_s \geq 0.65)$$

$$= 1.0 \quad (d/D_s \leq 0.0433 L/D_s)$$

$$= \text{by linear interpolation} \quad (0.0433 L/D_s < d/D_s < 0.65)$$

where

- $f_p$  = nominal permissible bending stress, in kN/cm<sup>2</sup> (tf/cm<sup>2</sup>, Ltf/in<sup>2</sup>), as given in 3-2-1/3.7.1
- $\sigma_t$  =  $K P_t (s/t)^2$ , in kN/cm<sup>2</sup> (tf/cm<sup>2</sup>, Ltf/in<sup>2</sup>)
- $K$  = 0.5 for transverse framing and 0.34 for longitudinal framing
- $P_t$  =  $(0.638H + d)a$  kN/cm<sup>2</sup> (tf/cm<sup>2</sup>, Ltf/in<sup>2</sup>)
- $a$  =  $1.005 \times 10^{-3}$  ( $1.025 \times 10^{-4}$ ,  $1.984 \times 10^{-4}$ )
- $SM_R$  = hull girder section modulus required by 3-2-1/3.7.1, in cm<sup>2</sup>-m (in<sup>2</sup>-ft)
- $SM_A$  = bottom hull girder section modulus, in cm<sup>2</sup>-m (in<sup>2</sup>-ft), of the vessel with the greater of the bottom shell plating thickness obtained when applying  $R_n$  or  $R_b$
- $t$  = bottom shell plating thickness required by 3-2-2/3.13.2(a) or 3-2-2/3.13.2(b), in mm (in.)
- $H$  = wave parameter, in m (ft)
- |                                       |    |                    |
|---------------------------------------|----|--------------------|
| $= 0.0172L + 3.653$                   | m  | 90 ≤ L ≤ 150 m     |
| $= 0.0181L + 3.516$                   | m  | 150 < L ≤ 220 m    |
| $= [4.50L - 0.0071L^2 + 103]10^{-2}$  | m  | 220 < L ≤ 305 m    |
| $= 8.151$                             | m  | 305 < L ≤ 427 m    |
|                                       |    |                    |
| $= 0.0172L + 11.98$                   | ft | 295 < L ≤ 490 ft   |
| $= 0.0181L + 11.535$                  | ft | 490 ≤ L ≤ 720 ft   |
| $= [4.50L - 0.00216L^2 + 335]10^{-2}$ | ft | 720 < L ≤ 1000 ft  |
| $= 26.750$                            | ft | 1000 < L ≤ 1400 ft |

$L$ ,  $d$  and  $D_s$  are as defined in 3-2-2/3.9.

$R_b$  is defined in 3-2-2/3.17.2.

$SM_R/SM_A$  is not to be taken as less than 0.70

Special consideration will be given to vessels constructed of higher-strength steel.

### 3.15 Flat Plate Keel (1997)

The thickness of the flat plate keel is to be 1.5 mm (0.06 in.) greater than that required for the bottom shell plating at the location under consideration. This 1.5 mm (0.06 in.) increase in thickness is not required where the submitted docking plan specifies that all docking blocks are to be arranged clear of the flat plate keel. See 3-1-2/11 and 3-2-2/7.

### 3.17 Minimum Thickness

After all other requirements are met, the thickness,  $t_{\min}$ , of the shell plating amidships below the upper turn of bilge is not to be less than obtained from the following equations:

#### 3.17.1 Transverse Framing

$$t_{\min} = s(L + 45.73)/(25L + 6082) \text{ mm} \quad \text{for } L \leq 183 \text{ m}$$

$$t_{\min} = s(L + 150)/(25L + 19950) \text{ in.} \quad \text{for } L \leq 600 \text{ ft}$$

where

$$s = \text{frame spacing, in mm (in.), but is not to be less than that given in 3-2-5/1.7}$$

$$L = \text{length of vessel, as defined in 3-1-1/3.1, in m (ft)}$$

#### 3.17.2 Longitudinal Framing

$$t_{\min} = s(L - 18.3)/(42L + 1070) \text{ mm} \quad \text{for } L \leq 427 \text{ m}$$

$$t_{\min} = s(L - 60)/(42L + 3510) \text{ in.} \quad \text{for } L \leq 1400 \text{ ft}$$

where

$$s = \text{frame spacing, in mm (in.), but is not to be less than 88\% of that given in 3-2-5/1.7 or 813 mm (32 in.), whichever is less}$$

$$L = \text{length of vessel, as defined in 3-1-1/3.1, in m (ft)}$$

Where the bottom hull girder section modulus  $SM_A$  is greater than required by 3-2-1/3.7.1, and still-water bending moment calculations are submitted, the thickness of bottom shell plating amidships, obtained from the above equations, may be multiplied by the factor,  $R_b$ .

$$R_b = \sqrt{SM_R / SM_A} \quad \text{but is not to be taken less than 0.85} \quad (d/D_s \geq 0.65)$$

$$= 1.0 \quad (d/D_s \leq 0.0433L/D_s)$$

$$= \text{by linear interpolation} \quad (0.0433L/D_s < d/D_s < 0.65)$$

where  $SM_R$  and  $SM_A$  are as defined in 3-2-2/3.13.2.

For transverse framing,  $R_b$  is to be not less than  $1.2285 - L/533.55$  for SI or MKS units ( $1.2285 - L/1750$  for US units),

where  $L$  is as defined above, but is not to be taken as less than 122 m (400 ft).

Special consideration will be given to vessels constructed of higher-strength steel.

## 5 Shell Plating at Ends

### 5.1 Minimum Shell Plating Thickness

The minimum shell plating thickness  $t$  at the ends is to be obtained from the following equations and is not to extend for more than  $0.1L$  at the ends. Between the amidship  $0.4L$  and the end  $0.1L$ , the thickness of the plating may be gradually tapered.

$$t = 0.035(L + 29) + 0.009s \text{ mm} \quad \text{for } 90 \leq L \leq 305 \text{ m}$$

$$t = (11.70 + 0.009s)\sqrt{D/35} \text{ mm} \quad \text{for } 305 < L \leq 427 \text{ m}$$

$$t = 0.00042(L + 95) + 0.009s \text{ in.} \quad \text{for } 295 \leq L \leq 1000 \text{ ft}$$

$$t = (0.46 + 0.009s)\sqrt{D/114.8} \text{ in.} \quad \text{for } 1000 < L \leq 1400 \text{ ft}$$

where

$s$  = fore or aft peak frame spacing, in mm (in.)

$L$  = length of vessel, as defined in 3-1-1/3.1, in m (ft)

$D$  = molded depth, in m (ft), as defined in 3-1-1/7.1 or 35 m (114.8 ft), whichever is greater

Where the strength deck at the ends is above the freeboard deck, the thickness of the side plating above the freeboard deck may be reduced to the thickness given for forecastle and poop sides at the forward and after ends respectively.

### 5.3 Immersed Bow Plating

The thickness  $t$  of the plating below the load waterline forward of  $0.16L$  from the stem is not to be less than is given by the following equation, but need not be greater than the thickness of the side shell plating amidships.

$$t = 0.05(L + 20) + 0.009s \text{ mm} \quad \text{for } 90 \leq L \leq 305 \text{ m}$$

$$t = (16.25 + 0.009s)\sqrt{D/35} \text{ mm} \quad \text{for } 305 < L \leq 427 \text{ m}$$

$$t = 0.0006(L + 66) + 0.009s \text{ in.} \quad \text{for } 295 \leq L \leq 1000 \text{ ft}$$

$$t = (0.64 + 0.009s)\sqrt{D/114.8} \text{ in.} \quad \text{for } 1000 < L \leq 1400 \text{ ft}$$

where

$s$  = fore peak frame spacing, in mm (in.)

$L$  = length of vessel, as defined in 3-1-1/3.1, in m (ft)

$D$  = molded depth, in m (ft), as defined in 3-1-1/7.1 or 35 m (114.8 ft), whichever is greater

### 5.5 Bottom Forward

Where the heavy weather ballast draft forward is less than  $0.04L$  m (ft), the plating on the flat of bottom forward, forward of the location given in 3-2-4/Table 1 is to be not less than required by the following equation:

$$t = 0.0046s\sqrt{(0.005L_1^2 - 1.3d_f^2)/d_f} \text{ mm}$$

$$t = 0.0026s\sqrt{(0.005L_1^2 - 1.3d_f^2)/d_f} \text{ in.}$$

where

$s$  = frame spacing, in mm (in.)

$L_1$  = length of vessel, as defined in 3-1-1/3.1, in m (ft), but need not be taken greater than 214 m (702 ft)

$L$  = length of vessel, as defined in 3-1-1/3.1, in m (ft)

$d_f$  = heavy weather ballast draft at the forward perpendicular, in m (ft)

=  $d_f \times 214/L$  m ( $d_f \times 702/L$  ft), where  $L > 214$  m (702 ft)

The required thickness of the flat of bottom forward plating is also to be in accordance with the requirements given by 3-2-2/3.13, 3-2-2/5.1 and 3-2-2/5.3, as appropriate.

### 5.7 Forecastle Side Plating

The thickness,  $t$ , of the plating is to be not less than obtained from the following equations.

$$t = 0.05(L + 76) + 0.006(s - S) \text{ mm} \quad L < 106.5 \text{ m}$$

$$t = 0.035(L + 154) + 0.006(s - S) \text{ mm} \quad L \geq 106.5 \text{ m}$$

$$t = 0.0006(L + 250) + 0.006(s - S) \text{ in.} \quad L < 350 \text{ ft}$$

$$t = 0.00042(L + 505) + 0.006(s - S) \text{ in.} \quad L \geq 350 \text{ ft}$$

where

- $s$  = spacing of longitudinal or transverse frames, in mm (in.)
- $S$  = standard frame spacing, in mm (in.), given by the equation in 3-2-5/1.7 with an upper limit of 1070 mm (42.5 in.), except that in way of the fore peak, the standard frame spacing is not to exceed 610 mm (24 in.)
- $L$  = length of vessel, as defined in 3-1-1/3.1, in m (ft), but need not be taken more than 305 m (1000 ft.)

### 5.9 Poop Side Plating

The thickness,  $t$ , of the plating is to be not less than obtained from the following equation:

$$t = 0.0315(L + 150) + 0.006(s - S) \text{ mm.} \quad L \geq 90 \text{ m}$$

$$t = 0.00038(L + 493) + 0.006(s - S) \text{ in.} \quad L \geq 295 \text{ ft}$$

where

- $s$  = spacing of longitudinal or transverse frames, in mm (in.)
- $S$  = standard frame spacing, in mm (in.), given by the equation in 3-2-5/1.7 with an upper limit of 1070 mm (42.5 in.), except that in way of the aft peak, the standard frame spacing is not to exceed 610 mm (24 in.)
- $L$  = length of vessel, as defined in 3-1-1/3.1, in m (ft), but need not be taken more than 305 m (1000 ft)

### 5.11 Bow and Stern Thruster Tunnels

The thickness of the tunnel plating is not to be less than required by 3-2-2/5.1, where  $s$  is to be taken as the standard frame spacing given by the equation in 3-2-5/1.7, nor is the thickness to be less than obtained from the following equation:

$$t = 0.008d + 3.3 \text{ mm}$$

$$t = 0.008d + 0.13 \text{ in.}$$

where

- $d$  = inside diameter of the tunnel, in mm (in.), or 968 mm (38 in.), whichever is greater

Where the outboard ends of the tunnel are provided with bars or grids, the bars or grids are to be effectively secured.

### 5.13 Special Heavy Plates

Special heavy plates of the thickness,  $t$ , given in the following equations, are to be introduced at the attachments to the stern frame for heel and boss plates, and in way of spectacle bossing. Heavy plates may also be required to provide increased lateral support in the vicinity of the stern tube in vessels of fine form and high power. Thick or double plating is to be fitted around hawse pipes, of sufficient breadth to prevent damage from the flukes of stockless anchors.

#### 5.13.1 Spectacle Bossing

$$t = 0.088(L - 23) + 0.009s \text{ mm} \quad \text{for } 90 < L \leq 427 \text{ m}$$
$$t = 0.00106(L - 75) + 0.009s \text{ in.} \quad \text{for } 295 < L \leq 1400 \text{ ft}$$

where

$$L = \text{length of vessel, as defined in 3-1-1/3.1, in m (ft)}$$
$$s = \text{frame spacing, in mm (in.)}$$

#### 5.13.2 Other Plates on Stern Frame

$$t = 0.094(L - 16) + 0.009s \text{ mm} \quad \text{for } 90 < L \leq 427 \text{ m}$$
$$t = 0.00113(L - 53) + 0.009s \text{ in.} \quad \text{for } 295 < L \leq 1400 \text{ ft}$$

where

$$L = \text{length of vessel, as defined in 3-1-1/3.1, in m (ft)}$$
$$s = \text{frame spacing, in mm (in.)}$$

#### 5.13.3 Boss and Heel Plates

The thickness of the boss and heel plating is to be at least 20% greater than the thickness of spectacle bossing obtained in 3-2-2/5.13.1.

## 7 Bottom Shell Plating for Special Docking Arrangement (1997)

Where it is not intended to use keel blocks when drydocking the vessel, the increase to the keel plate thickness in 3-2-2/3.15 will not be required. However, the thickness of the bottom shell plating strakes in way of the docking blocks to be used in lieu of keel blocks when drydocking the vessel is to be increased by 1.5 mm (0.06 in.). In such instances, the recommended docking arrangement is to be indicated on the structural plans submitted for approval and also on the docking plan to be furnished to the vessel.

## 9 Compensation

Compensation is to be made where necessary for openings in the shell. All openings are to have well-rounded corners. Those for cargo, gangway, fueling ports, etc. are to be kept well clear of discontinuities in the hull girder. Local provision is to be made to maintain the longitudinal and transverse strength of the hull. Where it is proposed to fit port-lights in the shell plating, the locations and sizes are to be clearly indicated on the midship-section drawing when first submitted for approval.



## 11 Breaks

Vessels having partial superstructures are to be specially strengthened in way of breaks to limit the local increase in stresses at these locations. The stringer plate thickness and the sheer strake thickness at the lower level is to be doubled or increased in thickness well beyond the break in both directions. The thickness increase is to be 25% in way of breaks in the superstructures, but the increase need not exceed 6.5 mm (0.25 in.). The side plating of the superstructure is to be increased in thickness in way of the break. The side shell plating below the sheer strake and in way of the break is to be increased appropriately and is to extend well beyond the end of the superstructure in such a fashion as to provide a long gradual taper. Where the breaks of the forecastle or poop are appreciably beyond the amidship  $0.5L$ , these requirements may be modified. Gangways, large freeing ports and other openings in the shell or bulwarks are to be kept well clear of breaks, and any holes which must unavoidably be cut in the plating are to be kept as small as possible and are to be circular or oval in form.

## 13 Bilge Keels

Bilge keels where fitted, are to be attached to the shell by a doubler. In general, both the bilge keel and the doubler are to be continuous. The connections of the bilge keel to the doubler and the doubler to the shell, are to be by double continuous fillet welds.

Butt welds in the bilge keel and doubler are to be full penetration and are to be kept clear of master erection butts. In general, shell butts are to be flush in way of the doubler, and doubler butts are to be flush in way of the bilge keel. In general, scallops and cutouts are not to be used. Where desired, a drilled crack arresting hole, at least 25 mm (1 in.) in diameter, may be provided in the bilge keel butt weld as close as practicable to the doubler.

The ends of the bilge keel are to be suitably tapered and are to terminate on an internal stiffening member. The material tensile properties for bilge keels and doublers are to be as required for the bottom shell plating.

## 15 Higher-strength Materials

### 15.1 General

In general, applications of higher-strength materials for shell plating are to take into consideration the suitable extension of the higher-strength material above and below the bottom and deck, respectively, as required by 3-2-1/5.1. Calculations to show adequate provision against buckling are to be submitted. Care is to be exercised against the adoption of reduced thickness of material that might be subject to damage during normal operation. The thickness of the bottom and side shell plating, where constructed of higher-strength materials, is to be not less than required for the purpose of longitudinal hull girder strength; nor is the thickness to be less than required by the foregoing paragraphs of this section when modified as indicated in 3-2-2/15.3 and 3-2-2/15.5.

### 15.3 Bottom Plating of Higher-strength Material

Bottom shell plating where constructed of higher-strength material is to be not less in thickness than obtained from the following equation:

$$t_{hts} = (t_{ms} - C) Q + C$$

where

$$t_{hts} = \text{thickness of higher-strength material, in mm (in.)}$$

$t_{ms}$  = thickness, in mm (in.), of ordinary-strength steel, as required by the preceding paragraphs of this section.

The requirements  $t_{\min}$  or  $t$  given, respectively, in 3-2-2/3.17 and 5-2-2/3.1.1(a) are to be used in the above equation with the factor  $0.92 / \sqrt{Q}$  substituted for  $Q$ . The value of  $0.92 / \sqrt{Q}$  is not to be less than 1.00.

$C$  = 4.3 mm (0.17 in.)

$Q$  = as defined in 3-2-1/5.5

Where the bottom shell plating is transversely framed, the thickness will be specially considered.

### 15.5 Side Plating of Higher-strength Material

Side-shell plating where constructed of higher-strength material is to be not less in thickness than obtained from the following equation:

$$t_{hs} = [t_{ms} - C] [(Q + 2\sqrt{Q})/3] + C$$

$t_{hs}$ ,  $t_{ms}$ ,  $C$  and  $Q$  are as defined in 3-2-2/15.3

Where the side-shell plating is transversely framed, the thickness will be specially considered.

### 15.7 End Plating

End-plating thickness, including immersed bow plating and plating on the flat of bottom forward, where constructed of higher-strength materials, will be subject to special consideration.

PART

# 3

CHAPTER **2 Hull Structures and Arrangements**

SECTION **3 Decks**

**1 General** (1997)

**1.1 Extent of Plating**

All exposed decks, portions of decks forming the crowns of machinery spaces, and the boundaries of tanks or steps in bulkheads are to be plated. Decks in other locations are to be plated, as necessary, for strength or watertightness.

**3 Hull Girder Strength**

**3.1 Longitudinal Section Modulus Amidships**

The required longitudinal hull girder section modulus amidships is obtained from the equations given in 3-2-1/3.7.1 and 3-2-1/5.5

**3.3 Strength Deck**

For the definition of the strength deck for calculation purposes, see 3-2-1/11.1.

**3.5 Longitudinally Framed Decks**

Where the beams of the strength deck and other decks are fitted longitudinally in accordance with Section 3-2-7, the sectional area of effectively developed deck longitudinals may be included in the hull girder section-modulus calculation.

**3.7 Superstructure Decks**

Superstructure decks which are comparatively short or which are not designed as the strength deck (see 3-2-2/3.7 and 3-2-3/3.3) are to comply with the requirements of 3-2-11/1.3.

### 3.9 Deck Transitions

Where the effective areas in the same deck change, as in way of partial superstructures or over discontinuous decks, care is to be taken to extend the heavier plating well into the section of the vessel in which the lesser requirements apply, to obtain a good transition from one arrangement to the other. Partial decks within the hull are to be tapered off to the shell by means of long brackets. Where effective decks change in level, the change is to be accomplished by a gradually sloping section or the deck material at each level is to be effectively overlapped and thoroughly tied together by diaphragms, webs, brackets, etc., in such manner as will compensate for the discontinuity of the structure. At the ends of partial superstructures, the arrangements are to be as described in 3-2-2/11.

### 3.11 Deck Plating

Deck plating is to be of not less thickness than is required for purposes of longitudinal hull girder strength. The thickness of the stringer plate is to be increased 25% in way of breaks of superstructures, but this increase need not exceed 6.5 mm (0.25 in.). This requirement may be modified where the breaks of poop or forecastle are appreciably beyond the midship  $0.5L$ . The required deck area is to be maintained throughout the amidship  $0.4L$  of the vessel and is to be suitably extended into superstructures located at or near the amidship  $0.4L$ . From these locations to the ends of the vessel, the deck area contributing to the hull girder strength may be gradually reduced in accordance with 3-2-1/11.3. Where bending moment envelope curves are used to determine the required hull girder section modulus, the foregoing requirements for deck area may be modified in accordance with 3-2-1/11.3. Where so modified, the strength deck area is to be maintained a suitable distance from superstructure breaks and is to be extended into the superstructure to provide adequate structural continuity. The thickness of the deck plating is also not to be less than given in 3-2-3/5.1.

## 5 Deck Plating (1997)

### 5.1 Thickness (1997)

The thickness of deck plating is to be not less than obtained from the equations specified in 3-2-3/Table 1.

### 5.3 Effective Lower Decks

For use as an effective lower deck in calculating the hull girder section modulus, the thickness of the plating is to be not less than obtained from 3-2-3/5.1, appropriate to the depth  $D_s$ , according to 3-2-3/Table 1. In no case is the plating to be less than obtained from I or J in 3-2-3/Table 1, as appropriate. Stringer plates of effective decks are to be connected to the shell.

### 5.5 Reinforcement at Openings (1997)

#### 5.5.1 Openings in Strength Decks

Unless otherwise specifically required, openings in the strength deck are, in general, to have a minimum corner radius of 0.125 times the width of the opening, but need not exceed a radius of 600 mm (24 in.). In other decks, the radius is to be 0.09375 times the width of the opening, but need not exceed a radius of 450 mm (18 in.). Additionally, the minimum radius in way of narrow deck transverse ligaments between adjacent hatch openings having the same width is not to be less than 150 mm (6 in.).

#### 5.5.2 Openings in Effective Decks

At the corners of hatchways or other openings in effective decks, generous radii are to be provided.

### 5.5.3 In Way of Machinery Space

In way of the machinery spaces, special attention is to be paid to the maintenance of lateral stiffness by means of webs and heavy pillars in way of deck opening and casings.

## 5.7 Platform Decks

Lower decks, which are not considered to be effective decks for longitudinal strength, are termed platform decks. The plating thickness is not to be less than obtained from *Decks I or J* of 3-2-3/Table 1, as appropriate.

## 5.9 Superstructure Decks

See 3-2-11/1.3.

## 5.11 Decks Over Tanks

For decks over tanks see 3-2-10/3.5.

## 5.13 Watertight Flats

The thickness of watertight flats over tunnels, or watertight flats forming recesses or steps in bulkheads, is to be not less than the thickness required for the plating of ordinary bulkheads at the same level, plus 1 mm (0.04 in.).

## 5.15 Retractable Tween Decks

The thickness of retractable tween deck plating is not to be less than required by equation 5 of 3-2-3/Table 2, without correction for tween deck height. Where the uniform loading,  $p$ , exceeds 18.23 kN/m<sup>2</sup> (1859 kgf/m<sup>2</sup>, 381.0 lbf/ft<sup>2</sup>), the thickness is to be increased 0.83 mm for each 7.04 kN/m<sup>2</sup> or 715 kgf/m<sup>2</sup> (0.01 in. for each 45 lbf/ft<sup>2</sup>) of excess loading and may be reduced at the same rate for lesser loading. The edges of the deck panels are to be stiffened to provide the necessary rigidity.

The beams and girders, in association with the plating to which they are attached, are to have section modulus,  $SM$ , not less than obtained from the following equation.

$$SM = kchs\ell^2 \quad \text{cm}^3 \text{ (in}^3\text{)}$$

where

$$\begin{aligned} k &= 7.8 \text{ (0.0041)} \\ c &= 0.81 \text{ for the section modulus to the flange or face bar} \\ &= 1.00 \text{ for the section modulus to the deck plating} \\ h &= p/7.04 \text{ m (} p/715 \text{ m, } p/45 \text{ ft)} \\ p &= \text{uniform loading, in kN/m}^2 \text{ (kgf/m}^2\text{, lbf/ft}^2\text{)} \\ s &= \text{spacing of the beam or girder, in m (ft)} \\ \ell &= \text{unsupported length of the beam or girder, in m (ft)} \end{aligned}$$

In general, the depth of beams and girders is not to be less than 4% of the unsupported length.

When retractable decks are intended for the operation or stowage of vehicles having rubber tires, the thickness of the deck plating is to be not less than required by 3-2-15/13.7. The retractable decks are to be secured against movement and effectively supported by the hull structure.

### 5.17 Wheel Loading

Where provision is to be made for the operation or stowage of vehicles having rubber tires, and after all other requirements are met, the thickness of the plating of an effective lower deck (see 3-2-3/5.3) is not to be less than obtained from the following equation:

$$t = kKn\sqrt{CW} \text{ mm (in.)}$$

where

- $k$  = 8.05 (25.2, 1.0)
- $K$  = as obtained from 3-2-3/Figure 1
- $n$  = 1.0 where  $\ell/s \geq 2.0$  and 0.85 where  $\ell/s = 1.0$ , for intermediate values of  $\ell/s$ ,  $n$  is to be obtained by interpolation
- $C$  = 1.5 for wheel loads of vehicles stowed at sea and 1.1 for vehicles operating in port
- $W$  = static wheel load, in kN (tf, Ltf)
- $a$  = the wheel imprint dimension, in mm (in.), parallel to the longer edge,  $\ell$ , of the plate panel, and in general the larger wheel imprint dimension
- $b$  = the wheel imprint dimension, in mm (in.), perpendicular to the longer edge,  $\ell$ , of the plate panel, and in general the lesser wheel imprint dimension
- $s$  = the spacing of deck beams or deck longitudinals, in mm (in.)
- $\ell$  = the length of the plate panel, in mm (in.)

For wheel loading, the strength deck plating thickness is not to be less than 110% of that required by the above equation, and platform deck plating thickness is not to be less than 90% of that required by the above equation.

Where the wheels are close together, special consideration will be given to the use of a combined imprint and load. Where the intended operation is such that only the larger dimension of the wheel imprint is perpendicular to the longer edge of the plate panel, then  $b$  above may be taken as the larger wheel imprint dimension, in which case  $a$  is to be the lesser dimension.

**TABLE 1**  
**Applicable Thickness Equations (1997)**

<i>Decks</i>	<i>Minimum Thickness Equation in Table 2</i>
A. Strength Deck Outside Line of Openings	
1. With Transverse Beams	1a and 1b <sup>(note 1)</sup>
2. With Longitudinal Beams	2a and 2b <sup>(note 1)</sup>
B. Exposed Strength Deck within Line of Openings	3 <sup>(note 2)</sup>
C. Enclosed Strength Deck within Line of Openings	5
D. Effective Lower Decks	
1. Second Deck:	
a. $D_S > 15.2$ m (50 ft)	1a
b. $15.2$ m (50 ft) $\geq D_S \geq 12.8$ m (42 ft)	2a
c. $D_S < 12.8$ m (42 ft)	3
2. Third Deck:	
a. $D_S > 17.7$ m (58 ft)	1a
b. $17.7$ m (58 ft) $\geq D_S \geq 13.4$ m (44 ft)	2a
c. $13.4$ m (44 ft) $\geq D_S \geq 9.8$ m (32 ft)	3
d. $D_S < 9.8$ m (32 ft)	4
E. Exposed Forecastle Decks	
1. $L > 122$ m (400 ft)	2a
2. $L \leq 122$ m (400 ft)	3
F. Exposed Poop Decks	
1. $L > 100$ m (330 ft)	3
2. $L \leq 100$ m (330 ft)	5
G. Exposed Bridge Deck	4
H. Long Deckhouse Top	5
I. Platform Decks in Enclosed Cargo Spaces	6 <sup>(note 3)</sup>
J. Platform Decks in Enclosed Accommodation Spaces	7 <sup>(note 3)</sup>

*Notes:*

- 1 In small vessels where the required area is relatively small, it may be disposed in the stringer and alongside openings in plating of not less thickness than obtained from the equations in 1a and 1b; in such cases the remainder of the plating may be obtained from the equation in 5.
- 2 Equation 3 applies amidships. At the forward and aft ends, plating is to be as required for exposed forecastle and poop deck.
- 3 Where the platform decks are subjected to hull girder bending, special consideration is to be given to the structural stability of deck supporting members.

**TABLE 2**  
**Minimum Thickness Equations (1977)**

Equation Number	Equation
1a (notes 1,2)	$t = 0.01s_b + 2.3 \text{ mm}$ for $s_b \leq 760 \text{ mm}$ $t = 0.0066s_b + 4.9 \text{ mm}$ for $s_b > 760 \text{ mm}$ $t = 0.01s_b + 0.09 \text{ in.}$ for $s_b \leq 30 \text{ in.}$ $t = 0.0066s_b + 0.192 \text{ in.}$ for $s_b > 30 \text{ in.}$
1b (notes 1,3)	$t = \frac{s_b(L + 45.73)}{25L + 6082} \text{ mm}$ $t = \frac{s_b(L + 150)}{25L + 19950} \text{ in.}$
2a (notes 1,2)	$t = 0.009s_b + 2.4 \text{ mm}$ for $s_b \leq 760 \text{ mm}$ $t = 0.006s_b + 4.7 \text{ mm}$ for $s_b > 760 \text{ mm}$ $t = 0.009s_b + 0.095 \text{ in.}$ for $s_b \leq 30 \text{ in.}$ $t = 0.006s_b + 0.185 \text{ in.}$ for $s_b > 30 \text{ in.}$
2b (notes 1,3)	$t = \frac{s_b(L + 48.76)}{26L + 8681} \text{ mm}$ for $L \leq 183 \text{ m}$ $t = \frac{24.38s_b}{1615.4 - 1.1L} \text{ mm}$ for $183 < L \leq 427 \text{ m}$ $t = \frac{s_b(L + 160)}{26L + 28482} \text{ in.}$ for $L \leq 600 \text{ ft}$ $t = \frac{80s_b}{5300 - 1.1L} \text{ in.}$ for $600 < L \leq 1400 \text{ ft}$
3	$t = 0.01s_b + 0.9 \text{ mm}$ for $s_b \leq 760 \text{ mm}$ $t = 0.0067s_b + 3.4 \text{ mm}$ for $s_b > 760 \text{ mm}$ $t = 0.01s_b + 0.035 \text{ in.}$ for $s_b \leq 30 \text{ in.}$ $t = 0.0067s_b + 0.134 \text{ in.}$ for $s_b > 30 \text{ in.}$
4	$t = 0.01s_b + 0.25 \text{ mm}$ for $s_b \leq 760 \text{ mm}$ $t = 0.0043s_b + 4.6 \text{ mm}$ for $s_b > 760 \text{ mm}$ $t = 0.01s_b + 0.01 \text{ in.}$ for $s_b \leq 30 \text{ in.}$ $t = 0.0043s_b + 0.181 \text{ in.}$ for $s_b > 30 \text{ in.}$
5	$t = 0.009s_b + 0.8 \text{ mm}$ for $s_b \leq 760 \text{ mm}$ $t = 0.0039s_b + 4.3 \text{ mm}$ for $s_b > 760 \text{ mm}$ $t = 0.009s_b + 0.032 \text{ in.}$ for $s_b \leq 30 \text{ in.}$ $t = 0.0039s_b + 0.17 \text{ in.}$ for $s_b > 30 \text{ in.}$



**TABLE 2 (continued)**  
**Minimum Thickness Equations (1977)**

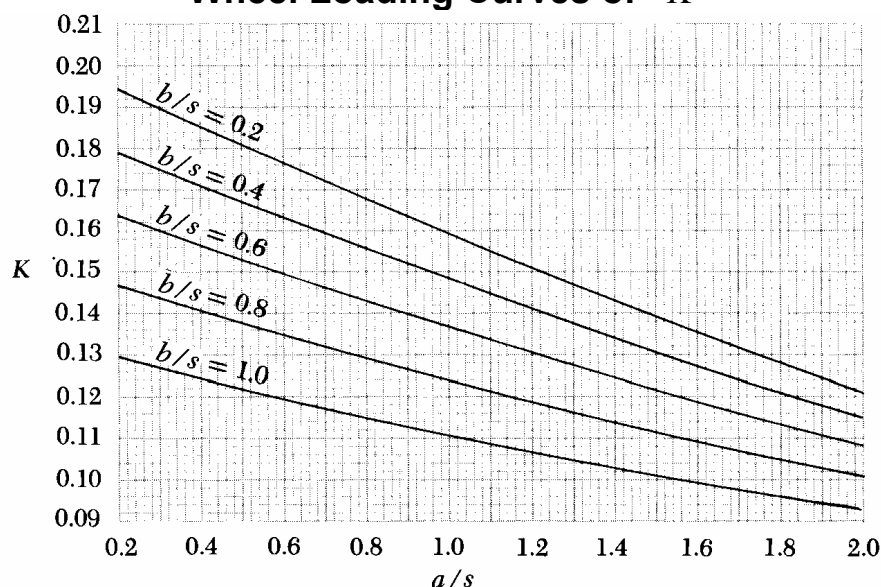
6	$t = Ks_b \sqrt{h} + a$ mm (in.) but not less than 5.0 mm (0.20 in.) $K = 0.00394$ (0.00218) $a = 1.5$ mm (0.06 in.) $h$ = tween deck height in m (ft) When a design load is specified, $h$ is to be taken as $p/n$ where $p$ is the specified design load in $\text{kN/m}^2$ ( $\text{kgf/m}^2$ , $\text{lb/ft}^2$ ) and $n$ is defined as 7.05 (715, 45)
7	$t = 0.0058s_b + 1.0$ mm $t = 0.0058s_b + 0.04$ in. but not less than 4.5 mm (0.18 in.)

$L$  = scantling length of the vessel as defined in 3-1-1/3.1 in m (ft)       $s_b$  = spacing of deck beams, in mm (in.)

Notes:

- 1 Within steel superstructures or deckhouse, the plating thickness may be reduced by 1 mm (0.04 in.).
- 2 To extend over  $0.8L$  amidships, beyond which the thickness forward and aft is not to be less than required for forecastle and poop deck plating respectively.
- 3 To extend over  $0.4L$  amidships and tapered beyond in a manner the same as in 3-2-1/11.3. Vessels designed on still water bending moment envelope curves will be specially considered.

**FIGURE 1**  
**Wheel Loading Curves of “K”**



## 7 Higher-strength Material

### 7.1 Thickness

In general, proposed applications of higher-strength material for decks are to be accompanied by submission of calculations in support of adequate strength against buckling. Care is to be exercised to avoid the adoption of reduced thickness of material such as might be subject to damage during normal operation. The thickness of deck plating for longitudinally framed decks, where constructed of higher-strength material, is to be not less than required for longitudinal strength, nor is it to be less than obtained from the following equation.

$$t_{hts} = (t_{ms} - C)Q + C \quad \text{mm (in.)}$$

where

$t_{ms}$  = thickness of ordinary-strength steel, in mm (in.), as required by the Rules

$C$  = 4.3 mm (0.17 in.) for exposed deck plating

$Q$  = is as defined in 3-2-1/5.5

The thickness  $t_{hts}$  is also to be determined from the above equation using the  $t_{ms}$  as obtained from 3-2-3/Table 2, equation 2b, or 5-2-2/5.1.2, with a factor of  $0.92/\sqrt{Q}$  in lieu of  $Q$ . The factor  $0.92/\sqrt{Q}$  is not to be less than 1.00.

Where the deck plating is transversely framed, or where the Rules do not provide a specific thickness for the deck plating, the thickness of the higher-strength material will be specially considered, taking into consideration the size of the vessel, intended service and the foregoing Rule requirements.

### 7.3 Wheel Loading

Where decks or flats are constructed of higher-strength material and provision is made for the operation or stowage of vehicles having rubber tires, the thickness of plating is to be not less than obtained from the following equation:

$$t_{hts} = t_{ms} \sqrt{M/Y} \quad \text{mm (in.)}$$

where

$t_{ms}$  = thickness of ordinary-strength steel, as obtained from 3-2-3/5.15

$Y$  = as defined in 3-2-9/5.1

$M$  = 235 (24, 34000)

## 9 Deck Covering Compositions

Deck covering compositions are to be of materials which are not destructive to steel, or they are to be effectively insulated from the steel by a noncorrosive protective covering. Samples may be taken by the Surveyor from the composition while it is being laid, in which case the samples are to be subject to independent analysis at the manufacturer's expense. The steel plating is to be thoroughly cleaned with alkaline solution before the composition is laid. Large areas of deck are to be divided by cabin sills, angles, etc., and unless otherwise approved, holdfasts are to be fitted not more than 915 mm (3 ft) apart. Deck coverings within accommodation spaces on the decks forming the crown of machinery and cargo spaces are to be of a type that will not ignite readily.

## PART

# 3

## CHAPTER 2 Hull Structures and Arrangements

### SECTION 4 Bottom Structures

#### 1 Double Bottoms

##### 1.1 General

Double bottoms are to be fitted fore and aft between the peaks, or as near thereto as practicable, in vessels of ordinary design other than tankers. Where, for special reasons, it may be desired to omit the inner bottom, the arrangements are to be clearly indicated on the plans when first submitted for approval. A double bottom need not be fitted in way of deep tanks, provided the safety of the vessel in the event of bottom damage is not thereby impaired. It is recommended that the double bottom be arranged to protect the bilges as much as possible and that it be extended to the sides of the vessel.

Shell longitudinals and frames in way of deep tanks are to have not less strength than is required by 3-2-10/3.3 for stiffeners on deep tank bulkheads. For bottom shell longitudinals bounding tanks having normal tank/air vent configurations in order to avoid accidental overpressure, the head “*h*” need not be greater than the distance from the longitudinal under consideration to the deck at side. In the case of unusual configurations or where the tanks are intended to carry liquids having a specific gravity equal to or greater than 1.05 t/m<sup>3</sup>, “*h*” should be in accordance with 3-2-10/3.3.

##### 1.3 Testing

Requirements for testing are contained in Part 3, Chapter 7.

#### 3 Center and Side Girders

##### 3.1 Center Girders (1997)

A center girder is to extend as far forward and aft as practicable. The plates are to be continuous within the amidship 0.75*L*; elsewhere, they may be intercostal between the floors. Manholes may be cut in every frame space outside the amidship 0.75*L*. Elsewhere, the minimum practical number of manholes for adequate access and ventilation may be provided, but the depth of the manholes is not to exceed one-third the depth of the center girder. Compensation for the manholes within the amidship 0.75*L* is to be provided.

##### 3.1.1 General (1999)

Center girder plates are to be of the thickness and depths given by the following equations, between the peak bulkheads. In peaks, the center girder plates are to be of the thickness of the peak floors. Where longitudinal framing is adopted, the center girder plate is to be suitably stiffened between floors, and docking brackets are to be provided in accordance with 3-2-4/3.7.

Where special arrangements, such as double skins or lower wing tanks, effectively reduce the unsupported breadth of the double bottom, the depth of the center girder may be reduced by substituting for  $B$ , the distance between the sloping plating of wing tanks at the inner bottom plating level, or the distance between the inner skins. Where the distance is less than  $0.9B$ , an engineering analysis of the double bottom structure may be required. Where the length of the cargo hold is greater than  $1.2B$ , or where the vessel is intended to carry heavy cargoes, particularly in alternate holds, the thickness and depth of center girder plates are to be specially considered.

3.1.1(a) *Thickness Amidships*

$$t = 56L \cdot 10^{-3} + 5.5 \text{ mm} \quad \text{for } L \leq 427 \text{ m}$$

$$t = 67L \cdot 10^{-5} + 0.22 \text{ in.} \quad \text{for } L \leq 1400 \text{ ft}$$

3.1.1(b) *Thickness at Ends*

85% of the thickness required amidships

3.1.1(c) *Depth*

$$d_{DB} = 32B + 190\sqrt{d} \text{ mm} \quad \text{for } L \leq 427 \text{ m}$$

$$d_{DB} = 0.384B + 4.13\sqrt{d} \text{ in.} \quad \text{for } L \leq 1400 \text{ ft}$$

where

- $t$  = thickness of plating, in mm (in.)
- $L$  = length of vessel, as defined in 3-1-1/3.1, in m (ft)
- $d_{DB}$  = depth of double bottom, in mm (in.)
- $d$  = molded draft of vessel, as defined in 3-1-1/9, in m (ft)
- $B$  = breadth of vessel, as defined in 3-1-1/5, in m (ft)

**3.3 Pipe Tunnels** (*Note: An alternative arrangement of center girders*)

A pipe tunnel, or tunnels, may be substituted for the center girder provided that the thickness of the sides of the pipe tunnel(s) is not less than is required for tank-end floors. The construction arrangement and details of pipe tunnels are to be clearly shown on the plans submitted for approval.

**3.5 Docking Brackets** (*Note: Not only for center girder but also for side girders*) (1999)

Docking brackets are to be provided on the center girder where the spacing of the floors exceeds 2.28 m (7.5 ft), unless calculations are submitted to verify that the girder provides sufficient stiffness and strength for docking loads. Where the docking arrangement is such that the side girders or bulkheads are subject to docking loads, such arrangement is to be indicated on the submitted structural plan, and docking brackets are to be fitted on those members where the spacing of floors exceeds the foregoing limit.

**3.7 Side Girders**

Amidships and aft, side girders of the thickness obtained from the equation of 3-2-4/5 are to be so arranged that the distance from the center girder to the first side girder, the distance between the girders, and the distance from the outboard girder to the center of the margin plate does not exceed 4.57 m (15 ft). At the fore end, they are to be arranged as required by 3-2-4/13.5 or 3-2-4/13.7, as appropriate. Additional full or half-depth girders are to be fitted beneath the inner bottom as required in way of machinery and thrust seatings and beneath wide-spaced pillars. Where the bottom and inner bottom are longitudinally framed, this requirement may be modified.

## 5 Solid Floors (1997)

### 5.1 General (2001)

Solid floors (see 3-2-4/Figure 1) of the thickness obtained from the following equations (and 3-2-4/5.5, where applicable), are to be fitted on every frame under machinery and transverse boiler bearers, under the outer ends of bulkhead stiffener brackets and at the forward end (see 3-2-4/13.5 or 3-2-4/13.7, as appropriate). Elsewhere, they may have a maximum spacing of 3.66 m (12 ft) in association with intermediate open floors (see 3-2-4/7), or longitudinal framing of the bottom or inner bottom plating. With the latter, the floors are to have stiffeners at each longitudinal, or an equivalent arrangement is to be provided. Where floors are fitted on every frame, the thickness need not exceed 14.0 mm (0.55 in.), provided the buckling strength is proven adequate (see 5-1-A2/3, 5-3-A2/3 or 5-5-A2/3, as appropriate, where  $t_n = 12.5$  mm (0.49 in.) in FOT or 12.0 mm (0.47 in.) for others). Where boilers are mounted on the tank top, the floors and intercostals in way of the boilers are to have an additional 1.5 mm (0.06 in.) added to their thickness after all other requirements have been satisfied.

$$t = 0.036L + 4.7 + c \text{ mm} \quad \text{for } L \leq 427 \text{ m}$$

$$t = 0.00043L + 0.185 + c \text{ in.} \quad \text{for } L \leq 1400 \text{ ft}$$

where

- $t$  = thickness, in mm (in.)
- $L$  = length of vessel, as defined in 3-1-1/3.1, in m (ft)
- $c$  = 1.5 mm (0.06 in.) for floors where the bottom shell and inner bottom are longitudinally framed
- = 0 mm (0 in.) for side girders and brackets, and for floors where the bottom shell and inner bottom are transversely framed

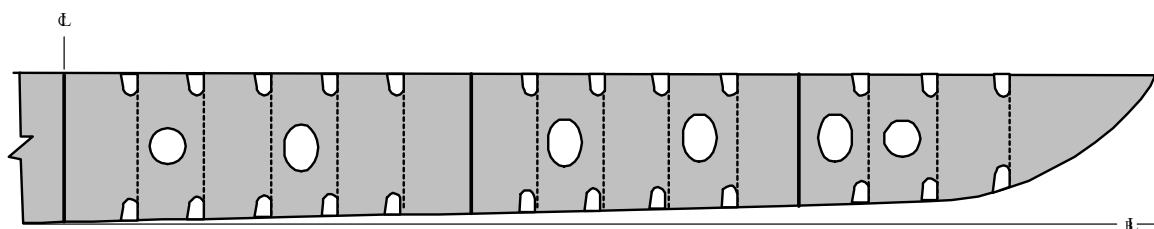
### 5.3 Tank-end Floors (1997)

Tank-end floor thickness is to be not less than required for deep tank bulkhead plating or 3-2-4/5.1, whichever is greater.

### 5.5 Floor Stiffeners

Stiffeners spaced not more than 1.53 m (5 ft) apart are to be fitted on every solid floor. Where the depth of the double bottom exceeds 0.915 m (3 ft), stiffeners on tank-end floors are to be of the sizes required for stiffeners on deep-tank bulkheads, and the spacing is not to exceed 915 mm (36 in.). Stiffeners may be omitted on non-tight floors with transverse framing, provided the thickness of the floor plate is increased 10% above the thickness obtained from 3-2-4/5.1.

**FIGURE 1**  
**Double-bottom Solid Floors**



## 7 Open Floors

### 7.1 General

Where solid floors are not fitted on every frame, as permitted 3-2-4/5.1, open floors are to be fitted at each frame between the solid floors.

### 7.3 Frames and Reverse Frames

Each frame and reverse frame similar to that shown in 3-2-4/Figure 2, in association with the plating to which it is attached, is to have a section modulus  $SM$  as obtained from the following equation:

$$SM = 7.8chs\ell^2 \text{ cm}^3$$

$$SM = 0.0041chs\ell^2 \text{ in}^3$$

where

$s$  = spacing of frames, in m (ft)

$c$  = 1.0 without struts

= 0.5 with struts in accordance with 3-2-4/7.7

$h$  = distance, in m (ft), from the keel to the summer load line ( $d$  as defined in 3-1-1/9), or two-thirds of the distance from the keel to the bulkhead or freeboard deck ( $0.66D$ ), whichever is greater. In the case of reverse frames without struts, the distance may be measured from the top of the double bottom.

$\ell$  = the greatest distance, in m (ft), between the connecting brackets or intercostals, as shown in 3-2-4/Figure 2. Where effective struts are fitted and the tank top is intended to be uniformly loaded with cargo,  $\ell$  may be taken as 85% of the distance between supports, as determined above.

### 7.5 Center and Side Brackets

Center and side brackets are to overlap the frames and reverse frames for a distance equal to  $0.05B$  (see 3-2-4/Figure 2); they are to be of the thickness required for solid floors in the same location and are to be flanged or stiffened on their outer edges.

### 7.7 Struts

The permissible load  $W_a$  for struts is to be determined in accordance with 3-2-8/3.1. The calculated load  $W$  is to be determined by:

$$W = nphs \text{ kN (tf, Ltf)}$$

where

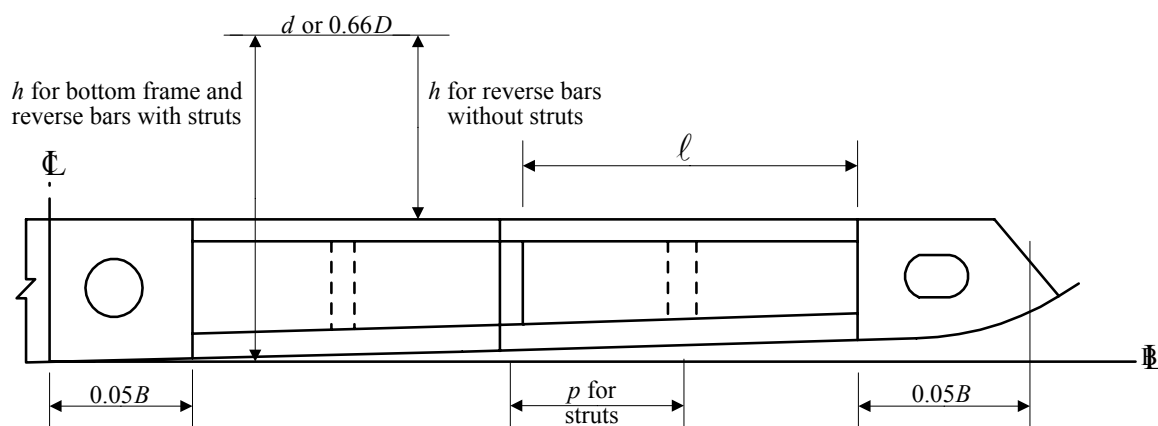
$n$  = 10.5 (1.07, 0.03)

$p$  = distance, in m (ft), between center of the struts.

$s, h$  are as defined in 3-2-4/7.3.

Struts are to be positioned so as to divide the span into approximately equal intervals.

**FIGURE 2**  
**Double-bottom Open Floors**



## 9 Inner-bottom Plating

### 9.1 Inner-bottom Plating Thickness (1997)

Inner-bottom plating thickness is not to be less than obtained from the following equation or as required by 3-2-10/3.5, or by 3-2-1/19, whichever is the greatest:

$$t = 37.0L \cdot 10^{-3} + 0.009s - c \text{ mm} \quad \text{for } L \leq 427 \text{ m}$$

$$t = 44.4L \cdot 10^{-5} + 0.009s - c \text{ in.} \quad \text{for } L \leq 1400 \text{ ft}$$

where

$L$  = scantling length of vessel, as defined in 3-1-1/3.1, in m (ft)

$s$  = frame spacing, in mm (in.)

$c$  = 0.5 mm (0.02 in.) with transverse framing

= 1.5 mm (0.06 in.) with longitudinal framing

Where close ceiling, as defined in 3-2-18/1, is not fitted on the inner bottom in way of hatchways, the thickness  $t$ , as determined above, is to be increased by 2.0 mm (0.08 in.), except in holds designated exclusively for the carriage of containers on the inner bottom.

### 9.3 Center Strakes

Center strakes are to have a thickness determined from 3-2-4/9.1; in way of pipe tunnels, the thickness may require to be suitably increased.

### 9.5 Under Boilers

Under boilers, there is to be a clear space of at least 460 mm (18 in.). Where the clear space is necessarily less, the thickness of the plating is to be increased as may be required.

### 9.7 In Way of Engine Bed Plates or Thrust Blocks

In way of engine bed plates or thrust blocks which are bolted directly to the inner bottom, the thickness of the inner bottom plating is to be at least 19.0 mm (0.75 in.). This thickness may be required to be increased according to the size and power of the engine(s). Holding-down bolts are to pass through angle flanges of sufficient breadth to take the nuts.

## 9.9 Margin Plates (1997)

Where margin plates are approximately vertical, the plates amidships are to extend for the full depth of the double bottom with a thickness not less than obtained from the equation in 3-2-4/9.1 plus 2.0 mm (0.08 in.). Where approximately horizontal, margin plates may be of the thickness required for tank-top plating at that location.

## 9.11 Recommendations Where Cargo is Handled by Grabs

For vessels regularly engaged in trades where the cargo is handled by grabs, or similar mechanical appliances, it is recommended that flush inner-bottom plating be adopted throughout the cargo space, and that the plating requirements of 3-2-4/9.1 be suitably increased, but the increase need not exceed 5.0 mm (0.20 in.) It is also recommended that the minimum thickness be not less than 12.5 mm with 610 mm (0.50 in. with 24 in.) frame spacing and 19.0 mm with 915 mm (0.74 in. with 36 in.) frame spacing, and the thickness for intermediate frame spacing is to be obtained by linear interpolation.

## 9.13 Wheel Loading

Where provision is to be made for the operation or stowage of vehicles having rubber tires, and after all other requirements are met, the thickness of the inner bottom plating is to be not less than obtained from 3-2-3/5.15.

# 11 Bottom and Inner-bottom Longitudinals

## 11.1 General

Bottom and inner-bottom longitudinals are to be continuous or attached at their ends to effectively develop their sectional area and their resistance to bending.

## 11.3 Bottom Longitudinals

Each bottom longitudinal frame similar to that shown in 3-2-4/Figure 1, in association with the plating to which it is attached, is to have a section modulus  $SM$  not less than that obtained from the following equation:

$$SM = 7.8 chs\ell^2 \text{ cm}^3$$

$$SM = 0.0041 chs\ell^2 \text{ in}^3$$

where

$$c = 1.3 \text{ without struts}$$

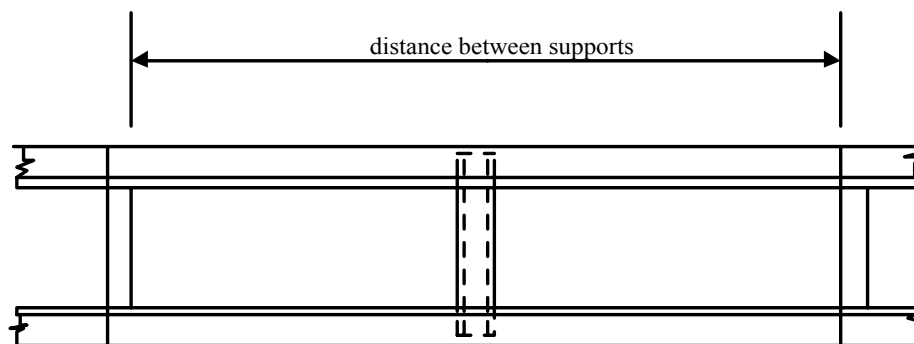
$$= 0.715 \text{ with effective struts}$$

$$h = \text{distance, in m (ft), from the keel to the load line, or two-thirds of the distance to the bulkhead or freeboard deck, whichever is the greater.}$$

$$s = \text{spacing of longitudinals, in m (ft)}$$

$$\ell = \text{distance, in m (ft), between the supports, but is not to be taken as less than 1.83 m (6 ft) without struts or 2.44 m (8 ft) with struts. Where effective struts are fitted and the tank top is intended to be uniformly loaded with cargo, } \ell \text{ may be taken as 81\% of the distance between supports subject to above minimum.}$$





The section modulus  $SM$  of the bottom longitudinals may be obtained from the above equations multiplied by the factor  $R_\ell$  where,

- i) The bottom hull girder section modulus  $SM_A$  is greater than required by 3-2-1/3.7.1, at least throughout  $0.4L$  amidships,
- ii) Still-water bending moment calculations are submitted, and
- iii) Adequate buckling strength is maintained.

$$R_\ell = n / [n + f_p (1 - SM_R / SM_A)] \quad \text{but is not to be taken less than 0.69}$$

where

- $n = 8.278 (0.852, 5.36)$
- $f_p =$  nominal permissible bending stress, as given in 3-2-1/3.7.1
- $SM_R =$  hull girder section modulus required by 3-2-1/3.7.1, in  $\text{cm}^2\text{-m}$  ( $\text{in}^2\text{-ft}$ )
- $SM_A =$  bottom hull girder section modulus, in  $\text{cm}^2\text{-m}$  ( $\text{in}^2\text{-ft}$ ), with the longitudinals modified as permitted above.

Bottom longitudinals, with this modified section modulus are to meet all other Rule requirements including side longitudinals in 3-2-5/3.17.

### 11.5 Inner-bottom Longitudinals

Inner-bottom longitudinals are to have values of  $SM$  at least 85% of that required for the bottom longitudinals.

## 13 Fore-end Strengthening

### 13.1 General

Where the heavy weather ballast draft forward is less than  $0.04L$  m (ft), strengthening of the flat of bottom forward is to be in accordance with 3-2-4/13.3, 3-2-4/13.5, 3-2-4/13.7 and 3-2-2/5.5. Information on the heavy weather ballast draft forward used for the required fore-end strengthening is to be furnished to the master for guidance. The heavy weather ballast draft is also to be indicated on the shell expansion plan.

### 13.3 Extent of Strengthening

The flat of bottom forward is forward of the locations indicated in 3-2-4/Table 1. For intermediate values of  $C_b$ , the locations are to be obtained by interpolation. Aft of these locations, a suitable transition is to be obtained between the increased scantlings and structural arrangements of the flat of bottom forward and the structure aft of the locations given in 3-2-4/Table 1.

### 13.5 Longitudinal Framing

When longitudinal framing is used for the bottom and inner bottom, longitudinals and side girders are to be continued as far forward as practicable at not more than their amidship spacing. The section modulus of flat of bottom longitudinals forward of the location indicated in 3-2-4/Table 1 is to be not less than required by the following equation, nor less than required by 3-2-4/11.3.

$$SM = 8.47(0.005 L_1^2 - 1.3 d_f^2) s \ell^2 / d_f \text{ cm}^3$$

$$SM = 0.0044(0.005 L_1^2 - 1.3 d_f^2) s \ell^2 / d_f \text{ in}^3$$

where

- $d_f$  = heavy weather ballast draft at the forward perpendicular, in m (ft)
- =  $d_f \times 214/L$  m ( $d_f \times 702/L$  ft), where  $L > 214$  m (702 ft)
- $L_1$  = length of vessel, as defined in 3-1-1/3.1, in m (ft), but need not be taken as greater than 214 m (702 ft)
- $L$  = length of vessel, as defined in 3-1-1/3.1, in m (ft)
- $s$  = spacing of longitudinals, in m (ft)
- $\ell$  = distance between floors, in m (ft)

The spacing of floors in the forward  $0.25L$  is not to be greater than that given in 3-2-4/Table 2 nor greater than the spacing amidships.

### 13.7 Transverse Framing

Where the heavy weather ballast draft forward is less than  $0.04L$  m (ft), solid floors are to be fitted on every frame, and additional full-depth and half-depth side girders are to be introduced so that the spacing of full-depth girders forward of the location in 3-2-4/Table 1 does not exceed 2.13 m (7 ft) and that the spacing of alternating half and full-depth girders forward of the location in 3-2-4/Table 1 does not exceed 1.07 m (3.5 ft). Where the heavy weather ballast draft forward is  $0.04L$  m (ft) or more, the arrangement of solid floors and side girders may be in accordance with 3-2-4/3.9 and 3-2-4/5.

**TABLE 1**

$C_b$	Location Forward of Amidships
0.6 or less	$0.25L$
0.8 or more	$0.30L$

$C_b$  is the block coefficient as defined in 3-1-1/11.3.

**TABLE 2**  
**Spacing of Floors**

$d_f^{(1,3)}$	$C_b$	<i>From 0.25L to 0.3L from amidships</i>	<i>Forward of 0.3L from amidships</i>
0.02L and less	0.60 or less	$3s^{(2)}$	$2s^{(2)}$
	greater than 0.60	$3s^{(2)}$	$3s^{(2)}$
0.035L	all values	$3s^{(2)}$	$3s^{(2)}$
0.04L and more	all values	As required elsewhere in the Rules	

- 1  $d_f$  is the heavy weather ballast draft, in m (ft), at the forward perpendicular and  $C_b$  is the block coefficient at the summer load waterline, based on  $L$ , as defined in 3-1-1/3.1.
- 2  $s$  is the spacing of transverse side frames, in m (ft), or  $S$  in 3-2-5/1.7, where side shell is longitudinally framed.
- 3 For values of  $d_f$  between 0.02L, 0.035L and 0.04L m (ft), the floor spacing may be obtained by interpolation.

## 15 Higher-strength Materials

### 15.1 General

In general, applications of higher-strength materials for bottom structures are to meet the requirements of this section, but may be modified as permitted by the following paragraphs. Care is to be exercised to avoid the adoption of a reduced thickness of material such as might be subject to damage during normal operation, and calculations are to be submitted to show adequate provision against buckling. Longitudinal framing members are to be of essentially the same material as the plating they support.

### 15.3 Inner-bottom Plating

Inner-bottom plating, where constructed of higher-strength material and where longitudinally framed, is to be not less in thickness than required by 3-2-4/9.1 or 3-2-10/3.5, as modified by the following equation.

$$t_{hts} = [t_{ms} - C] [(Q + 2\sqrt{Q})/3] + C$$

where

- $t_{hts}$  = thickness of higher-strength material, in mm (in.)
- $t_{ms}$  = thickness of mild steel, as required by 3-2-4/9.1 or 3-2-10/3.5, in mm (in.), increased where required by 3-2-4/9.1 for no ceiling
- $C$  = 3 mm (0.12 in.)  
 = 5 mm (0.20 in.) where the plating is required by 3-2-4/9.1 to be increased for no ceiling
- $Q$  = as defined in 3-2-1/5.5

The thickness of inner-bottom plating, where transversely framed, will be specially considered.

Where cargo is handled by grabs, or similar mechanical appliances, the recommendations of 3-2-4/9.11 are applicable to  $t_{hts}$ .

## 15.5 Bottom and Inner-bottom Longitudinals

The section modulus of bottom and inner-bottom longitudinals, where constructed of higher-strength material and in association with the higher-strength plating to which they are attached, is to be determined as indicated in 3-2-4/11.3 and 3-2-4/11.5, except that the value may be reduced by the factor  $Q$ , as defined in 3-2-1/5.5.

## 15.7 Center Girders, Side Girders, and Floors

Center girders, side girders, and floors, where constructed of higher-strength materials, generally are to comply with the requirements of 3-2-4/3 or 3-2-4/5, but may be modified, as permitted, by the following equation.

$$t_{hts} = [t_{ms} - C] [(Q + 2\sqrt{Q})/3] + C$$

where  $t_{hts}$ ,  $t_{ms}$ , and  $C$  are as defined in 3-2-4/15.3.

$Q$  is as defined in 3-2-1/5.5.

# 17 Structural Arrangements and Details

## 17.1 Structural Sea Chests

In addition to the requirements of 3-2-4/1 and 3-2-4/9, where the inner-bottom or the double-bottom structure form part of a sea chest, the thickness of the plating is to be not less than required by 3-2-2/5.1 for the shell at  $0.1L$ , where  $s$  is the maximum unsupported width of plating. The thickness need not exceed that required in 3-2-2/3 for side or bottom shell, as appropriate.

## 17.3 Drainage

Efficient arrangements are to be provided for draining water that may gather on the inner bottom. Where wells are fitted for such purpose, it is recommended that, with the exception of the after tunnel well, such wells are not to extend for more than one-half the depth of the double bottom nor to less than 460 mm (18 in.) from the shell or from the inner edge of the margin plate and are to be so arranged as to comply with 4-6-4/5. Plating forming drain wells is to be at least 2.5 mm (0.10 in.) greater than is otherwise required at that location. This requirement may be modified where corrosion-resistant material is used or special protective coatings are applied. Thick steel plates or other approved arrangements are to be provided in way of sounding pipes to prevent damage by the sounding rods.

## 17.5 Manholes and Lightening Holes

Manholes and lightening holes are to be cut in all non-tight members, except in way of widely spaced pillars, to ensure accessibility and ventilation; the proposed locations and sizes of holes are to be indicated on the plans submitted for approval. Manholes in tank tops are to be sufficient in number to secure free ventilation and ready access to all parts of the double bottom. Care is to be taken in locating the manholes to avoid the possibility of interconnection of the main subdivision compartments through the double bottom, insofar as practicable. Covers are to be of steel or equivalent material, and where no ceiling is fitted in the cargo holds, they are to be effectively protected from damage by the cargo.

## 17.7 Air and Drainage Holes

Air and drainage holes are to be cut in all parts of the structure to ensure free escape of air to the vents and free drainage to the suction pipes.

PART

**3**

CHAPTER **2 Hull Structures and Arrangements**

SECTION **5 Frames**

**1 General**

**1.1 Basic Considerations**

The required sizes and arrangements of frames are to be in accordance with this section and as shown in 3-2-5/Figure 1. The equations apply to vessels which have well-rounded lines, normal sheer and bulkhead support not less effective than that specified in Section 3-2-9. Additional stiffness will be required where bulkhead support is less effective, where sheer is excessive or where flat surface areas are abnormally large. Frames are not to have less strength than is required for bulkhead stiffeners in the same location in association with heads to the bulkhead deck, and in way of deep tanks they are not to have less strength than is required for stiffeners on deep-tank bulkheads. Framing sections are to have sufficient thickness and depth in relation to the spans between supports.

**1.3 Holes in Frames**

The calculated section modulus for frames is based upon the intact section being used. Where it is proposed to cut holes in the outstanding flanges or large openings in the webs of any frame, the net section is to be used in determining the section modulus for the frame, in association with the plating to which it is attached.

**1.5 End Connections**

At the ends of unbracketed frames, both the web and the flange are to be welded to the supporting member. At bracketed end connections, continuity of strength is to be maintained at the connection to the bracket and at the connection of the bracket to the supporting member. Welding is to be in accordance with 3-2-19/Table 1. Where longitudinal frames are not continuous at bulkheads, end connections are to effectively develop their sectional area and resistance to bending. Where a structural member is terminated, structural continuity is to be maintained by a suitable back-up structure, fitted in way of the end connection of frames, or the end connection is to be effectively extended by a bracket or flat bar to an adjacent beam, stiffener, etc.

**1.7 Standard and Cant Frame Spacing (1997)**

The standard frame spacing,  $S$ , amidships for vessels with transverse framing, may be obtained from the following equations. In vessels of fine form or high power, a closer spacing is to be considered within and adjacent to the peaks. The spacing of cant frames is not to exceed the standard frame spacing.

$$S = 2.08L + 438 \text{ mm} \quad \text{for } L \leq 270 \text{ m}$$

$$S = 1000 \text{ mm} \quad \text{for } 270 < L \leq 427 \text{ m}$$

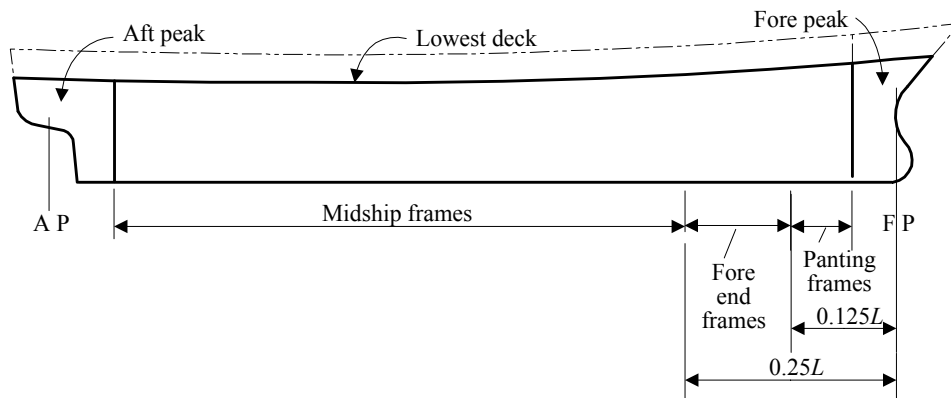
$$S = 0.025L + 17.25 \text{ in.} \quad \text{for } L \leq 890 \text{ ft}$$

$$S = 39.5 \text{ in.} \quad \text{for } 890 < L \leq 1400 \text{ ft}$$

where

$S$  = standard frame spacing, in mm (ft)  
 $L$  = scantling length of vessel, as defined in 3-1-1/3.1, in m (ft)

**FIGURE 1**  
**Zones of Framing**



### 3 Hold Frames

#### 3.1 Transverse Frames (1997)

##### 3.1.1 Strength Requirement

The section modulus  $SM$  of each transverse frame amidships and aft below the lowest deck is to be obtained from the following equation, where  $\ell$  is the span in m (ft) as shown in 3-2-5/Figure 2, 3-2-5/Figure 3, and 3-2-5/Figure 4 between the toes of brackets. The value of  $\ell$  for use with the equation is not to be less than 2.10 m (7 ft).

$$SM = s\ell^2(h + bh_1/30) (7 + 45/\ell^3) \text{ cm}^3$$

$$SM = s\ell^2(h + bh_1/100) (0.0037 + 0.8/\ell^3) \text{ in}^3$$

where

$s$  = frame spacing, in m (ft)  
 $h$  = vertical distance, in m (ft), from the middle of  $\ell$  to the load line or  $0.4\ell$ , whichever is the greater.  
 $b$  = horizontal distance, in m (ft), from the outside of the frames to the first row of deck supports

$h_1$  = vertical distance, in m (ft), from the deck at the top of the frame to the bulkhead or freeboard deck plus the height of all cargo tween-deck spaces and one-half the height of all passenger spaces above the bulkhead or freeboard deck, or plus 2.44 m (8 ft), if that be greater. Where the cargo load differs from 7.04 kN/m<sup>3</sup> (715 kgf/m<sup>3</sup>, 45 lbf/ft<sup>3</sup>) multiplied by the tween-deck height in m (ft), the height of that tween-deck is to be proportionately adjusted in calculating  $h_1$ .

### 3.1.2 Deck Longitudinals with Deep Beams

Where the decks are supported by longitudinal beams in association with wide-spaced deep transverse beams, the value of  $h_1$  for the normal frames between the deep beams may be taken as equal to zero; for the frames in way of the deep beams, the value of  $h_1$  is to be multiplied by the number of frame spaces between the deep beams.

### 3.1.3 Sizes Increased for Heavy Load

Where a frame may be subject to special heavy loads, such as may occur at the ends of deep transverse girders which in turn carry longitudinal deck girders, the section modulus is to be suitably increased in proportion to the extra load carried.

## 3.3 Raised Quarter Decks

In way of raised quarter decks,  $\ell$  is to be the corresponding midship span in way of the freeboard deck plus one-half the height of the raised quarter deck, and the other factors are to be those obtained for midship frames in way of the freeboard deck.

## 3.5 Fore-end Frames

Each fore-end frame between the amidship  $0.5L$  and the amidship  $0.75L$  is to have a section modulus obtained from 3-2-5/3.1, where  $\ell$  is to be the corresponding midship span plus one-half the sheer at  $0.125L$  from the stem; the other factors are to be those obtained for midship frames adjusted for spacing if required. Where there is no sheer, no increase in length is required. In deep tanks, the unsupported span of frames is not to exceed 3.66 m (12 ft).

## 3.7 Panting Frames

Each panting frame between the midship three-quarters length and the forepeak bulkhead in vessels which have effective panting arrangements as per 3-2-5/3.13 is to have a section modulus as obtained from 3-2-5/3.1, where  $\ell$  is to be the corresponding midship span plus the sheer in m (ft) at  $0.125L$  from the stem. In vessels having normal sheer, the other factors in 3-2-5/3.1 are to be the same as those used for midship frames, adjusted for spacing if required. Where there is no sheer, the value of  $SM$  in 3-2-5/3.1 is to be at least 25% greater than obtained for corresponding midship frames, adjusted for spacing; where the sheer is less than normal, the increase is to be proportionate. Panting frames are to have depths not less than 1/20th of the actual span.

## 3.9 Side Stringers

Where stringers are fitted in accordance with this paragraph, the  $SM$  in 3-2-5/3.1, 3-2-5/3.3, and 3-2-5/3.5 above may be reduced 20%, where  $\ell$  exceeds 2.74 m (9 ft) and the stringers are arranged so that there is not more than 2.10 m (7 ft) of unbroken span at any part of the girth of the hold framing. Stringers are to be at least as deep as the frames and are to have continuous face plates.

### 3.11 Frames with Web Frames and Side Stringers

Where frames are supported by a system of web frames and side stringers of the sizes and arrangement obtained from Section 3-2-6, the section modulus is to be determined in accordance with 3-2-5/3.1, 3-2-5/3.5, and 3-2-5/3.7, but the length  $\ell$  may be taken as the distance from the toe of the bracket to the lowest stringer plus 0.15 m (0.5 ft). The value of  $\ell$  for use with the equations is not to be less than 2.10 m (7 ft).

### 3.13 Panting Webs and Stringers

Abaft the forepeak and forward of the after peak, panting arrangements are to be provided as may be required to meet the effects of sheer and flatness of form. Web frames are to be fitted at a gradually increasing spacing aft of the forepeak bulkhead and it is recommended that the first frame abaft the forepeak bulkhead be increased in size. Narrow stringers, similar to those described in 3-2-5/3.9, are to be fitted in this area in line with the stringers in the forepeak. At the after end, where owing to the shape of the vessel, the frames have longer unsupported spans than the normal midship frames, stringers or frames of increased size may be required.

### 3.15 Hold Frame Brackets (1997)

Brackets connecting hold frames to margin plates are to be flanged (edge stiffened) and of not less thickness than the frame web thickness plus 2 mm (0.08 in.) The thickness is also not to be less than required by 3-2-9/Table 1. Where the double bottom is longitudinally framed, flanged brackets are to be fitted inside the double bottom in line with the hold frame brackets and extending to the outboard inner bottom and shell longitudinals.

### 3.17 Longitudinal Frames (1995)

The section modulus  $SM$  of each longitudinal side frame is to be not less than obtained from the following equation:

$$SM = 7.8 chs\ell^2 \text{ cm}^3$$

$$SM = 0.0041 chs\ell^2 \text{ in}^3$$

where

$s$  = spacing of longitudinal frames, in m (ft)

$c$  = 0.95

$h$  = above  $0.5D$  from the keel, the vertical distance, in m (ft), from the longitudinal frame to the bulkhead or freeboard deck, but is not to be taken as less than 2.13 m (7.0 ft).

= at and below  $0.5D$  from the keel, 0.75 times the vertical distance, in m (ft), from the longitudinal frame to the bulkhead or freeboard deck, but not less than  $0.5D$ .

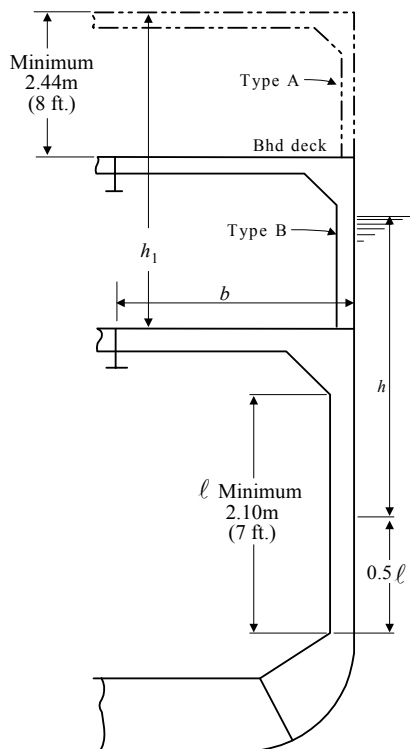
$\ell$  = the unsupported span, in m (ft)

### 3.19 Machinery Space (1997)

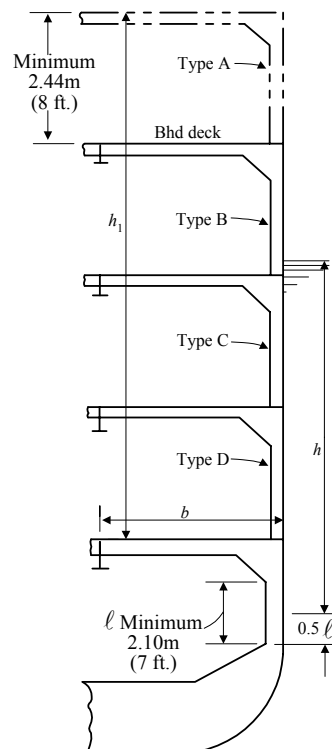
Care is to be taken to provide sufficient transverse strength and stiffness in the machinery space by means of webs and heavy pillars in way of deck openings and casings.



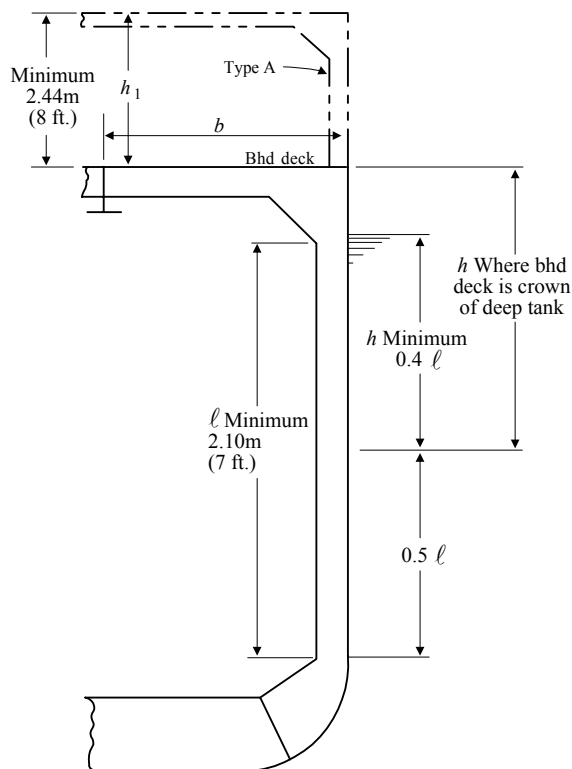
**FIGURE 2**  
**Hold Frames**



**FIGURE 3**  
**Hold Frames**



**FIGURE 4**  
**Hold Frames**



## 5 Tween-deck Frames

### 5.1 General

The size of tween-deck framing is dependent upon the standard of main framing, arrangement of bulkhead support, requirements of special loading, etc. In the design of the framing, consideration is to be given to the provision of continuity in the framing from the bottom to the top of the hull; the standard is also contingent upon the maintenance of general transverse stiffness by means of efficient partial bulkheads in line with the main hold bulkheads, or by the extension of deep frames at regular intervals to the tops of superstructures. Care is to be taken that the strength and stiffness of the framing at the ends of the vessel are proportioned to the actual unsupported length of the frame. Panting arrangements, comprised of webs and stringers, may be required in way of the forecastle side plating to meet the effects of flare.

### 5.3 Transverse Tween-deck Frames

The section modulus  $SM$  of each transverse tween-deck frame is to be obtained from the following equation:

$$SM = (7 + 45/\ell^3)s\ell^2K \text{ cm}^3$$

$$SM = (0.0037 + 0.8/\ell^3)s\ell^2K \text{ in}^3$$

where

- $\ell$  = tween deck height or unsupported span along the frame length, whichever is greater, in m (ft)
- $s$  = spacing of the frames, in m (ft)
- $K$  = factor appropriate to the length of vessel and type of tween decks, A, B, C, or D, as shown in 3-2-5/Figure 2, 3-2-5/Figure 3, and 3-2-5/Figure 4
- $L$  = length of vessel, as defined in 3-1-1/3.1, but need not be taken as greater than 305 m (1000 ft)

Type A	$K = 0.022L - 0.47$	for $L \leq 427$ m
	$K = 0.022L - 1.54$	for $L \leq 1400$ ft
Type B	$K = 0.034L - 0.56$	for $L \leq 427$ m
	$K = 0.034L - 1.84$	for $L \leq 1400$ ft
Type C	$K = 0.036L - 0.09$	for $L \leq 180$ m
	$K = 0.031L + 0.83$	for $180 < L \leq 427$ m
	$K = 0.036L - 0.29$	for $L \leq 590$ ft
Type D	$K = 0.031L + 2.8$	for $590 < L \leq 1400$ ft
	$K = 0.029L + 1.78$	for $L \leq 427$ m
	$K = 0.029L + 5.84$	for $L \leq 1400$ ft

Tween-deck frames above the bulkhead deck forward of  $0.125L$  from the stem are to be based on type B. Below the bulkhead deck, they are to be not less than required by the foregoing equations. In general, below the bulkhead deck and forward of the forepeak bulkhead, tween-deck frames are also to be not less than required by 3-2-5/7.1.

## 5.5 Longitudinal Tween-deck Frames (1995)

Longitudinal tween-deck frames are to be in accordance with 3-2-5/3.17. The section modulus of each longitudinal tween-deck frame forward of  $0.125L$  from the stem is to be not less than required by 3-2-5/5.3 for transverse frames in the same location, taking  $\ell$  as the unsupported span along the frame length. Particular attention is to be given to the buckling strength of the longitudinal tween-deck frames adjacent to the strength deck where scantling reductions are being considered for the use of higher-strength steel. See also 3-2-1/19 and Appendix 3-2-A4.

## 7 Forepeak Frames

### 7.1 General

Forepeak frames are to be efficiently connected to deep floors of not less thickness than that obtained from 3-2-4/5.1 for floors with transverse framing, but the thickness need not exceed 14.0 mm (0.56 in.), provided the stiffeners are not spaced more than 1.22 m (4 ft). The floors are to extend as high as necessary to give lateral stiffness to the structure and are to be properly stiffened on their upper edges. Care is to be taken in arranging the framing and floors to assure no wide areas of unsupported plating adjacent to the stem. Angle ties are to be fitted, as required, across the tops of the floors and across all tiers of beams or struts to prevent vertical or lateral movement. Breast hooks are to be arranged at regular intervals at and between the stringers above and below the waterline. In general, the frames above the lowest deck are to be as required by 3-2-5/7.3, but in vessels having large flare or varying sheers on the different decks, with unusually long frames, stringers and webs above the lowest deck or suitably increased frames may be required.

### 7.3 Frame Scantlings

The section modulus  $SM$  of frames is to be obtained, as follows, for three different systems of construction.

#### 7.3.1 Beams on Alternate Frames

In vessels where beams are fitted on alternate frames, in conjunction with flanged stringer plates of the sizes given in 3-2-6/9, are fitted in tiers at intervals of not more than 2.10 m (7 ft) apart, and the distance from the lowest tier to the top of the floor is not more than 1.83 m (6 ft), the section modulus  $SM$  of the peak frames are to be obtained from the following equation.

$$SM = 3.7sL - 9.0 \text{ cm}^3 \quad \text{for } L \leq 427 \text{ m}$$

$$SM = 0.021sL - 0.55 \text{ in}^3 \quad \text{for } L \leq 1400 \text{ ft}$$

where

$$s = \text{frame spacing, in m (ft)}$$

$$L = \text{length of vessel, as defined in 3-1-1/3.1, in m (ft)}$$

#### 7.3.2 Beams or Struts on Every Frame

Where beams or struts are fitted on every frame (but without stringer plates) in tiers 1.52 m (5 ft) apart, the section modulus  $SM$  of the frames is not to be less than determined by the above equation, nor is the section modulus to be less than obtained from the following equation, where  $\ell$  is the length, in m (ft), of the longest actual span of the peak frame from the toe of the lowest deck beam knee to the top of the floor.

$$SM = (0.025L - 0.44)(7 + 45/\ell^3)\ell^2 \text{ cm}^3 \quad \text{for } L \leq 427 \text{ m}$$

$$SM = (0.085L - 5)(0.0037 + 0.8/\ell^3)\ell^2 \text{ in}^3 \quad \text{for } L \leq 1400 \text{ ft}$$

where

$L$  = length of vessel, as defined in 3-1-1/3.1, in m (ft)

### 7.3.3 No Beams or Struts Fitted

Where no beams or struts are fitted, the section modulus of frames is not to be less than that determined by the equation in 3-2-5/7.3.1, nor is the section modulus to be less than twice that obtained from the equation in 3-2-5/7.3.2 in association with a length  $\ell$ , as defined in 3-2-5/7.3.2.

### 7.3.4 Struts and Beams

Struts and beams, where fitted, are generally to be equivalent to channels having an area approximately the same as the forepeak frames.

## 9 After-peak Frames

### 9.1 General

After-peak frames are to be efficiently connected to deep floors of not less thickness than obtained from 3-2-4/5.1 for floors with transverse framing, but need not exceed 14.0 mm (0.56 in.), provided the floors are suitably stiffened. The floors are to extend as high as necessary to give lateral stiffness to the structure and are to be properly stiffened with flanges. Angle ties are to be fitted across the floors and tiers of beams or struts as required to prevent vertical or lateral movement.

### 9.3 Frame Scantlings

The section modulus  $SM$  of each after-peak frame is to be obtained from the following equation, in association with deep floors, tiers of beams, stringers, or struts arranged so that there are not more than 2.44 m (8 ft) between supports at any part of the girth of the frame.

$$SM = 2.79sL - 36 \text{ cm}^3 \quad \text{for } L \leq 427 \text{ m}$$

$$SM = 0.016sL - 2.2 \text{ in}^3 \quad \text{for } L \leq 1400 \text{ ft}$$

where

$s$  = frame spacing, in m (ft)

$L$  = length of vessel, as defined in 3-1-1/3.1, in m (ft)

### 9.5 Vessels of High Power or Fine Form

For vessels of high power or fine form, a number of plate floors extending to the lowest deck or flat and suitably supported longitudinally, web frames in the tween decks or other stiffening arrangements may be required in addition to the requirements of 3-2-5/9.1 and 3-2-5/9.3.

PART

# 3

CHAPTER **2 Hull Structures and Arrangements**

SECTION **6 Web Frames and Side Stringers**

**1 General (1994)**

Web frames and, in the case of transverse framing, side stringers, similar to those shown in 3-2-6/Figure 1, where fitted in association with transverse or longitudinal frames of the sizes specified in 3-2-5/3.11 or 3-2-5/3.17, are to be of the sizes as required by this section. It is recommended that webs and stringers be spaced not more than approximately 3 m (10 ft) apart. Webs and stringers are not to have less strength than would be required for similar members on watertight bulkheads, and in way of deep tanks, they are to be at least as effective as would be required for similar members on deep-tank bulkheads. For webs in machinery spaces, see also 3-2-5/3.19.

**3 Web Frames**

**3.1 Hold Web Frames Amidships and Aft**

Each hold web frame amidships and aft is to have a section modulus  $SM$  not less than obtained from the following equation:

$$SM = 4.74cs\ell^2(h + bh_1/45K) \text{ cm}^3$$

$$SM = 0.0025cs\ell^2(h + bh_1/150K) \text{ in}^3$$

where

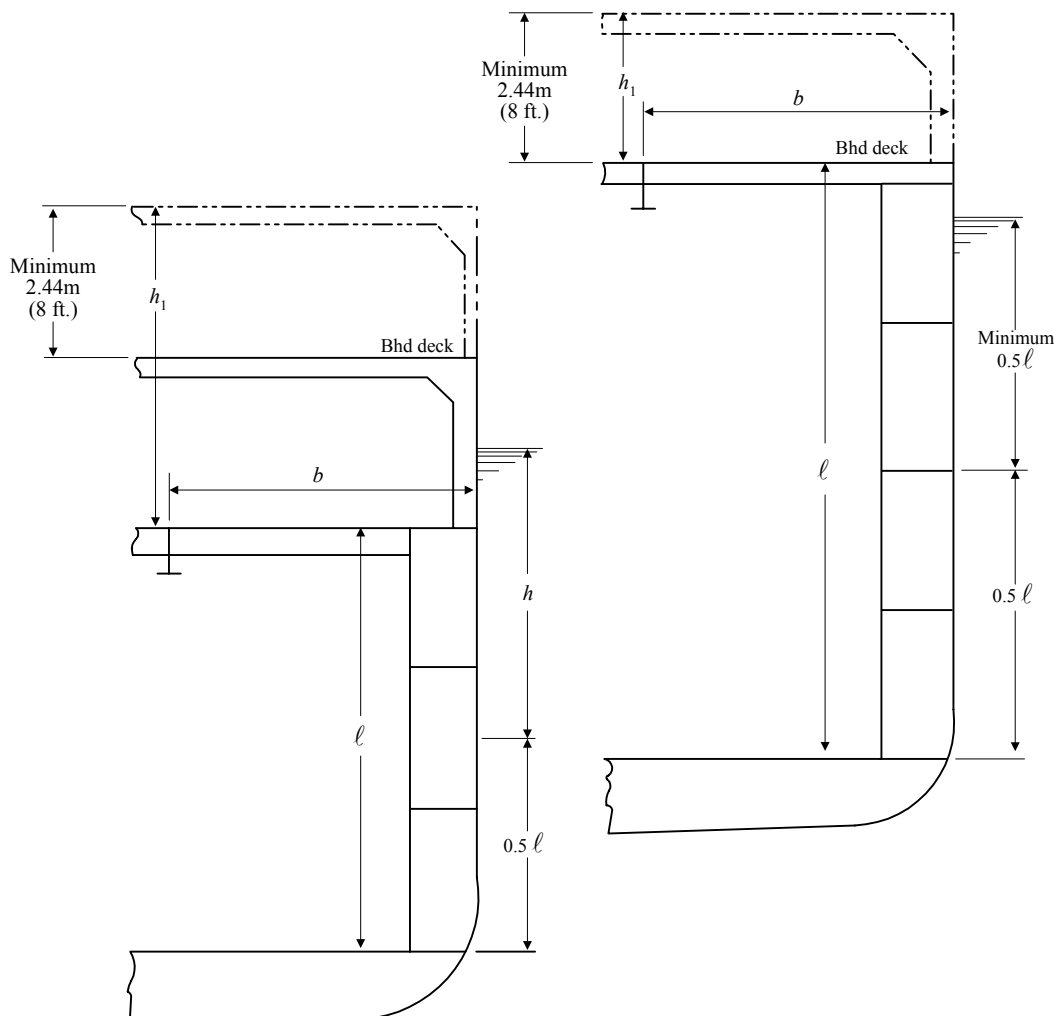
- $c$  = 1.5
- $s$  = spacing of the web frames, in m (ft)
- $\ell$  = span, in m (ft), at amidships measured from the line of the inner bottom (extended to the side of the vessel) to the deck at the top of the web frames. Where effective brackets are fitted, the length  $\ell$  may be modified as outlined in 3-2-6/7.1
- $h$  = vertical distance, in m (ft), from the middle of  $\ell$  to the load line; the value of  $h$  is not to be less than  $0.5\ell$
- $h_1$  = vertical distance, in m (ft), from the deck at the top of the web frame to the bulkhead or freeboard deck plus the height of all cargo tween-deck spaces and one-half the height of all passenger spaces above the bulkhead or freeboard deck or plus 2.44 m (8 ft), if that be greater. Where the cargo load differs from  $7.04 \text{ kN/m}^3$  ( $715 \text{ kgf/m}^3$ ,  $45 \text{ lbf/ft}^3$ ) multiplied by the tween-deck height in m (ft), the height of that tween-deck is to be proportionately adjusted in calculating  $h_1$

- $b$  = horizontal distance, in m (ft), from the outside of the frame to the first row of deck supports
- $K$  = 1.0, where the deck is longitudinally framed and a deck transverse is fitted in way of each web frame
- = number of transverse frame spaces between web frames where the deck is transversely framed

### 3.3 Hold Web Frames Forward

Hold web frames forward of the midship one-half length are to be obtained as described in 3-2-6/3.1, but the length  $\ell$  is to be increased in length due to shear. Where the shear is not less than normal, the other factors in 3-2-6/3.1 are to be the same as used for midship webs. Where there is no shear, the value of  $SM$  for the webs forward of the midship three-quarters length is to be increased 25%; where the shear is less than normal, the increase is to be proportionate.

**FIGURE 1**  
**Hold Web-frame Arrangements**



### 3.5 Proportions

Hold webs are to have a depth of not less than  $0.125\ell$  (1.5 in. per ft of span  $\ell$ ); the thickness is not to be less than 1 mm per 100 mm (0.01 in. per in.) of depth plus 3.5 mm (0.14 in.), but need not exceed 14 mm (0.56 in.). Where the webs are in close proximity to boilers, the thickness of the webs, face bars, flanges, etc. are to be increased 1.5 mm (0.06 in.) above the normal requirements.

### 3.7 Stiffeners (1994)

Where the shell is longitudinally framed, stiffeners attached to the longitudinal frames and extending to the full depth of the web frame are to be fitted at least at alternate longitudinal frames. Other stiffening arrangements may be considered based on the structural stability of the web plates.

### 3.9 Tripping Bracket (1994)

Tripping brackets are to be fitted at intervals of about 3 m (10 ft) and near the change of section. Where the breadth of the flanges on either side of the web exceeds 200 mm (8 in.), tripping brackets are to be arranged to support the flange.

### 3.11 Tween-deck Webs

Tween-deck webs are to be fitted below the bulkhead deck over the hold webs, as may be required to provide continuity of transverse strength above the main webs in the holds and machinery space.

## 5 Side Stringers

### 5.1 Hold Stringers

Each hold stringer, in association with web frames and transverse frames, is to have a section modulus  $SM$  not less than obtained from the following equation:

$$SM = 4.74chs\ell^2 \text{ cm}^3$$

$$SM = 0.0025chs\ell^2 \text{ in}^3$$

where

$$c = 1.50$$

$$h = \text{vertical distance, in m (ft), from the middle of } s \text{ to the load line, or to two-thirds of the distance from the keel to the bulkhead deck, or 1.8 m (6 ft), whichever is greatest}$$

$$s = \text{sum of the half lengths, in m (ft), (on each side of the stringer) of the frames supported}$$

$$\ell = \text{span, in m (ft), between web frames, or between web frame and bulkhead; where brackets are fitted, the length } \ell \text{ may be modified}$$

### 5.3 Proportions

Hold stringers are to have a depth of not less than  $0.125\ell$  (1.5 in. per ft of span  $\ell$ ) plus one-quarter of the depth of the slot for the frames, but need not exceed the depth of the web frames to which they are attached; in general, the depth is not to be less than 3 times the depth of the slots or the slots are to be fitted with filler plates; the thickness is not to be less than that determined by the equation in 3-2-6/9.1. Where the stringers are in close proximity to boilers, the thickness of the stringer plates, face bars, flanges, etc. are to be increased 1.5 mm (0.06 in.) above the normal requirements.

## 5.5 Stiffeners (1994)

Stiffeners attached to the frame and extending to the full depth of the stringer are to be fitted on alternate transverse frames. Other stiffening arrangement may be considered based on the structural stability of the web plates.

## 5.7 Tripping Brackets (1994)

The arrangement of tripping brackets is to be in accordance with 3-2-6/3.9.

# 7 Structural Arrangements and Details

## 7.1 Brackets of Girders, Webs, and Stringers

Where brackets are fitted having thickness not less than the girder or web plates, the value for  $\ell$ , as defined in this Section, Section 3-2-8, Section 3-2-9, and Section 3-2-10, may be modified in accordance with the following.

- i) Where the face area on the bracket is not less than one-half that on the girder or web and the face plate or flange on the girder or web is carried to the bulkhead or base, the length  $\ell$  may be measured to a point 150 mm (6 in.) on to the bracket.
- ii) Where the face area on the bracket is less than one-half that on the girder or web and the face plate or flange on the girder or web is carried to the bulkhead or base,  $\ell$  may be measured to a point where the area of the bracket and its flange, outside the line of the girder or web, is equal to the flange area on the girder.
- iii) Where the face plate or flange area of the girder or web is carried along the face of the bracket, which may be curved for the purpose,  $\ell$  may be measured to the point of the bracket.
- iv) Brackets are not to be considered effective beyond the point where the arm on the girder or web is 1.5 times the length of the arm on the bulkhead or base; in no case is the allowance in  $\ell$  at either end to exceed one-quarter of the overall length of the girder or web.

## 7.3 End Connections

End connections of all girders, webs and stringers should be balanced by effective supporting members on the opposite side of bulkheads, tank tops, etc., and their attachments are to be effectively welded.

End connections of side stringers are to be for the full depth of the web plate. Where the stringers are the same depth as the web frame, the standing flanges of the side stringers are to be attached.

# 9 Peak Stringers

## 9.1 Peak Stringer-plate Thickness

The peak stringer-plate thickness is not to be less than that obtained from the following equation.

$$\begin{aligned} t &= 0.014L + 7.2 \text{ mm} && \text{for } L \leq 200 \text{ m} \\ t &= 0.007L + 8.6 \text{ mm} && \text{for } 200 < L \leq 427 \text{ m} \\ t &= 0.00017L + 0.28 \text{ in.} && \text{for } L \leq 655 \text{ ft} \\ t &= 0.00008L + 0.34 \text{ in.} && \text{for } 655 < L \leq 1400 \text{ ft} \end{aligned}$$



where

$t$  = plate thickness, in mm (in.).

$L$  = length of vessel, as defined in 3-1-1/3.1, in m (ft)

### 9.3 Peak Stringer-plate Breadth

The peak stringer-plate breadth is not to be less than that obtained from the following equation.

$$b = 8.15L + 6 \text{ mm} \quad \text{for } L \leq 100 \text{ m}$$

$$b = 2.22L + 600 \text{ mm} \quad \text{for } 100 < L \leq 427 \text{ m}$$

$$b = 0.098L + 0.25 \text{ in.} \quad \text{for } L \leq 330 \text{ ft}$$

$$b = 0.027L + 23.5 \text{ in.} \quad \text{for } 330 < L \leq 1400 \text{ ft}$$

where

$b$  = breadth of peak stringer-plate, in mm (in.)

$L$  = length of vessel, as defined in 3-1-1/3.1, in m (ft)

Where beams or struts are not fitted on every frame, the edge of the stringer is to be adequately stiffened by a flange or face bar.

This Page Intentionally Left Blank

PART

# 3

CHAPTER **2 Hull Structures and Arrangements**

SECTION **7 Beams**

**1 General**

**1.1 Arrangement**

Transverse beams are to be fitted on every frame. Beams, transverses and girders are to have adequate structural stability.

**1.3 Design Head**

Where decks are designed to scantling heads less than those specified in this Section, a notation indicating the restricted deck loading will be entered in the *Record*.

**TABLE 1**  
**Values of  $h$  for Beams**

**Meters**

$L$	$a$	$b$	$c$	$d$	$e$	$f$	$g$
90	2.56	2.26	1.51	1.20	1.05	0.90	0.46
100	2.76	2.29	1.69	1.30	1.15	0.91	0.46
110	2.90	2.29	1.90	1.44	1.15	0.91	0.46
120	2.90	2.29	1.98	1.64	1.27	0.91	0.46
122 and above	2.90	2.29	1.98	1.68	1.30	0.91	0.46

**Feet**

$L$	$a$	$b$	$c$	$d$	$e$	$f$	$g$
300	8.50	7.50	5.00	4.00	3.50	3.00	1.50
325	9.00	7.50	5.50	4.25	3.75	3.00	1.50
350	9.50	7.50	6.00	4.50	3.75	3.00	1.50
375	9.50	7.50	6.50	5.00	4.00	3.00	1.50
400 and above	9.50	7.50	6.50	5.50	4.25	3.00	1.50

Values of  $h$  for an intermediate length of vessel are to be obtained by interpolation.

### 3 Beams

#### 3.1 Strength Requirement

Each beam, in association with the plating to which it is attached, is to have a section modulus  $SM$  as obtained from the following equation:

$$SM = 7.8chs\ell^2 \text{ cm}^3$$

$$SM = 0.0041chs\ell^2 \text{ in}^3$$

where

- $c$  = 0.540 for half beams, for beams with centerline support only, for beams between longitudinal bulkheads, and for beams over tunnels or tunnel recesses
- = 0.585 for beams between longitudinal deck girders. For longitudinal beams of platform decks and between hatches at all decks
- = 0.90 for beams at deep-tank tops supported at one or both ends at the shell or on longitudinal bulkheads
- = 1.00 for beams at deep-tank tops between longitudinal girders
- =  $1/(1.709 - 0.651k)$  for longitudinal beams of strength decks and of effective lower decks

$$k = SM_R Y / I_A$$

$SM_R$  = required hull girder section modulus amidships in 3-2-1/3.7.1 or 3-2-1/5.5, whichever is applicable, in  $\text{cm}^2\text{-m}$  ( $\text{in}^2\text{-ft}$ )

$Y$  = distance, in m (ft), from the neutral axis to the deck being considered, always to be taken positive

$I_A$  = hull girder moment of inertia of the vessel amidships, in  $\text{cm}^2\text{-m}^2$  ( $\text{in}^2\text{-ft}^2$ )

The values of  $I_A$  and  $Y$  are to be those obtained using the area of the longitudinal beams given by the above equation.

$s$  = spacing of beams, in m (ft)

$\ell$  = distance, in m (ft), from the inner edge of the beam knee to the nearest line of girder support or between girder supports, whichever is greater. Normally  $\ell$  is not to be less than  $0.2B$ . Under the top of deep tanks and in way of bulkhead recesses, the supports are to be arranged to limit the span to not over 4.57 m (15 ft)

$h$  = height, in m (ft), as follows

- = is normally to be the height measured at the side of the vessel, of the cargo space wherever stores or cargo may be carried. Where the cargo load differs from  $7.04 \text{ kN/m}^3$  ( $718 \text{ kgf/m}^3$ ,  $44.8 \text{ lbf/ft}^3$ ) multiplied by the tween-deck height, in m (ft), the height is to be proportionately adjusted.
- = for bulkhead recesses and tunnel flats is the height, in m (ft), to the bulkhead deck at the centerline; where that height is less than 6.10 m (20 ft), the value of  $h$  is to be taken as 0.8 times the actual height plus 1.22 m (4 ft).
- = for deep-tank tops is not to be less than two-thirds of the distance from the top of the tank to the top of the overflow; it is not to be less than given in column (e) of 3-2-7/Table 1, appropriate to the length of the vessel, the height to the load line or two-thirds of the height to the bulkhead or freeboard deck, whichever is greatest. The section modulus is not to be less than would be required for cargo beams.

Elsewhere, the value of  $h$  may be taken from the appropriate column of 3-2-7/Table 1, as follows.

<i>Weather deck and decks covered only by houses:</i>	<i>Column</i>
Freeboard decks having no decks below	a
Freeboard decks having decks below	b
Forecastle decks (first above freeboard deck) See Note 1	c
Bridge decks (first above freeboard deck)	c
Short bridges, not over $0.1L$ (first above freeboard deck)	d
Poop decks (first above freeboard deck)	d
Long superstructures (first above freeboard deck) forward of midship half-length	b
Long superstructures (first above freeboard deck) abaft midship half-length forward and forward of midship $\frac{3}{5}$ length aft	c
Long superstructures (first above freeboard deck) abaft midship $\frac{3}{5}$ length	d
Superstructure decks (second above freeboard deck) See Note 2	d
Superstructure decks (third and higher above freeboard deck) which contain only accommodation spaces	f
<i>Lower decks and decks within superstructures:</i>	
Decks below freeboard decks	c
Freeboard decks	c
Superstructure decks	d
Accommodation decks	f
<i>Decks to which side shell plating does not extend, tops of houses, etc.:</i>	
First tier above freeboard deck	d
Second tier above freeboard deck See Note 3	e
Third and higher tiers above freeboard deck See Note 3	f

*Notes*

- 1 See also 3-2-11/9.
- 2 Where superstructures above the first superstructure extend forward of the amidship  $0.5L$ , the value of  $h$  may be required to be increased.
- 3 Where decks to which the side shell does not extend and are generally used only as weather covering, the value of  $h$  may be reduced, but in no case is it to be less than in column (g).
- 4 Buckling strength of the plating and framing of all decks is to be considered where they are part of the hull girder.

### 3.3 Special Heavy Beams

Special heavy beams are to be arranged where the beams may be required to carry special heavy concentrated loads such as at the ends of deckhouses, in way of masts, winches, auxiliary machinery, etc.

### 3.5 Beams at the Head of Web Frames

Beams at the head of web frames are to be suitably increased in strength and stiffness.

### 3.7 End Connections

At the ends of unbracketed longitudinals, inside the line of openings or on platform decks, or at the ends of unbracketed beams, both the web and flange are to be welded to the supporting member. At beam knees or at other bracketed end connections, continuity of strength of the beam or longitudinal is to be maintained at the connection to the bracket and at the connection of the bracket to the supporting member. Welding is to be in accordance with 3-2-19/Table 1.

Deck longitudinals outside the line of openings are to be continuous or, at bulkheads, they are to have end connections that effectively develop their sectional area and resistance to bending.

Where beams or longitudinals are on, or terminate on, the boundaries of tanks or watertight compartments, structural continuity is to be maintained by a suitable back-up structure in way of the end connection, or the end connection is to be effectively extended by bracket or flat bar to an adjacent stiffener, etc.

## 4 Deck Fittings (1 October 2005)

### 4.1 General <No Text>

### 4.3 Design Loads <No Text>

### 4.5 Supporting Structures <No Text>

## 5 Container Loading

### 5.1 General

Where it is intended to carry containers, the exact locations of the container pads and the maximum total static load on the pads are to be indicated on the plans. Where the pads are not in line with the supporting structures, headers are to be provided to transmit the loads to these members.

### 5.3 Strength Requirements

Each member intended to support containers is to have a section modulus,  $SM$ , in  $\text{cm}^3$  ( $\text{in}^3$ ), not less than obtained from the following equation.

$$SM = M/f$$

where

$M$  = maximum bending moment due to maximum static container loading, in kN-cm, (tf-cm, Ltf-in)

$f$  = permissible maximum bending stress, as given in 3-2-7/Table 2

In determining the maximum bending moment, members may be considered fixed-ended, provided that the member is continuous over the adjacent spans or is effectively attached to a bulkhead stiffener or frame or has end connections in accordance with 3-2-7/3.7. Where this is not the case, the member is to be considered simply-supported. Where weather deck containers are supported by pedestals, the section modulus required by 3-2-7/3, with  $h$  equal to the distance between the deck and the underside of the container, but not greater than 50% of the value given in 3-2-7/Table 1, is to be added to the above required section modulus.

## 7 Higher-strength Materials

### 7.1 General

In general, applications of higher-strength materials for deck beams are to meet the requirements of this section, but may be modified as permitted by the following paragraph. Calculations are to be submitted to show adequate provision against buckling.

### 7.3 Beams of Higher-strength Materials

Each beam of higher-strength material, in association with the higher-strength plating to which it is attached, is to have a section modulus  $SM_{hts}$  not less than obtained from the following equation.

$$SM_{hts} = 7.8chs\ell^2Q \text{ cm}^3$$

$$SM_{hts} = 0.0041chs\ell^2Q \text{ in}^3$$

where

$c$ ,  $h$ ,  $s$  and  $\ell$  are as defined in 3-2-7/3 and  $Q$  is as defined in 3-2-1/5.5.

**TABLE 2**  
**Values of  $f$  (Ordinary-strength Steel)**

	$kN/cm^2$	$tf/cm^2$	$Ltf/in^2$
Effective longitudinal members	12.36	1.26	8
Transverse members and longitudinal members inside the line of openings	13.90	1.42	9

The net sectional area of the web of the member, in  $cm^2$  ( $in^2$ ), including effective brackets where applicable, is to be not less than obtained from the following equation:

$$A = F/q$$

$F$  = shearing force at the point under consideration, in kN, (tf, Ltf)

$q$  = allowable average shear stress in the web, not to exceed  $10.35 \text{ kN/cm}^2$  ( $1.055 \text{ tf/cm}^2$ ,  $6.7 \text{ Ltf/in}^2$ )

This Page Intentionally Left Blank



PART

# 3

CHAPTER **2 Hull Structures and Arrangements**

SECTION **8 Pillars, Deck Girders and Transverses**

**1 General (1997)**

**1.1 Arrangements – General**

Tween-deck pillars are to be arranged directly above those in the holds, or effective means are to be provided for transmitting their loads to the supports below. Pillars are to be fitted in line with a double-bottom girder or floor, or as close thereto as practicable. The seating under them is to be of ample strength and is to provide effective distribution of the load. Lightening holes are to be omitted in floors and girders directly under hold pillars.

Where longitudinal beams are used on more than one deck, transverses on the uppermost continuous deck and decks below, and on long superstructures and deck houses are to be fitted at the same vertical plane.

Special support is to be arranged at the ends and corners of deckhouses, in machinery spaces, at ends of partial superstructures and under heavy concentrated weights. For forecastle decks, see also 3-2-11/9.

**1.3 Container Loading**

Where it is intended to carry containers, the structure is to comply with 3-2-7/5.

**3 Pillars**

**3.1 Permissible Load (1994)**

The permissible load  $W_a$  of a pillar or strut is to be obtained from the following equation which will, in all cases, be equal to or greater than the calculated load  $W$  as determined in accordance with 3-2-4/7.7, 3-2-8/3.3, 3-2-8/3.5 or 3-2-8/3.7, as appropriate.

$$W_a = (k - n\ell/r)A \quad \text{kN (tf, Ltf)}$$

where

$k$	=	12.09 (1.232, 7.83)	ordinary strength steel
	=	16.11 (1.643, 10.43)	HT32 strength steel
	=	18.12 (1.848, 11.73)	HT36 strength steel
$\ell$	=	unsupported span of the pillar or strut, in m (ft), measured from the top of the inner bottom, deck or other structure on which the pillar is based to the underside of the beam or girder supported.	
$r$	=	least radius of gyration, in cm (in.).	
$A$	=	cross sectional area of strut, in cm <sup>2</sup> (in <sup>2</sup> )	
$n$	=	4.44 (0.452, 0.345)	ordinary strength steel
	=	7.47 (0.762, 0.581)	HT32 strength steel
	=	9.00 (0.918, 0.699)	HT36 strength steel

### 3.3 Calculated Load

The calculated load  $W$  for a specific pillar is to be obtained from the following equation.

$$W = nbhs \quad \text{kN (tf, Ltf)}$$

where

$n$	=	7.04 (0.715, 0.02)
$b$	=	mean breadth of the area supported, in m (ft)
$h$	=	height above the area supported as defined below, in m (ft)
$s$	=	mean length of the area supported, in m (ft)

For pillars spaced not more than two frame spaces, the height  $h$  is to be taken as the distance from the deck supported to a point 3.80 m (12.5 ft) above the freeboard deck.

For widely-spaced pillars, the height  $h$  is to be taken as the distance from the deck supported to a point 2.44 m (8 ft) above the freeboard deck, except in the case of such pillars immediately below the freeboard deck, in which case the value of  $h$  is not to be less than given in 3-2-7/Table 1, Column  $a$ . In measuring the distance from the deck supported to the specified height above the freeboard deck, the height for any tween decks devoted to passenger or crew accommodation may be taken as the height given in 3-2-7/3 for bridge-deck beams.

The height  $h$  for any pillar under the first superstructure above the freeboard deck is not to be less than 2.44 m (8 ft). The height  $h$  for any pillar is not to be less than the height given in 3-2-7/3 for the beams at the top of the pillar plus the sum of the heights given in the same paragraph for the beams of all complete decks and one-half the heights given for all partial superstructures above.

The height  $h$  for pillars under bulkhead recesses or the tops of tunnels is not to be less than the distance from the recess or tunnel top to the bulkhead deck at the centerline.

### 3.5 Special Pillars

Special pillars which are not directly in line with those above, or which are not on the lines of the girders, but which support the loads from above or the deck girders through a system of supplementary fore and aft or transverse girders, such as at hatch ends where the pillars are fitted only on the centerline, are to have the load  $W$ , for use with the equation proportionate to the actual loads transmitted to the pillars through the system of girders with modifications to the design value of  $h$  as described in 3-2-8/3.3.

### 3.7 Pillars Under the Tops of Deep Tanks (1994)

Pillars under the tops of deep tanks are not to be less than required by the foregoing. They are to be of solid sections and to have not less area than  $cW \text{ cm}^2 (\text{in}^2)$  where  $W$  and  $c$  are obtained as follows:

$$W = nbhs \quad \text{kN (tf, Ltf)}$$

where

$n$	=	10.5 (1.07, 0.03)	
$b$	=	breadth of the area of the top of the tank supported by the pillar, in m (ft)	
$s$	=	length of the area of the top of the tank supported by the pillar, in m (ft)	
$h$	=	height, as required by 3-2-7/3.1, for beams at the top of tanks, in m (ft)	
$c$	=	0.1035 (1.015, 0.16)	ordinary strength steel
	=	0.0776 (0.761, 0.12)	HT32 strength steel
	=	0.069 (0.677, 0.107)	HT36 strength steel

### 3.9 Bulkhead Stiffening

Bulkheads which support girders, or pillars and longitudinal bulkheads which are fitted in lieu of girders, are to be specially stiffened in such manner as to provide supports not less effective than required for stanchions or pillars.

### 3.11 Attachments

Widely-spaced tubular or solid pillars are to bear solidly at head and heel and are to be attached by welding, properly proportioned on the size of the pillar. The attachments of stanchions or pillars under bulkhead recesses, tunnel tops or deep-tank tops which may be subjected to tension loads are to be specially developed to provide sufficient welding to withstand the tension load.

## 5 Deck Girders and Transverses

### 5.1 General

Girders and transverses of the sizes required by 3-2-8/5.3 through 3-2-8/5.15 are to be fitted, as required to support the beams. In way of bulkhead recesses and the tops of tanks, they are to be arranged so that the unsupported spans of the beams do not exceed 4.57 m (15 ft). Additional girders are to be fitted, as required under masts, king posts, deck machinery or other heavy concentrated loads. In way of deck girders or special deep beams, the deck plating is to be of sufficient thickness and suitably stiffened to provide an effective part of the girder.

### 5.3 Deck Girders Clear of Tanks

Each deck girder clear of tanks, similar to that shown in 3-2-8/Figure 1, is to have a section modulus  $SM$  as obtained from the following equation.

$$SM = 4.74cbh\ell^2 \quad \text{cm}^3$$

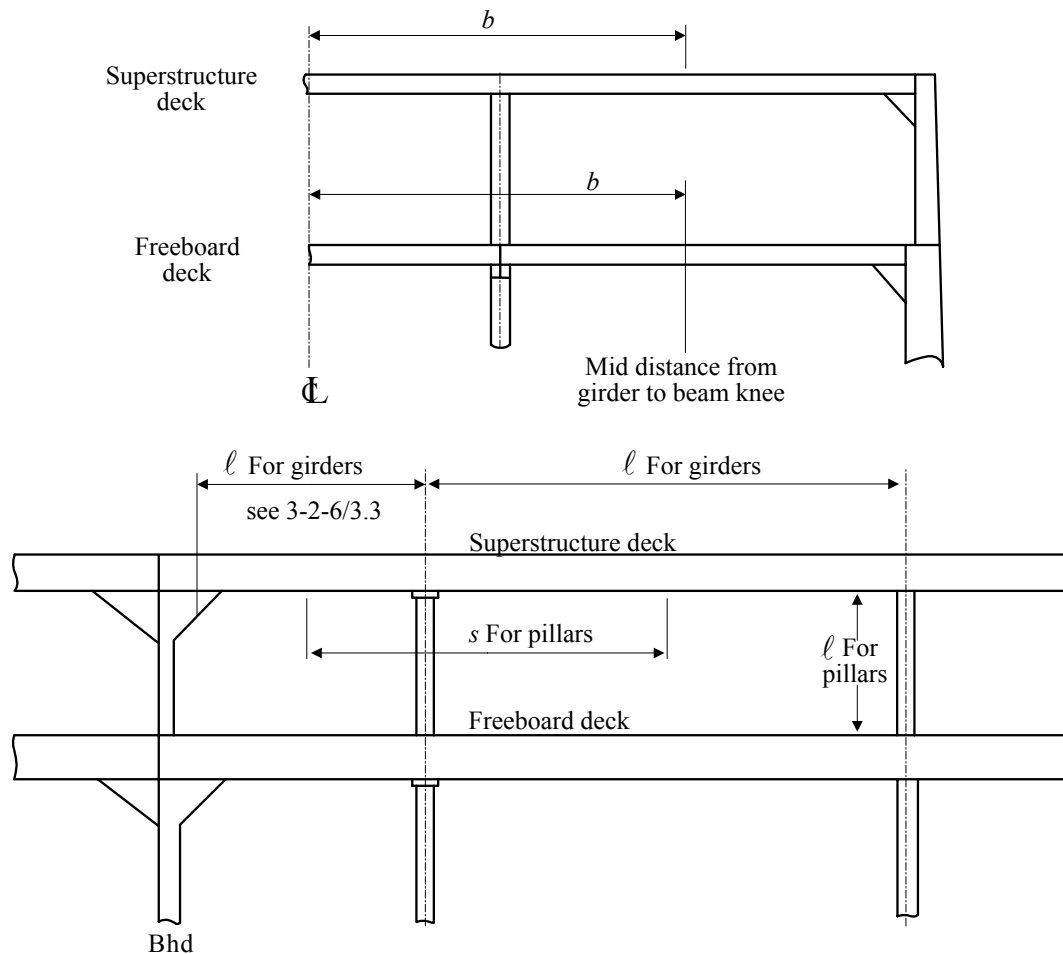
$$SM = 0.0025cbh\ell^2 \quad \text{in}^3$$

where

$c$	=	1.0	
$b$	=	mean breadth of the area of deck supported, in m (ft)	

- $h$  = height, as required by 3-2-7/3.1, for the beams supported, in m (ft)  
 $\ell$  = span between centers of supporting pillars, or between pillar and bulkhead, in m (ft). Where an effective bracket, in accordance with 3-2-6/7.1, is fitted at the bulkhead, the length  $\ell$  may be modified.

**FIGURE 1**  
**Deck Girders and Pillars**



### 5.5 Deck Transverses Clear of Tanks

Each deck transverse supporting longitudinal deck beams is to have a section modulus  $SM$  as obtained from the equations in 3-2-8/5.3 where

- $c$  = 1.0  
 $b$  = spacing of deck transverses, in m (ft)  
 $h$  = height, as required by 3-2-7/3.1, for the beams supported, in m (ft)  
 $\ell$  = span between supporting girders or bulkheads, or between girder and side frame, in m (ft). Where an effective bracket is fitted at the side frame or bulkhead, the length  $\ell$  may be modified. See 3-2-6/7.1.

## 5.7 Proportions

Girders and transverses are to have a depth of not less than  $0.0583\ell$  (0.7 in. per ft of span  $\ell$ ), the thickness is not to be less than 1 mm per 100 mm (0.01 in. per in.) of depth plus 4 mm (0.16 in.), but is not to be less than 8.5 mm (0.34 in.) where the face area is  $38 \text{ cm}^2$  ( $6 \text{ in}^2$ ) or less, 10 mm with  $63 \text{ cm}^2$  ( $0.40 \text{ in. with } 10 \text{ in}^2$ ), 12.5 mm with  $127 \text{ cm}^2$  ( $0.50 \text{ in. with } 20 \text{ in}^2$ ) and 15 mm with  $190 \text{ cm}^2$  ( $0.60 \text{ in. with } 30 \text{ in}^2$ ) or over. The thickness for intermediate area may be obtained by interpolation.

## 5.9 Tripping Brackets (1994)

Tripping brackets are to be fitted at intervals of about 3 m (10 ft.) and near the change of section. Where the breadth of the flanges on either side of the web exceeds 200 mm (8 in.), tripping brackets are to be arranged to support the flange. Additional supports are to be provided for the flanges where their breadth exceeds 400 mm (16 in.).

## 5.11 End Attachments

The ends of deck girders and transverses are to be effectively attached by welding.

## 5.13 Deck Girders and Transverses in Tanks

Deck girders and transverses in tanks are to be obtained in the same manner as given in 3-2-8/5.3, except that the value of  $c$  is to be equal to 1.50 and the minimum depth of the girder is to be  $0.0833\ell$  (1 in. per ft of span  $\ell$ ). The minimum thickness, sizes and arrangements of the stiffeners, tripping brackets and end connections are to be the same as given in 3-2-8/5.7, 3-2-8/5.9, and 3-2-8/5.11.

## 5.15 Hatch Side Girders (1997)

Scantlings for hatch side girders supporting athwartship shifting beams or supporting hatch covers are to be obtained in the same manner as deck girders (3-2-8/5.3 through 3-2-8/5.13). Such girders along lower deck hatches under trunks in which covers are omitted are to be increased in proportion to the extra load which may be required to be carried, due to loading up into the trunks. The structure on which the hatch covers are seated is to be effectively supported.

Where deep coamings are fitted above decks, such as at weather decks, the girder below deck may be modified so as to obtain a section modulus, when taken in conjunction with the coaming up to and including the horizontal coaming stiffener, of not less than 35% more than required by 3-2-8/5.3.

Where hatch side girders are not continuous under deck beyond the hatchways to the bulkheads, brackets extending for at least two frame spaces beyond the ends of the hatchways are to be fitted. Where hatch side girders are continuous beyond the hatchways, care is to be taken in proportioning their scantlings beyond the hatchway. Where the hatch side coaming is extended beyond the hatchway, it is not to be connected to the end bulkheads of superstructures or deckhouses, except where it is shown to be appropriate by detailed analysis.

Gusset plates are to be fitted at hatchway corners, arranged so as to effectively tie the flanges of the side coamings and extension pieces or continuous girders and the hatch-end beam flanges both beyond and in the hatchway.

# 7 Hatch-end Beams

## 7.1 Hatch-end Beam Supports

Each hatch-end beam, similar to that shown in 3-2-8/Figure 2, which is supported by a centerline pillar without a pillar at the corner of the hatchway, is to have a section modulus  $SM$  not less than obtained from the following equations:

7.1.1 Where Deck Hatch-side Girders are Fitted Fore and Aft Beyond the Hatchways

$$SM = K (AB + CD) h \ell \text{ cm}^3$$

$$SM = 5.267K (AB + CD) h \ell 10^{-4} \text{ in}^3$$

7.1.2 Where Girders are not Fitted on the Line of the Hatch Side Beyond the Hatchway

$$SM = KABh\ell \text{ cm}^3$$

$$SM = 5.267KABh\ell 10^{-4} \text{ in}^3$$

where

- $A$  = length of the hatchway, in m (ft)
- $B$  = distance from the centerline to the midpoint between the hatch side and the line of the toes of the beam knees, in m (ft)
- $C$  = distance from a point midway between the centerline and the line of the hatch side to the midpoint between the hatch side and the line of the toes of the beam knees, in m (ft). Where no girder is fitted on the centerline beyond the hatchway,  $C$  is equal to  $B$
- $D$  = distance from the hatch-end beam to the adjacent hold bulkhead, in m (ft)
- $h$  = height for the beams of the deck under consideration, as given in 3-2-7/3.1, in m (ft)
- $\ell$  = distance from the toe of the beam knee to the centerline plus 0.305 m (1 ft), in m (ft)
- $K$  =  $2.20 + 1.29(F/N)$  when  $F/N \leq 0.6$   
 =  $4.28 - 2.17(F/N)$  when  $F/N > 0.6$
- $N$  = one-half the breadth of the vessel in way of the hatch-end beam, in m (ft)
- $F$  = distance from the side of the vessel to the hatch side girder, in m (ft)

**7.3 Weather Deck Hatch-end Beams**

Weather deck hatch-end beams which have deep coamings above deck for the width of the hatch may have the flange area reduced from a point well within the line of the hatch side girder to approximately 50% of the required area at the centerline. In such cases, it is recommended that athwartship brackets be fitted above deck at the ends of the hatch-end coaming.

**7.5 Depth and Thickness**

The depth and thickness of hatch-end beams are to be similar to those required for deck girders by 3-2-8/5.7.

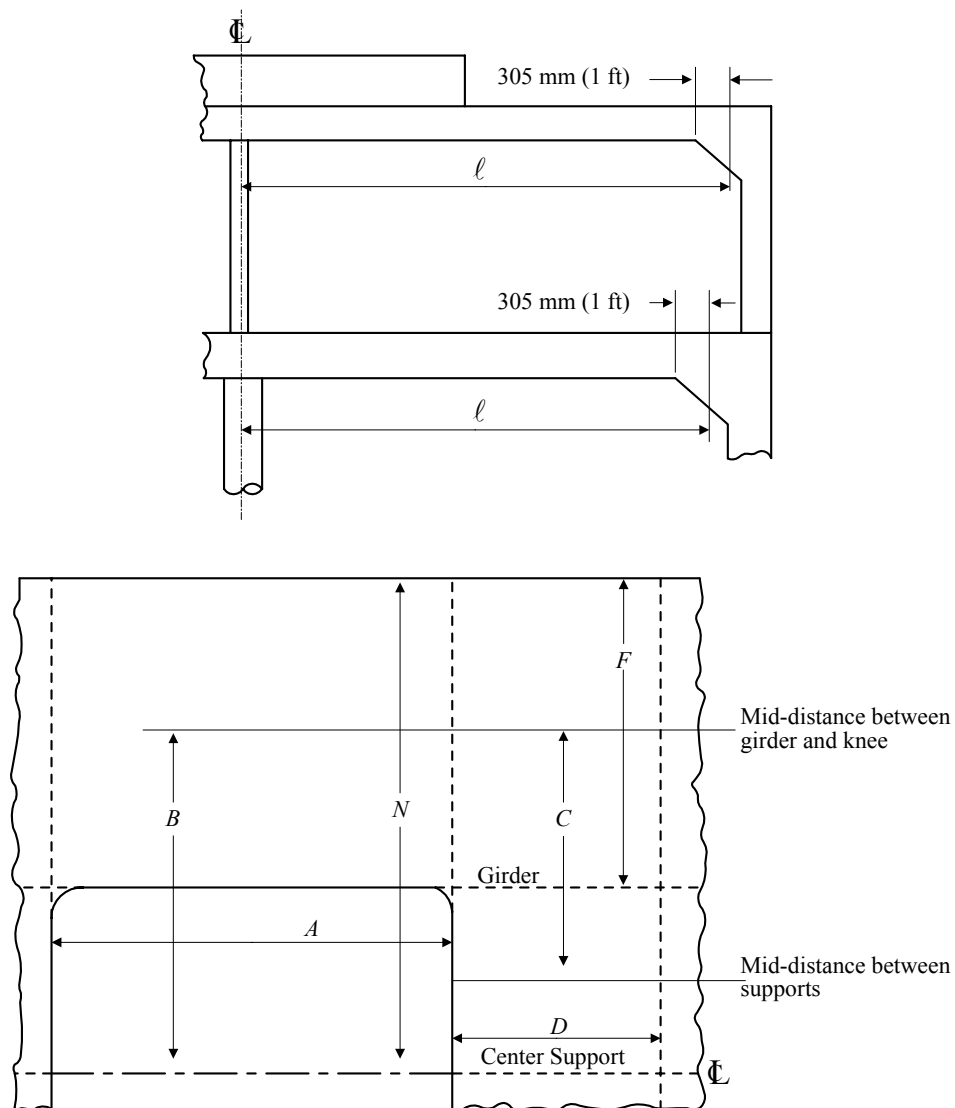
**7.7 Tripping Brackets (1994)**

The arrangement of tripping brackets is to be in accordance with 3-2-8/5.9.

**7.9 Brackets**

Brackets at the ends of hatch-end beams are to be generally as described in 3-2-6/7.1. Where brackets are not fitted, the length  $\ell$  is to be measured to the side of the vessel and the face plates or flanges on the beams are to be attached to the shell by heavy horizontal brackets extending to the adjacent frame.

**FIGURE 2**  
**Hatch-end Beams**



## 9 Higher-strength Materials

### 9.1 General

In general, applications of higher-strength materials for deck girders and deck transverses are to meet the requirements of this section, but may be modified as permitted by the following paragraphs. Calculations are to be submitted to show adequate provision to resist buckling.

### 9.3 Girders and Deck Transverses

Each girder and deck transverse of higher-strength material, in association with the higher-strength plating to which they are attached, are generally to comply with the requirements of the appropriate preceding paragraphs of this section and is to have a section modulus  $SM_{hts}$  not less than obtained from the following equation:

$$SM_{hts} = SM(Q)$$

where

- $SM$  = required section modulus in ordinary-strength material as determined elsewhere in this section
- $Q$  = as defined in 3-2-1/5.5



PART

**3**

CHAPTER **2 Hull Structures and Arrangements**

SECTION **9 Watertight Bulkheads and Doors**

**1 General**

**1.1 Application**

All vessels are to be provided with strength and watertight bulkheads in accordance with this section. In vessels of special type, alternative arrangements are to be specially approved. For passenger vessels, see the *ABS Guide for Building and Classing Passenger Vessels*. In all cases, the plans submitted are to clearly show the location and extent of the bulkheads. Watertight bulkheads constructed in accordance with the Rules will be recorded in the *Record* as **WT** (watertight), the symbols being prefixed in each case by the number of such bulkheads.

**1.3 Openings and Penetrations (2006)**

The number of openings in watertight subdivisions is to be kept to a minimum, compatible with the design and proper working of the vessel. Where penetrations of watertight bulkheads and internal decks (see 3-2-15/17.3) are necessary for access, piping, ventilation, electrical cables, etc., arrangements are to be made to maintain the watertight integrity. Relaxation in the watertightness of openings above the freeboard deck may be considered, provided it is demonstrated that any progressive flooding can be easily controlled and that the safety of the vessel is not impaired.

Ventilation penetrations through watertight subdivision bulkheads are to be avoided. Where penetrations are unavoidable, the ventilation ducting is to satisfy watertight bulkhead requirements or watertight closing appliances are to be installed at the bulkhead penetrations. For ventilation penetrations below the bulkhead deck or below damage equilibrium waterlines, the closing appliances are to be operable from the bridge. Where the penetration is located above the bulkhead deck and damage waterline, local manual controls may be provided at the closing appliances, on one or both sides of the bulkhead, so that the controls will be accessible in the prescribed flooded conditions.

**1.5 Sluice Valves and Cocks (1997)**

No valve or cock for sluicing purposes is to be fitted on a collision bulkhead. Where fitted on other watertight bulkheads, sluice valves or cocks are to comply with the requirements of 4-6-2/9.7.4.

**1.7 Strength Bulkheads**

All vessels are to have suitable arrangements to provide effective transverse strength and stiffness of the hull. This may be accomplished by fitting transverse bulkheads extending to the strength deck. In vessels of special type, equivalent transverse strength may be obtained by fitting substantial partial bulkheads, deep webs or combinations of these, so as to maintain effective transverse continuity of structure.

## 1.9 Testing

Requirements for testing are contained in Part 3, Chapter 7.

# 3 Arrangement of Watertight Bulkheads

## 3.1 Collision Bulkhead

### 3.1.1 General

A collision bulkhead is to be fitted on all vessels. It is to be intact, that is, without openings except as permitted in 4-6-2/9.7.3. It is to extend, preferably in one plane, to the freeboard deck. In the case of vessels having long superstructures at the fore end, it is to be extended weathertight to the superstructure deck. The extension need not be fitted directly over the bulkhead below, provided that the location of the extension meets the following requirements and the part of the deck which forms the step is made effectively weathertight.

On vessels with bow-doors, that part of their sloping loading ramps that form part of the extension of a collision bulkhead, and are more than 2.3 m (7.5 ft) above the freeboard deck, may extend forward of the limit below. See 3-2-9/Figure 1.

### 3.1.2 Location in Passenger Vessels

See subparagraph 2/11.5.2 of the ABS *Guide for Building and Classing Passenger Vessels*.

### 3.1.3 Location in All Other Vessels

In vessels other than passenger vessels, the collision bulkhead is to be located at any point not less than  $0.05L_r$  or 10 m (32.8 ft), whichever is less, abaft the reference point. At no point on any vessel, except as specially permitted, is it to be further than  $0.08L_r$  from the reference point.

### 3.1.4 Definitions

The reference point in determining the location of the collision bulkhead is the forward end of  $L_r$  except that in the case of vessels having any part of the underwater body, such as bulbous bow, extending forward of the forward end of  $L_r$ , the required distances are to be measured from a reference point located a distance forward of the forward end of  $L_r$ . This distance  $x$  is the least of the following:

- i) Half the distance between the forward end of  $L_r$  and the extreme forward end of the extension,  $p/2$
- ii)  $0.015L_r$  or
- iii) 3 m (9.84 ft). See 3-2-9/Figure 2.

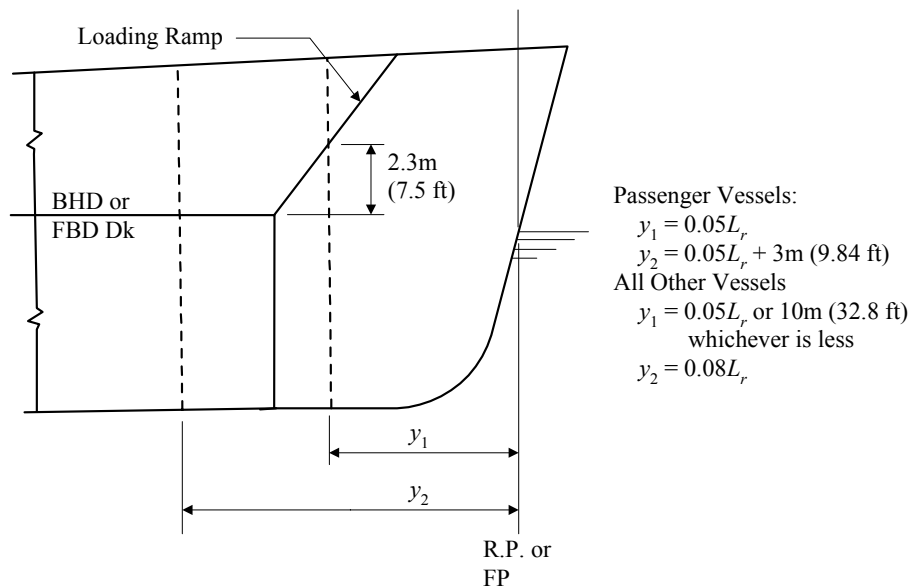
$L_r$  = (for passenger vessels) length between perpendiculars at the deepest subdivision load line. The forward end of  $L_r$  is to coincide with the fore side of stem on the waterline on which  $L_r$  is measured.

$L_r$  = (for other vessels)  $L_f$  as defined in 3-1-1/3.3.

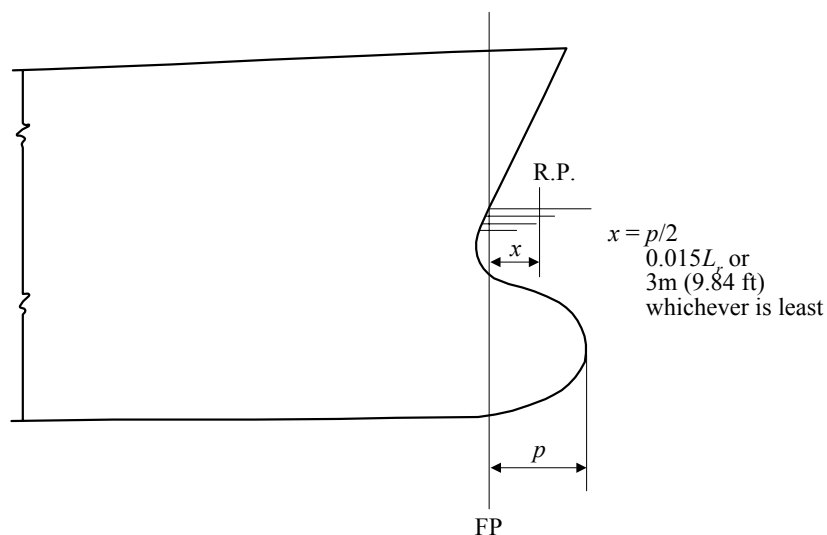
## 3.3 After-peak Bulkhead

An after-peak bulkhead is to be fitted in all screw vessels arranged to enclose the shaft tubes in a watertight compartment. The bulkhead is to extend to the strength deck, or efficient partial bulkheads are to extend thereto. The requirements of enclosing the shaft tube in a watertight compartment may be specially considered where such an arrangement is impracticable.

**FIGURE 1**  
**Collision Bulkhead in Vessels with Bow Door**



**FIGURE 2**  
**Reference Point for Vessels with Bulbous Bow**



### 3.5 Machinery Spaces

Machinery spaces are to be enclosed by watertight bulkheads which extend to the freeboard deck. In those cases where the length of the machinery space is unusually large in association with a small freeboard, the attention of designers is called to the desirability of extending the bulkheads to a deck above the freeboard deck, the fitting of an intermediate bulkhead, or the inclusion of a watertight deck over the machinery space which, in association with tight casings, might confine the amount of flooding in the event of damage in way of the machinery space. See 3-3-1/3.3.

### 3.7 Hold Bulkheads

#### 3.7.1 General (1997)

In addition to the foregoing required watertight bulkheads, the number and arrangement of hold bulkheads are to satisfy the subdivision and damage stability requirements in 3-3-1/3.3. Review procedures for this requirement are indicated in 3-3-1/5.

#### 3.7.2 Carriage of Water Ballast in Cargo Holds

Where a cargo hold is intended to be used for the carriage of water ballast or liquid cargoes, the hold is in general to be completely filled and the scantlings of the inner bottom, side structure, transverse bulkheads, deck and hatch covers are also to be in accordance with Section 3-2-10. The hatch cover and securing devices are to be suitable for the internal loading. See 3-2-15/9.

Special consideration may be given to the scantlings of cargo holds partially filled with water ballast or liquid cargoes. Full particulars are to be submitted.

### 3.9 Chain Lockers (*1 July 2003*)

Chain lockers and chain pipes are to be made watertight up to the weather deck. The arrangements are to be such that accidental flooding of the chain locker cannot result in damage to auxiliaries or equipment necessary for the proper operation of the vessel nor in successive flooding into other spaces.

Where means of access into chain lockers are provided, they are to be closed by a substantial cover secured by closely spaced bolts. Doors are not permitted.

For closure of chain pipes, see 3-2-15/21.11.

The arrangements on vessels that are not subject to the International Convention on Load Lines or its Protocol may be specially considered.

## 5 Construction of Watertight Bulkheads

### 5.1 Plating

Plating is to be of the thickness obtained from the following equation:

$$t = sk\sqrt{qh}/c + 1.5 \text{ mm} \quad \text{but not less than } 6 \text{ mm or } s/200 + 2.5 \text{ mm, whichever is greater}$$

$$t = sk\sqrt{qh}/c + 0.06 \text{ in.} \quad \text{but not less than } 0.24 \text{ in. or } s/200 + 0.10 \text{ in., whichever is greater}$$

where

$t$  = thickness, in mm (in).

$s$  = spacing of stiffeners, in mm (in.)

$k$  =  $(3.075\sqrt{\alpha} - 2.077)/(\alpha + 0.272)$  where  $1 \leq \alpha \leq 2$   
 = 1.0 where  $\alpha > 2$

$\alpha$  = aspect ratio of the panel (longer edge/shorter edge)

$q$  =  $235/Y$  N/mm<sup>2</sup> ( $24/Y$  kgf/mm<sup>2</sup>,  $34,000/Y$  psi)

$Y$  = specified minimum yield point or yield strength, in N/mm<sup>2</sup> (kgf/mm<sup>2</sup>, psi), as defined in 2-1-1/13, for the higher-strength material or 72% of the specified minimum tensile strength, whichever is the lesser

- $h$  = (1998) distance from the lower edge of the plate to the deepest equilibrium waterline in the one compartment damaged condition, in m (ft).
- For passenger vessels,  $h$  is to be taken as not less than the distance to the margin line.
  - For cargo vessels,  $h$  is to be not less than the distance to the bulkhead deck at center unless a deck lower than the uppermost continuous deck is designated as the freeboard deck, as allowed in 3-1-1/13.1. In such case,  $h$  is to be not less than the distance to the designated freeboard deck at center.
- $c$  = 254 (254, 460) for collision bulkhead  
 = 290 (290, 525) for other watertight bulkhead

The plating of afterpeak bulkheads below the lowest flat is not to be less than required for solid floors in the after peak space. See 3-2-5/9.

### 5.3 Stiffeners

Each stiffener, in association with the plating to which it is attached, is to have a section modulus  $SM$  not less than obtained from the following equation:

$$SM = 7.8chs\ell^2 \quad \text{cm}^3$$

$$SM = 0.0041chs\ell^2 \quad \text{in}^3$$

where

- $c$  = 0.30 for stiffeners having effective bracket attachments at both ends of their spans  
 = 0.43 for stiffeners having effective brackets at one end and supported by clip connections or by horizontal girders at the other end  
 = 0.56 for stiffeners having clip connections at both ends, or clip connections at one end and supported by horizontal girders at the other end, and for stiffeners in the uppermost tween decks having no end attachments  
 = 0.60 for other stiffeners having no end attachments and for stiffeners between horizontal girders
- $s$  = spacing of the stiffeners, in m (ft)
- $h$  = (1998) distance, in m (ft), from the middle of  $\ell$  to the deepest equilibrium waterline in the one compartment damaged condition.
- For passenger vessels,  $h$  is to be taken as not less than the distance to the margin line.
  - For cargo vessels,  $h$  is to be not less than the distance to the bulkhead deck at center unless a deck lower than the uppermost continuous deck is designated as the freeboard deck, as allowed in 3-1-1/13.1. In such case,  $h$  is to be not less than the distance to the designated freeboard deck at center.
  - For all vessels, where the distance indicated above is less than 6.10 m (20 ft),  $h$  is to be taken as 0.8 times the distance plus 1.22 m (4 ft).
- $\ell$  = distance between the heels of the end attachments; where horizontal girders are fitted,  $\ell$  is the distance from the heel of the end attachment to the first girder, or the distance between the horizontal girders, in m (ft)

The value of  $SM$  for stiffeners on collision bulkheads is to be at least 25% greater than required above for stiffeners on watertight bulkheads.

An effective bracket, for the application of the above values of  $c$ , is to have the scantlings not less effective than shown in 3-2-9/Table 1 and is to extend onto the stiffener for a distance at least one-eighth of the length  $\ell$  of the stiffener.

**TABLE 1**  
**Thickness and Flanges of Brackets and Knees**

Millimeters				Inches			
Depth of Longer Arm	Thickness		Width of Flange	Depth of Longer Arm	Thickness		Width of Flange
	Plain	Flanged			Plain	Flanged	
150	6.5			6.0	0.26		
175	7.0			7.5	0.28		
200	7.0	6.5	30	9.0	0.30	0.26	1 1/4
225	7.5	6.5	30	10.5	0.32	0.26	1 1/4
250	8.0	6.5	30	12.0	0.34	0.28	1 1/2
275	8.0	7.0	35	13.5	0.36	0.28	1 1/2
300	8.5	7.0	35	15.0	0.38	0.30	1 3/4
325	9.0	7.0	40	16.5	0.40	0.30	1 3/4
350	9.0	7.5	40	18.0	0.42	0.32	2
375	9.5	7.5	45	19.5	0.44	0.32	2
400	10.0	7.5	45	21.0	0.46	0.34	2 1/4
425	10.0	8.0	45	22.5	0.48	0.34	2 1/4
450	10.5	8.0	50	24.0	0.50	0.36	2 1/2
475	11.0	8.0	50	25.5	0.52	0.36	2 1/2
500	11.0	8.5	55	27.0	0.54	0.38	2 3/4
525	11.5	8.5	55	28.5	0.56	0.38	2 3/4
550	12.0	8.5	55	30.0	0.58	0.40	3
600	12.5	9.0	60	33.0		0.42	3 1/4
650	13.0	9.5	65	36.0		0.44	3 1/2
700	14.0	9.5	70	39.0		0.46	3 3/4
750	14.5	10.0	75	42.0		0.48	4
800		10.5	80	45.0		0.50	4 1/4
850		10.5	85				
900		11.0	90				
950		11.5	90				
1000		11.5	95				
1050		12.0	100				
1100		12.5	105				
1150		12.5	110				
1200		13.0	110				

Note: The thickness of brackets is to be suitably increased in cases where the depth at throat is less than two-thirds that of the knee.

## 5.5 Attachments

Lower brackets to inner bottoms are to extend over the floor adjacent to the bulkhead. Where stiffeners cross horizontal girders, they are to be effectively attached.

## 5.7 Girders and Webs

### 5.7.1 Strength Requirements

Each girder and web which supports bulkhead stiffeners is to have section modulus  $SM$  not less than obtained from the following equation:

$$SM = 4.74chs\ell^2 \text{ cm}^3$$

$$SM = 0.0025chs\ell^2 \text{ in}^3$$

where

$$c = 1.0$$

$$h = (1998) \text{ vertical distance, in m (ft), to the deepest equilibrium waterline in the one compartment damaged condition from the middle of } s \text{ in the case of girders and from the middle of } \ell \text{ in the case of webs.}$$

- For passenger vessels,  $h$  is to be taken as not less than the distance to the margin line.
- For cargo vessels,  $h$  is to be not less than the distance to the bulkhead deck at center unless a deck lower than the uppermost continuous deck is designated as the freeboard deck, as allowed in 3-1-1/13.1, in which case  $h$  is to be not less than the distance to the designated freeboard deck at center.
- For all vessels, where the distance indicated above is less than 6.10 m (20 ft), the value of  $h$  is to be 0.8 times the distance plus 1.22 m (4 ft).

$$s = \text{sum of half lengths (on each side of girder or web) of the stiffeners supported, in m (ft)}$$

$$\ell = \text{span measured between the heels of the end attachments, in m (ft).}$$

Where brackets are fitted, the length  $\ell$  may be modified as indicated in 3-2-6/7.1.

The section modulus  $SM$  of each girder and web on the collision bulkheads is to be at least 25% greater than required for similar supporting members on watertight bulkheads.

### 5.7.2 Proportions

Girders and webs are to have depths not less than  $0.0832\ell$  (1 in. per ft of span  $\ell$ ) plus one-quarter of the depth of the slots for the stiffeners; the thickness is not to be less than 1 mm per 100 mm (0.01 in. per in.) of depth plus 3 mm (0.12 in.) but need not exceed 11.5 mm (0.46 in.).

### 5.7.3 Tripping Brackets (1994)

Tripping brackets are to be fitted at intervals of about 3 m (10 ft), and near the change of section. Where the width of the face flange exceeds 200 mm (8 in.) on either side of the girder or web, tripping brackets are to be arranged to support the flange.

## 7 Construction of Corrugated Bulkheads

### 7.1 Plating

The plating of corrugated bulkheads is to be of the thickness required by 3-2-9/5.1 with the following modification. The spacing to be used is the greater of dimensions  $a$  or  $c$ , as indicated in 3-2-9/Figure 3. The angle  $\phi$  is to be 45 degrees or more.

### 7.3 Stiffeners (1996)

The section modulus  $SM$  for a corrugated bulkhead is to be not less than obtained from the following equation:

$$SM = 7.8chs\ell^2 \text{ cm}^3$$

$$SM = 0.0041chs\ell^2 \text{ in}^3$$

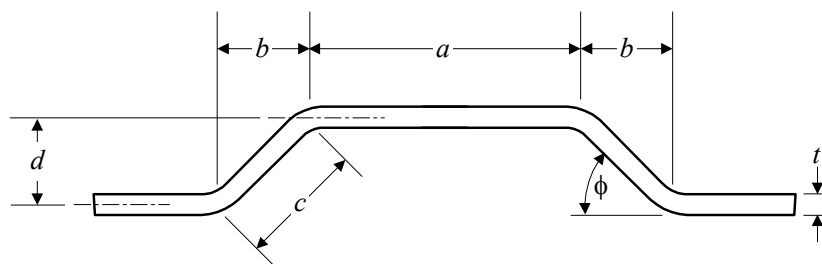
where

- $\ell$  = distance between supporting members, in m (ft). Where applicable, the distance  $\ell$  may be measured between the upper and lower stools, except that the credit for upper stools of rectangular cross section is not to exceed twice the width of the cross section. See 3-2-9/Figure 5
- $s$  = value determined using  $a + b$  (See 3-2-9/Figure 3)
- $c$  = 0.56
- $h$  = as defined in 3-2-9/5.3

The developed section modulus  $SM$  may be obtained from the following equation, where  $a$ ,  $t$  and  $d$  are as indicated in 3-2-9/Figure 3.

$$SM = td^2/6 + (adt/2)$$

**FIGURE 3**  
**Corrugated Bulkhead**

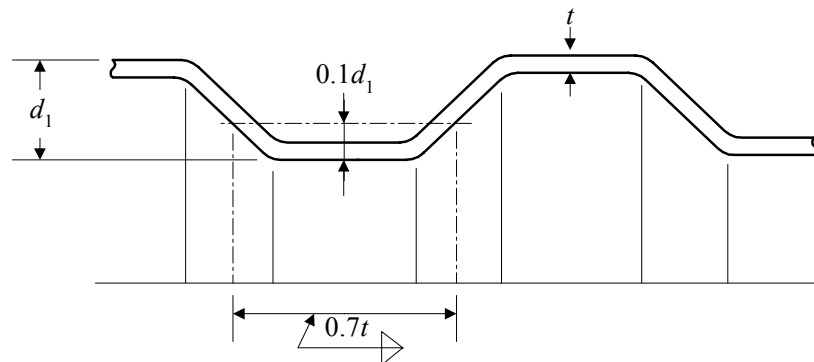


### 7.5 End Connections

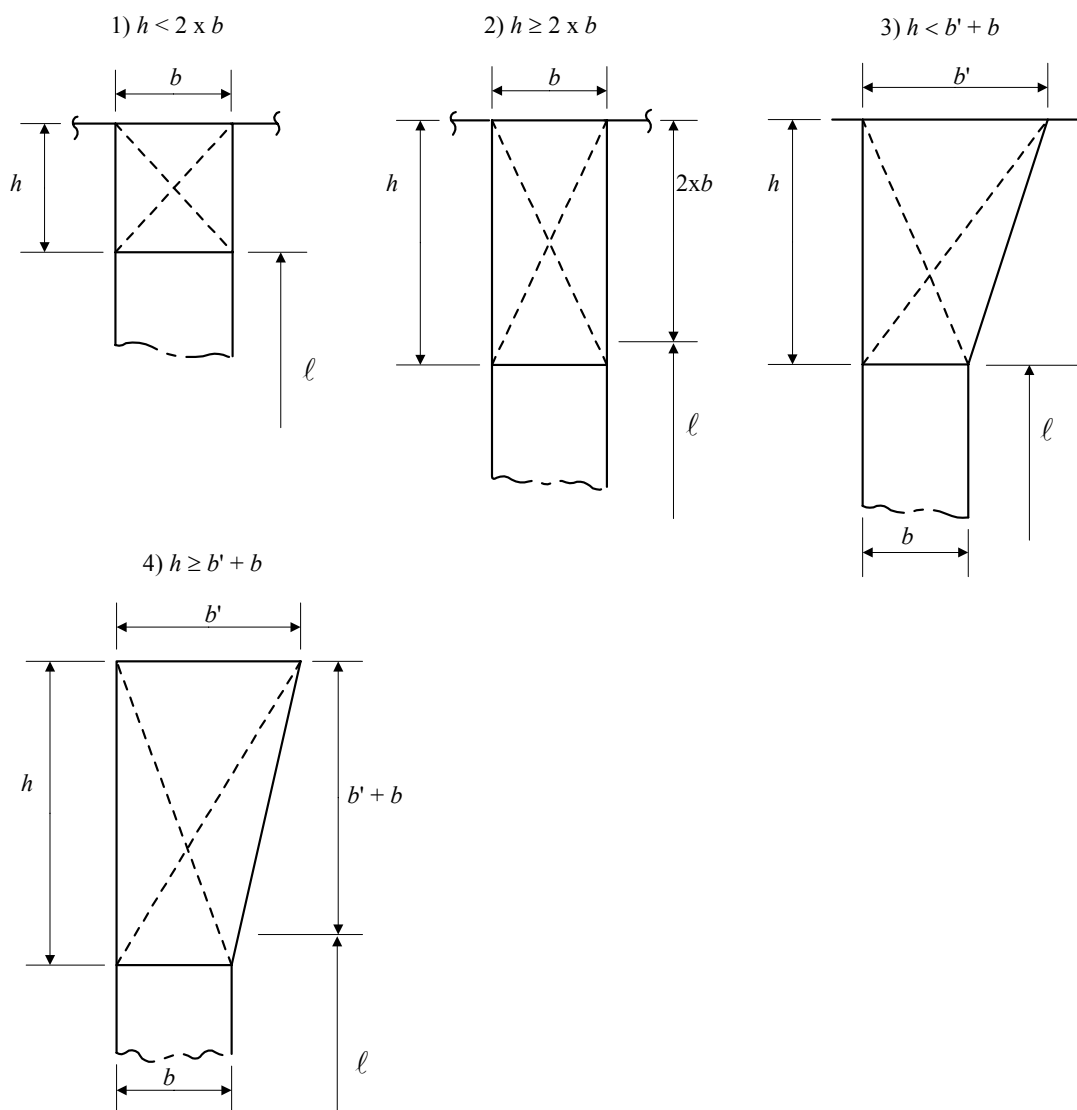
The structural arrangements and size of welding at the ends of corrugations are to be designed to develop the required strength of corrugated stiffeners. Joints within 10% of the depth of corrugation from the outer surface of corrugation,  $d_1$ , are to have double continuous welds with fillet size  $w$  not less than 0.7 times the thickness of bulkhead plating or penetration welds of equal strength. See 3-2-9/Figure 4 and 3-2-19/15.



**FIGURE 4**  
**Corrugated Bulkhead End Connections**



**FIGURE 5**  
**Corrugated Bulkhead Upper Stool Credit (1996)**



## 9 Watertight Doors

### 9.1 Doors Used While at Sea (2001)

Doors that are used while at sea are to be sliding watertight doors capable of being remotely closed from the bridge and are also to be operable locally from each side of the bulkhead. Indicators are to be provided at the control position showing whether the doors are open or closed, and an audible alarm is to be provided which is to sound whenever the door is closed remotely by power. See also 4-10-1/3.5. The power operated doors, control systems and indicators are to be functional in the event of main power failure. Particular attention is to be paid to minimize the effect of control system failure. Each power-operated sliding watertight door is to be provided with an individual hand-operated mechanism. It is to be possible to open and close the door by hand at the door itself from each side. See also Section 4-10-1.

### 9.3 Access Doors Normally Closed at Sea (2002)

Access doors and access hatch covers (see 3-2-15/17.3) normally closed at sea may be substantially constructed hinged type fitted with gaskets and dogs spaced and designed to ensure that the opening may be closed thoroughly watertight. These closing appliances are to be provided with means of indicating locally and on the bridge whether they are open or closed. A notice is to be affixed to each closing appliance to the effect that it is not to be left open.

Additionally, where a vessel is a Type A ship over 150 m (492 ft) in length or a Type B ship over 100 m (328 ft) in length, with a freeboard less than that based on Table B in Regulation 28 of the International Convention on Load Lines, 1966, the final waterline after flooding, taking into account sinkage, heel and trim, is to be below the lower edge of openings of those doors through which progressive downflooding may take place, unless the doors are remotely operated. Doors separating a main machinery space from the steering gear compartment may be hinged, quick acting type (e.g., all door dogs are in closed/opened position simultaneously by a manually-operated single handle or equivalent), provided that the sill of such doors is above the summer load waterline.

### 9.5 Doors or Ramps Dividing Large Cargo Spaces

Watertight doors or ramps (see 3-2-15/17.3) of satisfactory construction may be fitted to internally subdivide large cargo spaces, provided it is demonstrated to the Bureau that such doors or ramps are essential.

These doors or ramps may be hinged, rolling or sliding doors or ramps, but are not to be remotely controlled.

Such doors or ramps may be approved on condition that the shipboard personnel close them before the voyage commences and are kept closed during navigation. The time of opening such doors or ramps in port and of closing them before the vessel leaves port is to be recorded and entered in the logbook.

Doors or ramps accessible during the voyage are to be fitted with a device, which prevents unauthorized opening.

### 9.7 Other Openings Closed at Sea

Closing appliances which are to be kept permanently closed at sea, to ensure the watertight integrity of internal openings in watertight bulkheads and decks (see 3-2-15/17.3), that are not fitted with a device which prevents unauthorized opening are to be provided with a notice affixed to each such closing appliance to the effect that it is to be kept closed while the vessel is at sea. Manholes fitted with closely bolted covers need not be so marked.

## 9.9 Construction

Watertight doors are to be of ample strength for the water pressure to which they may be subjected. Doorframes are to be carefully fitted to the bulkheads; where liners are required, the material is to be not readily injured by heat or by deterioration. Sliding doors are to be carefully fitted to the frames.

Where stiffeners are cut in way of watertight doors, the openings are to be framed and bracketed to maintain the full strength of the bulkheads without taking the strength of the doorframes into consideration.

## 9.11 Testing at Sliding Door Manufacturer (1996)

Sliding doors are to be tested for operation at the manufacturer's plant. Hydrostatic testing of sliding doors is also to be carried out at the manufacturer's plant, with a head of water equivalent to the height to the bulkhead deck or freeboard deck at center.

This Page Intentionally Left Blank

PART

# 3

CHAPTER **2 Hull Structures and Arrangements**

SECTION **10 Deep Tanks**

**1 General**

**1.1 Application**

This Section applies to all deep tanks where the requirements in this Section exceed those of Section 3-2-9.

**1.3 Arrangement**

The arrangement of all deep tanks, together with their intended service and the height of the overflow pipes, is to be clearly indicated on the plans submitted for approval.

Tanks for fresh water or fuel oil or those that are not intended to be kept entirely filled in service, are to have divisions or deep swashes as may be required to minimize the dynamic stress on the structure. Oil or other liquid substances that are flammable are not to be carried in tanks forward of the collision bulkhead.

**1.5 Construction**

The boundary bulkheads of all deep tanks are to be constructed in accordance with the requirements of this section.

Longitudinal tight divisions, which are fitted for reasons of stability in tanks which are to be entirely filled or empty in service, may be of the scantlings required for watertight bulkheads by Section 3-2-9. In such cases, the tanks are to be provided with feed tanks or deep hatches, fitted with inspection plugs in order to ensure that the tanks on both sides of the bulkhead so designed are kept full when in service.

**1.7 Drainage and Air Escape**

Limber and air holes are to be cut in all parts of the structure, as required, to ensure the free flow to the suction pipes and the escape of air to the vents. Efficient arrangements are to be made for draining the spaces above deep tanks.

**1.9 Testing**

Requirements for testing are contained in Part 3, Chapter 7.

### 3 Construction of Deep Tank Bulkheads

Where the specific gravity of the liquid exceeds 1.05, the design head,  $h$ , in this section is to be increased by the ratio of the specific gravity of the liquid to be carried, to 1.05.

#### 3.1 Plating

Plating is to be of thickness obtained from the following equation:

$$t = (sk\sqrt{qh}/254) + 2.5 \text{ mm} \quad \text{but not less than } 6.5 \text{ mm or } s/150 + 2.5 \text{ mm, whichever is greater.}$$

$$t = (sk\sqrt{qh}/460) + 0.10 \text{ in.} \quad \text{but not less than } 0.25 \text{ in. or } s/150 + 0.10 \text{ in., whichever is greater.}$$

where

$t$  = thickness, in mm (in.)

$s$  = stiffener spacing, in mm (in.)

$k$  =  $(3.075\sqrt{\alpha} - 2.077)/(\alpha + 0.272)$  where  $1 \leq \alpha \leq 2$   
 = 1.0 where  $\alpha > 2$

$\alpha$  = aspect ratio of the panel (longer edge/shorter edge)

$q$  =  $235/Y$  N/mm<sup>2</sup> ( $24/Y$  kgf/mm<sup>2</sup>,  $34,000/Y$  psi)

$Y$  = specified minimum yield point or yield strength, in N/mm<sup>2</sup> (kgf/mm<sup>2</sup>, psi), as defined in 2-1-1/13, for the higher-strength material or 72% of the specified minimum tensile strength, whichever is the lesser

$h$  = the greatest of the following distances, in m (ft), from the lower edge of the plate to:

- a point located two-thirds of the distance from the top of the tank to the top of the overflow
- a point located above the top of the tank at a distance not less than given in column (e) of 3-2-7/Table 1, appropriate to the vessel's length
- the load line
- a point located at two-thirds of the distance to the bulkhead or freeboard deck

#### 3.3 Stiffeners

Each stiffener, in association with the plating to which it is attached, is to have section modulus  $SM$  not less than obtained from the following equation:

$$SM = 7.8chs\ell^2 \text{ cm}^3$$

$$SM = 0.0041chs\ell^2 \text{ in}^3$$

where

$c$  = 0.594 for stiffeners having effective bracket attachments at both ends

= 0.747 for stiffeners having effective bracket attachment at one end and supported by clip connections or by horizontal girders at the other end

- $c$  = 0.900 for stiffeners having clip attachments to decks or flats at both ends or having such attachments at one end with the other end supported by horizontal girders
- = 1.00 for stiffeners supported at both ends by horizontal girders
- $s$  = spacing of the stiffeners, in m (ft)
- $h$  = greatest of the following distances, in m (ft), from the middle of  $\ell$  to:
- a point located at two-thirds of the distance from the top of the tank to the top of the overflow
  - a point located above the top of the tank a distance not less than given in column (e) of 3-2-7/Table 1, appropriate to the vessel's length
  - the load line
  - a point located at two-thirds of the distance to the bulkhead or freeboard deck
- $\ell$  = distance, in m (ft), between the heels of the end attachments; where horizontal girders are fitted,  $\ell$  is the distance from the heel of the end attachment to the first girder or the distance between the horizontal girders.

An effective bracket for the application of these values of  $c$  is to have the scantlings not less effective than shown in 3-2-9/Table 1 and is to extend onto the stiffener for a distance at least one-eighth of the length  $\ell$  of the stiffener.

### 3.5 Tank-top Plating

Tops of tanks are to have plating 1 mm (0.04 in.) thicker than would be required for vertical plating at the same level; the thickness is not to be less than required for deck plating. Beams, girders and pillars are to be as required by Section 3-2-7 and Section 3-2-8.

### 3.7 Girders and Webs

#### 3.7.1 Strength Requirements

Each girder and web which support frames or beams in deep tanks is to have section modulus  $SM$  as required by Section 3-2-6 and Section 3-2-8 or as required by this paragraph, whichever is the greater; those which support bulkhead stiffeners are to be as required by this paragraph. The section modulus  $SM$  is to be not less than obtained from the following equation.

$$SM = 4.74chs\ell^2 \text{ cm}^3$$

$$SM = 0.0025chs\ell^2 \text{ in}^3$$

where

- $c$  = 1.50
- $h$  = vertical distance, in m (ft), from the middle of  $s$  in the case of girders and from the middle of  $\ell$  in the case of webs to the same heights to which  $h$  for the stiffeners is measured (see 3-2-10/3.3)
- $s$  = sum of half lengths (on each side of girder or web) of the frames or stiffeners supported, in m (ft)
- $\ell$  = span measured between the heels of the end of the attachments, in m (ft). Where effective brackets are fitted,  $\ell$  may be modified as indicated in 3-2-6/7.1.

Where efficient struts are fitted across tanks connecting girders on each side of the tanks and spaced not more than four times the depth of the girder, the value for the section modulus  $SM$  for each girder may be one-half that given above.

### 3.7.2 Proportions

Girders, except deck girders (see 3-2-8/5.13), and webs are to have depths not less than  $0.145\ell$  where no struts or ties are fitted, and  $0.0833\ell$  where struts are fitted, plus one-quarter of the depth of the slots for the frames or stiffeners. In general, the depth is not to be less than 3 times the depth of the slots; the thickness is not to be less than 1% of the depth plus 3 mm (0.12 in.) but need not exceed 11.5 mm (0.46 in.).

### 3.7.3 Tripping Brackets (1994)

Tripping brackets are to be fitted at intervals of about 3 m (10 ft) and near the change of section. Where the width of the face flange exceeds 200 mm (8 in.) on either side of the girder or web, tripping brackets are to be arranged to support the flange.

## 3.9 Corrugated Bulkheads

Where corrugated bulkheads are used as deep-tank boundaries, the scantlings may be developed from 3-2-9/7. The plating thickness  $t$  and value of  $SM$  are to be as required by 3-2-10/3.1 and 3-2-10/3.3 respectively with  $c = 0.90$ .

# 5 Higher-strength Materials

## 5.1 General

In general, applications of higher-strength materials for deep-tank plating are to meet the requirements of this section, but may be modified as permitted by the following paragraphs. Calculations are to be submitted to show adequate provision to resist buckling.

## 5.3 Plating

Deep-tank plating of higher-strength material is to be of not less thickness than obtained by 3-2-10/3.1.

## 5.5 Stiffeners

Each stiffener of higher-strength material, in association with the higher-strength plating to which it is attached, is to have section modulus  $SM_{hs}$  not less than obtained from the following equation:

$$SM_{hs} = 7.8chs\ell^2Q \text{ cm}^3$$

$$SM_{hs} = 0.0041chs\ell^2Q \text{ in}^3$$

where  $c$ ,  $h$ ,  $s$  and  $\ell$  are as defined in 3-2-10/3.3 and  $Q$  is as defined in 3-2-1/5.5.



PART

# 3

CHAPTER **2 Hull Structures and Arrangements**

SECTION **11 Superstructures, Deckhouses and Helicopter Decks**

**1 General Scantlings of Superstructures and Deckhouses**

**1.1 Side Plating**

Side plating of superstructures within the amidship  $0.4L$  of the vessel is to be obtained from 3-2-2/3. At the forward and after ends, the plating for  $0.1L$  from each end may be of the thickness obtained from 3-2-2/5.7 and 3-2-2/5.9 for forecastle and poop side plating respectively; beyond  $0.1L$  from each end, the thickness of the plating is to be gradually increased to that required within the amidship  $0.4L$  length.

**1.3 Decks (1997)**

**1.3.1 Superstructures**

Decks of superstructures having lengths greater than  $0.1L$  are to be considered as strength decks and are to comply with the requirements of 3-2-3/5. Where  $0.1L$  or less in length, the stringer plate may be the thickness of the side plating and the remainder of the deck plating is to meet the hull girder section modulus requirements of Section 3-2-1 if located within the  $0.4L$  amidships. The thickness of the plating at the forward and aft ends is to be obtained from 3-2-3/Table 1 for forecastle and poop deck plating.

**1.3.2 Deckhouses**

The top plating of long deckhouses is to be as required by 3-2-3/Table 1 line H. In addition, deckhouses located within  $0.4L$  amidships and having lengths over  $0.1L$  are to have plating meeting the hull girder requirements of Section 3-2-1.

**1.5 Frames**

Frames are to be of the sizes obtained from 3-2-5/5. Web frames or partial bulkheads are to be fitted over main bulkheads and elsewhere as may be required to give effective transverse rigidity to the structure.

**1.7 Breaks in Continuity**

Breaks in the continuity of superstructures are to be specially strengthened (see 3-2-2/11). The arrangements in this area are to be clearly shown on the plans submitted for approval.

### 3 Exposed Bulkheads

#### 3.1 General

The scantlings of the exposed bulkheads of superstructures and deckhouses are to be in accordance with the following paragraphs, except that the requirements for house side stiffeners need not exceed the requirements of Section 3-2-5 for the side frames directly below the deck on which the house is located. In general, the lowest tier is that on the freeboard deck.

Special consideration may be given to the bulkhead scantlings of deckhouses which do not protect openings in the freeboard deck, superstructure deck or in the top of a lowest tier deckhouse, or which do not protect machinery casings, provided they do not contain accommodation, or do not protect equipment essential to the operation of the vessel.

Superstructures or deckhouses located within the amidship  $0.4L$  and having lengths greater than  $0.1L$  are to have effective longitudinal scantlings to give a hull girder section modulus through the superstructure or deckhouse equal to that of the main hull girder. The superstructure scantlings are to be in accordance with 3-2-11/1 and the house top and side plating of long deckhouses is to be not less than obtained from equation 5 in 3-2-3/Table 2.

Partial bulkheads, deep webs, etc. are to be fitted at the ends and sides of large superstructures or deckhouses to provide resistance to racking.

#### 3.3 Plating

The plating is to be not less in thickness than obtained from the following equation:

$$t = 3s\sqrt{h} \text{ mm}$$

$$t = s\sqrt{h}/50 \text{ in.}$$

where  $s$  and  $h$  are as defined in 3-2-11/3.5; when determining  $h$ ,  $y$  is to be measured to the middle of the plate.

In no case is the thickness for the lowest tier bulkheads to be less than

$$5.0 + L_2/100 \text{ mm}$$

$$0.20 + L_2/8331 \text{ in.}$$

For other tier bulkheads, the thickness is not to be less than

$$4.0 + L_2/100 \text{ mm or } 5.0 \text{ mm, whichever is greater}$$

$$0.16 + L_2/8331 \text{ in. or } 0.20 \text{ in., whichever is greater}$$

where  $L_2$  is defined in 3-2-11/3.5.

#### 3.5 Stiffeners

Each stiffener, in association with the plating to which it is attached, is to have section modulus  $SM$  not less than obtained from the following equation:

$$SM = 3.5s\ell^2h \text{ cm}^3$$

$$SM = 0.00185s\ell^2h \text{ in}^3$$

where

$$s = \text{spacing of stiffeners, in m (ft)}$$

- $\ell$  = tween deck height, in m (ft)
- $h$  =  $a [(bf) - y]c$ , the design head, in m (ft).
- For unprotected front bulkheads on the lowest tier,  $h$  is not to be taken less than  $2.5 + L/100$  m ( $8.2 + L/100$  ft), in which  $L$  need not be taken as greater than 250 m (820 ft).
  - For all other bulkheads, the minimum value of  $h$  is to be not less than one-half the minimum required for unprotected front bulkheads on the lowest tier.
- $a$  = coefficient given in 3-2-11/Table 1
- $b$  =  $1.0 + \left[ \frac{(x/L) - 0.45}{C_b + 0.2} \right]^2$  where  $x/L \leq 0.45$
- =  $1.0 + 1.5 \left[ \frac{(x/L) - 0.45}{C_b + 0.2} \right]^2$  where  $x/L > 0.45$
- $C_b$  = block coefficient, as defined in 3-1-1/11.3, not to be taken as less than 0.60 nor greater than 0.80. For aft end bulkheads forward of amidships,  $C_b$  may be taken as 0.80.
- $x$  = distance, in m (ft), between the after perpendicular and the bulkhead being considered. Deckhouse side bulkheads are to be divided into equal parts not exceeding  $0.15L$  in length and  $x$  is to be measured from the after perpendicular to the center of each part considered.
- $L, L_2$  = length of vessel, in m (ft), but  $L_2$  need not be taken as greater than 300 m (984 ft)
- $f$  = value determined from 3-2-11/Table 2, in m (ft).
- $y$  = vertical distance, in m (ft), from the summer load waterline to the midpoint of the stiffener span
- $c$  =  $(0.3 + 0.7 b_1/B_1)$  but is not to be taken as less than 1.0 for exposed machinery casing bulkheads. In no case is  $b_1/B_1$  to be taken as less than 0.25.
- $b_1$  = breadth of deckhouse at the position being considered, in m (ft)
- $B_1$  = actual breadth of the vessel at the freeboard deck at the position being considered, in m (ft)

### 3.7 End Attachments

Both ends of the webs of lowest tier bulkhead stiffeners are to be effectively attached. The scantlings of stiffeners having other types of end connection are to be specially considered.

### 3.9 Raised Quarter Deck Bulkheads

Raised quarter deck bulkheads are to have plating of not less thickness than required for bridge-front bulkheads. The sizes of stiffeners are to be specially considered on the basis of the length of the vessel, the actual height of the raised quarter deck and the arrangement of the structure.

**TABLE 1**  
**Values of  $a$**

Bulkhead Location	SI Units and MKS Units	US Units
Unprotected front, lowest tier	$2.0 + L_2/120$	$2.0 + L_2/393.6$
Unprotected front, 2 <sup>nd</sup> tier	$1.0 + L_2/120$	$1.0 + L_2/393.6$
Unprotected front, 3rd tier	$0.5 + L_2/150$	$0.5 + L_2/492$
Protected front, all tiers	$0.5 + L_2/150$	$0.5 + L_2/492$
Sides, all tiers	$0.5 + L_2/150$	$0.5 + L_2/492$
Aft ends, aft of amidships, all tiers	$0.7 + (L_2/1000) - 0.8x/L$	$0.7 + (L_2/3280) - 0.8x/L$
Aft ends, forward of amidships, all tiers	$0.5 + (L_2/1000) - 0.4x/L$	$0.5 + (L_2/3280) - 0.4x/L$

**TABLE 2**  
**Values of  $f$**

Intermediate values of  $f$  may be obtained by interpolation

SI and MKS Units		US Units	
$L, m$	$f, m$	$L, ft$	$f, ft$
90	6.00	295	19.8
100	6.61	300	20.1
120	7.68	350	22.9
140	8.65	400	25.5
160	9.39	450	27.9
180	9.88	500	30.1
200	10.27	550	31.5
220	10.57	600	32.6
240	10.78	650	33.6
260	10.93	700	34.4
280	11.01	750	35.0
300 and greater	11.03	800	35.5
		850	35.8
		900	36.1
		950 and greater	36.2

Note The above table is based on the following equations:

$L$	$f$
<i>SI Units and MKS Units</i>	
$L \leq 150 m$	$(L/10)(e^{-L/300}) - [1 - (L/150)^2]$
$150 < L < 300 m$	$(L/10)(e^{-L/300})$
$L \geq 300 m$	11.03
<i>US Units</i>	
$L \leq 492 ft$	$(L/10)(e^{-L/984}) - [3.28 - (L/272)^2]$
$492 < L < 984 ft$	$(L/10)(e^{-L/984})$
$L \geq 984 ft$	36.2

## 5 Enclosed Superstructures

### 5.1 Openings in Bulkheads

All openings in the bulkheads of enclosed superstructures are to be provided with efficient means of closing so that in any sea condition water will not penetrate the vessel. Opening and closing appliances are to be framed and stiffened so that the whole structure is equivalent to the unpierced bulkhead when closed.

### 5.3 Doors for Access Openings

Doors for access openings into enclosed superstructures are to be of steel or other equivalent material, permanently and strongly attached to the bulkhead. The doors are to be provided with gaskets and clamping devices, or other equivalent arrangements, permanently attached to the bulkhead or to the doors themselves, and the doors are to be so arranged that they can be operated from both sides of the bulkhead.

### 5.5 Sills of Access Openings

Except as otherwise provided in these Rules, the height of the sills of access openings in bulkheads at the ends of enclosed superstructures is to be at least 380 mm (15 in.) above the deck.

For companionway sills, see 3-2-15/21.7.

### 5.7 Portlights

Portlights in the end bulkheads of enclosed superstructures are to be of substantial construction and provided with efficient inside deadlights. Also see 3-2-17/7.

### 5.9 Bridges and Poops

A bridge or poop is not regarded as enclosed unless an alternate means of access is provided for the crew from any point on the exposed portion of the uppermost continuous deck to reach the machinery space or other working spaces within these superstructures when the bulkhead openings are closed.

## 7 Open Superstructures

Superstructures with openings which do not fully comply with 3-2-11/5 are to be considered as open superstructures.

## 9 Forecastle Structures (2002)

Forecastle structures on vessels with minimum freeboard are to be supported by girders in association with deep beams and web frames, preferably arranged in complete transverse belts and supported by lines of pillars extending continuously down into the structure below. Beams and girders are to be arranged, where practicable, to limit the spans to about 3 m (10 ft). Pillars are to be provided as required by 3-2-8/3.1, except that generally the diameter of pillars is not to be less than 200 mm (8 in.) for vessels possibly subjected to green water on the deck. Main structural intersections are to be carefully developed with special attention given to pillar head and heel connections, and to the avoidance of stress concentrations.

## 11 Helicopter Decks

### 11.1 General

Helicopter decks, where provided, are to meet the following structural and safety requirements. The attention of owners, builders and designers is directed to various international and governmental regulations and guides regarding the operational and other design requirements for helicopters landing on ships. See also Section 1-1-5, 4-6-4/3.9.2 and 4-6-7/9.

Plans showing the arrangement, scantlings and details of the helicopter deck are to be submitted. The arrangement plan is to show the overall size of the helicopter deck and the designated landing area. If the arrangement provides for the securing of a helicopter or helicopters to the deck, the predetermined position(s) selected to accommodate the secured helicopter, in addition to the locations of deck fittings for securing the helicopter, are to be shown. The type of helicopter to be considered is to be specified and calculations for appropriate loading conditions are to be submitted.

### 11.3 Structure

Scantlings of helicopter decks and supporting structure are to be determined on the basis of the following loading conditions, whichever is greater, in association with the allowable factors of safety shown in 3-2-11/Table 3. Plastic design considerations may be applied for deck plating and stiffeners.

#### 11.3.1 Overall Distributed Loading

A minimum distributed loading of  $2.01 \text{ kN/m}^2$  ( $205 \text{ kgf/m}^2$ ,  $42 \text{ lbf/ft}^2$ ) is to be taken over the entire helicopter deck.

#### 11.3.2 Helicopter Landing Impact Loading

A load of not less than 75% of the helicopter maximum take-off weight is to be taken on each of two square areas,  $0.3 \text{ m} \times 0.3 \text{ m}$  ( $1 \text{ ft} \times 1 \text{ ft}$ ). Alternatively, the manufacturer's recommended wheel impact loading will be considered. The deck is to be considered for helicopter landings at any location within the designated landing area. The structural weight of the helicopter deck is to be added to the helicopter impact loading when considering girders, stanchions, truss supports, etc. Where the upper deck of a superstructure or deckhouse is used as a helicopter deck and the spaces below are normally manned (quarters, bridge, control room, etc.), the impact loading is to be multiplied by a factor of 1.15.

#### 11.3.3 Stowed Helicopter Loading

If provisions are made to accommodate helicopters secured to the deck in a predetermined position, the structure is to be considered for a local loading equal to the manufacturer's recommended wheel loading at maximum take-off weight, multiplied by a dynamic amplification factor based on the predicted motions of the vessel for this condition, as may be applicable for the vessel under consideration.

In addition to the helicopter load, a uniformly distributed loading of  $490 \text{ N/m}^2$  ( $50 \text{ kgf/m}^2$ ,  $10.5 \text{ lbf/ft}^2$ ), representing wet snow or ice, is to be considered, if applicable. For the girders, stanchions, truss supports, etc., the structural weight of the helicopter deck is also to be considered.

#### 11.3.4 Loading due to Motions of Vessel

The structure supporting helicopter decks is to withstand the loads resulting from the motions of the vessel.

### 11.3.5 Special Landing Gear

Helicopters fitted with landing gear other than wheels will be specially considered.

### 11.3.6 Environmental Loading

Calculations are to consider anticipated wind and wave impact loading on helicopter decks and their supporting structures.

**TABLE 3**  
**Allowable Factors of Safety Based on  $Y$  for Helicopter Decks**

$Y$  = specified minimum yield point or yield strength of the material as defined in 2-1-1/13

	<i>Plating</i>	<i>Beams</i>	<i>Girders, Stanchions, Truss Supports, etc. (See Note 3)</i>
Overall Distributed Loading	1.67	1.67	1.67
Helicopter Landing Impact Loading	<i>(See Note 1)</i> <i>(See Note 2)</i>	1.00	1.10
Stowed Helicopter Loading	1.00	1.10	1.25

Notes:

- 1 The minimum plate thickness  $t$  is generally not to be less than obtained from the following: (1999)

<i>Beam spacing</i>	<i>t</i>	<i>Beam spacing</i>	<i>t</i>
460 mm	4.0 mm	18 in.	0.16 in.
610 mm	5.0 mm	24 in.	0.20 in.
760 mm	6.0 mm	30 in.	0.24 in.

- 2 An allowable stress that exceeds  $Y$  may be considered provided the rationale of the submitted analysis is sufficiently conservative.
- 3 For members subjected to axial compression, the factor of safety is to be based on the yield stress or critical buckling stress, whichever is less.
- 4 The minimum plate thickness for materials other than steel will be specially considered. (1999)

## 11.5 Safety Net

The unprotected perimeter of the helicopter landing deck is to be provided with safety netting or equivalent.

## 11.7 Material (1999)

In general, the construction of helicopter decks is to be of steel or other material with equivalent ability to retain structural capacity in a fire. If the helicopter deck forms the deckhead of a deckhouse or superstructure, it is to be insulated to A-60 class standard.

Aluminum alloys may be used for helicopter decks above deckhouses, provided the following conditions are complied with:

- i) There are to be no openings in the exterior bulkheads directly below the helicopter deck
- ii) All windows in the lower exterior bulkheads are to be fitted with steel shutters.

### 11.9 Means of Escape and Access (1999)

The helicopter deck is to be provided with both a main and an emergency means of escape and access for fire fighting and rescue personnel. These means are to be located as far apart from each other as is practicable and preferably on opposite sides of the helicopter deck.



PART

**3**

CHAPTER **2 Hull Structures and Arrangements**

SECTION **12 Machinery Space and Tunnel**

**1 General**

**1.1 Arrangement**

In view of the effect upon the structure of the necessary openings in the machinery space, the difficulty of securing adequate support for the decks, of maintaining the stiffness of sides and bottom and of distributing the weight of the machinery, special attention is directed to the need for arranging, in the early stages of design, for the provision of plated through beams and such casing and pillar supports as are required to secure structural efficiency. Careful attention to these features in design and construction is to be regarded as of the utmost importance. All parts of the machinery, shafting, etc., are to be efficiently supported and the adjacent structure is to be adequately stiffened. In twin-screw vessels, and in other vessels of high power, it will be necessary to make additions to the strength of the structure and the area of attachments, which are proportional to the weight, power and proportions of the machinery, more especially where the engines are relatively high in proportion to the width of the bed plate. The height and approximate weight of engines are to be stated upon the bolting plan, which is to be approved before the bottom construction is commenced. A determination is to be made to assure that the foundations for main propulsion units, reduction gears, shaft and thrust bearings, and the structure supporting those foundations are adequate to maintain required alignment and rigidity under all anticipated conditions of loading. Consideration is to be given to the submittal of plans of the foundations for main propulsion units, reduction gears, and thrust bearings and of the structure supporting those foundations to the machinery manufacturer for review. (See 4-3-2/7).

**1.3 Testing of Tunnels**

Requirements for testing are contained in Part 3, Chapter 7.

**3 Engine Foundations**

**3.1 Engine Foundations in Double-bottom Vessels**

In vessels with double bottoms, the engines are to be seated directly upon thick inner-bottom plating or upon thick seat plates on top of heavy foundations arranged to distribute the weight effectively. Additional intercostal girders are to be fitted within the double bottom to ensure the satisfactory distribution of the weight and the rigidity of the structure.

### 3.3 Boiler Foundations

Boilers are to be supported by deep saddle-type floors or by transverse or fore-and-aft girders arranged to distribute the weight effectively. Where they are supported by transverse saddles or girders, the floors in way of boilers are to be suitably increased in thickness and specially stiffened. Boilers are to be placed to ensure accessibility and proper ventilation. They are to be at least 460 mm (18 in.) clear of tank tops, bunker walls, etc. The thickness of adjacent material is to be increased as may be required where the clear space is unavoidably less. The available clearance is to be indicated on the plans submitted for approval.

### 3.5 Thrust Foundations

Thrust blocks are to be bolted to efficient foundations extending well beyond the thrust blocks and arranged to distribute the loads effectively into the adjacent structure. Extra intercostal girders, effectively attached, are to be fitted in way of the foundations, as may be required.

### 3.7 Shaft Stools and Auxiliary Foundations

Shaft stools and auxiliary foundations are to be of ample strength and stiffness in proportion to the weight supported.

## 5 Tunnels and Tunnel Recesses

### 5.1 Plating

The plating of flat sides of shaft or other watertight tunnels is to be of the thickness as obtained from 3-2-9/5.1 for watertight bulkheads; but the lowest strake of the plating is to be increased 1 mm (0.04 in.). Flat plating on the tops of tunnels or tunnel recesses is to be of the thickness required for watertight bulkhead plating at the same level, where unsheathed in way of hatches, the thickness is to be increased 2 mm (0.08 in.). Where the top of the tunnel or recess forms a part of a deck, the thickness is not to be less than required for the plating of watertight bulkheads at the same level plus 1 mm (0.04 in.), nor than would be required for the deck plating. Curved plating may be of the thickness required for watertight bulkhead plating at the same level in association with a stiffener spacing 150 mm (6 in.) less than that actually adopted. Crown plating in way of hatches is to be increased at least 2.5 mm (0.10 in.) or is to be protected by wood sheathing not less than 50 mm (2 in.) thick.

### 5.3 Stiffeners

Stiffeners are not to be spaced more than 915 mm (36 in.) apart, and each stiffener, in association with the plating to which it is attached, is to have a section modulus  $SM$  not less than obtained from the following equation:

$$SM = 4.42 \, h s \ell^2 \quad \text{cm}^3$$

$$SM = 0.0023 \, h s \ell^2 \quad \text{in}^3$$

where

$h$  = distance, in m (ft), from the middle of  $\ell$  to the bulkhead deck

$s$  = spacing of stiffeners, in m (ft)

$\ell$  = distance, in m (ft), between the top and bottom supporting members without brackets

The ends of stiffeners are to be welded to the top and bottom supporting members. Where masts, stanchions, etc., are stepped upon tunnels, local strengthening is to be provided proportional to the weight carried.

### 5.5 Beams, Pillars and Girders

Beams, pillars and girders under the tops of tunnels, or tunnel recesses are to be as required for similar members on bulkhead recesses.

### 5.7 Tunnels Through Deep Tanks

Where tunnels pass through deep tanks, the thickness of the plating and the size of the stiffeners in way of the tanks is not to be less than required for deep-tank bulkheads. Tunnels of circular form are to have plating of not less thickness  $t$  than obtained from the following equation:

$$t = 0.1345 dh + 9 \text{ mm}$$

$$t = 0.000492 dh + 0.36 \text{ in.}$$

where

$d$  = diameter of the tunnel, in m (ft)

$h$  = distance, in m (ft), from the bottom of the tunnel to the highest point of the following:

- the load line
- the highest level to which the tank contents may rise in service conditions
- a point located at a distance two-thirds  $D$ , as defined in 3-1-1/7.1, above the baseline
- a point located two-thirds of the test head above the top of the tank

This Page Intentionally Left Blank

PART

# 3

CHAPTER **2 Hull Structures and Arrangements**

SECTION **13 Stems, Stern Frames and Rudder Horns**

## 1 Stems

### 1.1 Plate Stems

Plate stems, where used, are not to be less in thickness at the design load waterline than required by the following equations.

$$\begin{aligned} t &= 1.46 + L/12 \text{ mm} & L \leq 245 \text{ m} \\ t &= 22 \text{ mm} & 245 < L \leq 427 \text{ m} \\ t &= 0.06 + L/1000 \text{ in.} & L \leq 800 \text{ ft} \\ t &= 0.86 \text{ in.} & 800 < L \leq 1400 \text{ ft} \end{aligned}$$

Above and below the design load waterline, the thickness may taper to the thickness of the shell at ends at the freeboard deck and to the thickness of the flat-plate keel at the forefoot, respectively.

### 1.3 Cast-steel Stems

Cast-steel stems of special shape are to be proportioned to provide a strength at least equivalent to that of a plate stem, and all joints and connections are to be at least that effective.

## 3 Stern Frames

### 3.1 General

Stern frames may be fabricated from steel plates or made of cast steel. For applicable material specifications and steel grades, see 3-1-2/1.1.1 and 3-1-2/Table 2. The scantlings are to comply with 3-2-13/3.5 and 3-2-13/3.7. Stern frames of other material or construction will be specially considered.

### 3.3 Rudder Gudgeons (1993)

Rudder gudgeons are to be an integral part of the stern frame. The bearing length of the pintle is to be between 1.0 and 1.2 times the pintle diameter. The thickness of the pintle housing is not to be less than 25% of the pintle diameter.

### 3.5 Scantlings Below the Propeller Boss

Except as modified in 3-2-13/3.7, the scantlings of stern frames of single screw vessels are to be in accordance with the following, as applicable:

#### 3.5.1 Fabricated Stern Frame

The thickness  $t$ , width  $w$  and  $tw^2\sqrt{1+(2\ell/w)^2}$  for fabricated stern frames are to be not less than those given by the following equations:

$$t = 0.225\sqrt{L} \text{ cm} \quad t = \sqrt{L} / 20.5 \text{ in.}$$

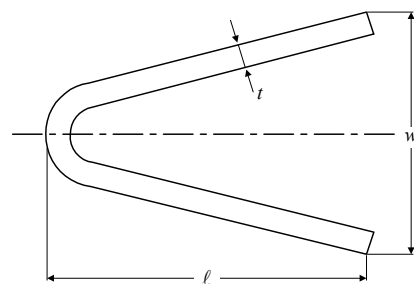
$$w = 45 \text{ cm} \quad w = 17.7 \text{ in.}$$

$$tw^2\sqrt{1+(2\ell/w)^2} = C_f L^{1.5}$$

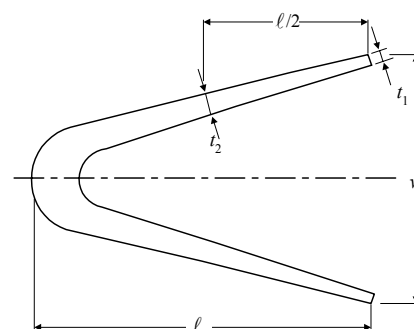
where

- $t$  = thickness of side plating (See 3-2-13/Figure 1)
- $w$  = width of stern frame (See 3-2-13/Figure 1)
- $\ell$  = length of stern frame, in cm (in.) (See 3-2-13/Figure 1)
- $L$  = length of vessel, as defined in 3-1-1/3.1
- $C_f$  = 9.6 (9.6, 0.1)

**FIGURE 1  
Stern Frame**



a Fabricated



b Cast

### 3.5.2 Cast Stern Frame

The thicknesses  $t_1$ ,  $t_2$  and  $\frac{(t_1+t_2)}{2} w^2 \sqrt{1+(2\ell/w)^2}$  for cast stern frames are to be not less than given by the following equations:

$$t_1 = 0.3\sqrt{L} \text{ cm} \quad \text{but not less than 2.5 cm}$$

$$t_1 = \sqrt{L}/15.3 \text{ in.} \quad \text{but not less than 1.0 in.}$$

$$t_2 = 1.25t_1$$

$$\frac{(t_1+t_2)}{2} w^2 \sqrt{1+(2\ell/w)^2} = C_c L^{1.5}$$

where

$w, \ell, L$  = as defined in 3-2-13/3.5.1.

$t_1$  = thickness of casting at end. (See 3-2-13/Figure 1)

$t_2$  = thickness of casting at mid-length (See 3-2-13/Figure 1)

$C_c$  = 8.4 (8.4, 0.086)

The thickness in way of butt welding to shell plating may be tapered below  $t_1$ . The length of taper is to be at least three times the offset.

The castings are to be cored out to avoid large masses of thick material likely to contain defects and to maintain a relatively uniform section throughout. Suitable radii are to be provided in way of changes in section.

## 3.7 Stern Frames with Shoe Piece

The scantlings below the boss of stern frames with shoe pieces are to be gradually increased to provide strength and stiffness in proportion to those of shoe pieces.

## 3.9 Scantlings Above the Propeller Boss

Above the propeller boss, the scantlings are to be in accordance with 3-2-13/3.5, except that in the upper part of the propeller aperture, where the hull form is full and centerline supports are provided, the thickness may be reduced to 80% of the requirements in 3-2-13/3.5, subject to the same minimum for a cast steel stern frame.

## 3.11 Secondary Members

Where round bars are used at the after edge of stern frames, their scantlings and connection details are to be such as will accomplish acceptable welding.

Ribs or horizontal brackets of thickness not less than  $0.8t$  or  $0.8t_1$  are to be provided at suitable intervals. Where  $t$  or  $t_1$  is reduced in accordance with 3-2-13/3.9, a proportionate reduction in the thickness of ribs or horizontal brackets may be made.

### 3.13 Shoe Pieces (1993)

The equivalent stress  $\sigma_e$  in the shoe piece at any section is not to exceed  $115/K_g$  N/mm<sup>2</sup> ( $11.7/K_g$  kgf/mm<sup>2</sup>, 16700/ $K_g$  psi) and is to be obtained from the following equation:

$$\sigma_e = n\sqrt{\sigma_b^2 + 3\tau^2} \quad \text{N/mm}^2 \text{ (kgf/mm}^2, \text{ psi)}$$

where

- $n$  = 1000 (1000, 2240)
- $K_g$  =  $K$  as defined in 3-2-14/1.3 for castings and forgings  
 = 1.0 for ordinary strength hull steel plate  
 =  $Q$  as defined in 3-2-1/5.5 for higher strength steel plate
- $\sigma_b$  = bending stress =  $0.5C_R\ell/Z_v$
- $C_R$  = rudder force, as defined in 3-2-14/3
- $\ell$  = horizontal distance between centerline of rudder stock and the particular section of the stern frame shoe piece, in m (in.) (see 3-2-13/Figure 2)
- $Z_v$  = section modulus of shoe piece about the vertical axis at the particular section under consideration, in cm<sup>3</sup> (in<sup>3</sup>)
- $\tau$  = shear stress =  $0.5C_R/A_s$
- $A_s$  = effective shear area in the transverse direction at the section of the shoe piece under consideration in, mm<sup>2</sup> (in<sup>2</sup>)

In addition, shoe piece width is to be approximately twice the depth, and vertical and horizontal section modulus and sectional area are in no case to be less than required by the following equations.

$$Z_z = k_z C_R \ell K_g \quad \text{cm}^3 \text{ (in}^3\text{)}$$

$$Z_y = 0.5Z_z \quad \text{cm}^3 \text{ (in}^3\text{)}$$

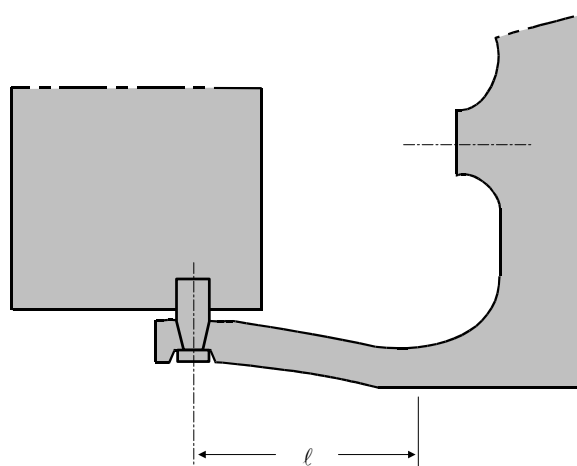
$$A_s = k_a C_R K_g \quad \text{mm}^2 \text{ (in}^2\text{)}$$

where

- $Z_z$  = minimum required section modulus of shoe piece about the vertical axis at the particular section under consideration
- $Z_y$  = minimum required section modulus of shoe piece about the transverse horizontal axis at the particular section under consideration
- $A_s$  = effective shear area in the transverse direction at the section of the shoe piece under consideration, in mm<sup>2</sup> (in<sup>2</sup>)
- $k_z$  = 6.25 (61.3, 0.0967)
- $k_a$  = 10.4 (102, 0.161)



**FIGURE 2**  
**Shoe Piece**



## 5 Rudder Horns

### 5.1 Scantlings – Single Pintle Rudders (1993)

The strength of the rudder horn is to be based on the most critical location at any point up to and in way of the connection into the hull. At no section is the equivalent stress  $\sigma_e$  in the rudder horn to exceed  $120/K_h$  N/mm<sup>2</sup> ( $12.2/K_h$  kgf/mm<sup>2</sup>,  $17400/K_h$  psi)

where  $\sigma_e$  is obtained from the following equation:

$$\sigma_e = n\sqrt{\sigma_b^2 + 3(\tau^2 + \tau_T^2)} \quad \text{N/mm}^2 \text{ (kgf/mm}^2, \text{ psi)}$$

where

$$n = 1000 \text{ (1000, 2240)}$$

$$\sigma_b = \text{bending stress} = C_R \ell_a \ell_v / (\ell_p SM)$$

$$\tau = \text{shear stress due to bending} = C_R \ell_a / (\ell_p A_h)$$

$$\tau_T = \text{shear stress due to torque} = 0.5 C_R \ell_a \ell_h / (\ell_p at)$$

$$C_R = \text{rudder force, as defined in 3-2-14/3}$$

$$\ell_a = \text{vertical distance, in m (ft), from the center of the neck bearing to the centroid of } A \text{ (see 3-2-13/Figure 3a)}$$

$$\ell_p = \text{vertical distance, in m (ft), from the center of the neck bearing to the center of the pintle bearing (see 3-2-13/Figure 3a)}$$

$$\ell_v = \text{vertical distance, in m (in.), from the center of the pintle bearing to the section of the rudder horn being considered (see 3-2-13/Figure 3a)}$$

$$\ell_h = \text{horizontal distance in, mm (in.), from the center of the pintle bearing to the center of area of the horizontal plane of the rudder horn at the section of the rudder horn being considered (see 3-2-13/Figure 3a)}$$

- $SM$  = section modulus of the rudder horn about the longitudinal axis, in  $\text{cm}^3$  ( $\text{in}^3$ ), at the section of the rudder horn being considered
- $A_h$  = effective shear area of the rudder horn in the transverse direction at the section being considered, in  $\text{mm}^2$  ( $\text{in}^2$ )
- $a$  = area, in  $\text{mm}^2$  ( $\text{in}^2$ ), enclosed by the outside lines of the rudder horn at the section of the rudder horn being considered
- $t$  = minimum wall thickness of the rudder horn, in mm (in.), at the section being considered
- $K_h$  =  $K$  as defined in 3-2-14/1.3 for castings and forgings  
 = 1.0 for ordinary strength hull steel plate  
 =  $Q$  as defined in 3-2-1/5.5 for higher strength steel plate

In addition to meeting the above maximum equivalent stress criteria, the shear stress is not to be greater than  $\tau$  indicated in the following equation.

$$\tau = 48/K_h \text{ N/mm}^2 \text{ (} 4.9/K_h \text{ kgf/mm}^2 \text{, } 6960/K_h \text{ psi)}$$

Also, the section modulus about the longitudinal horizontal axis is not to be less than given in the following equation:

$$SM = n_z C_R (\ell_a / \ell_p) \ell_v K_h \quad \text{cm}^3 \text{ (in}^3\text{)}$$

$$n_z = 14.9 \text{ (} 146.4, 0.230\text{)}$$

Webs extending down into the horn as far as practicable are to be fitted and effectively connected to the plate floors in the after peak. At the shell, the change in section of the horn is to be as gradual as possible. Generous radii are to be provided at abrupt changes of section where there are stress concentrations.

### 5.3 Scantlings – Two Pintle Rudders (1993)

The strength of the rudder horn is to meet the requirements for single pintle horns given in 3-2-13/5.1 above, with the following modified definitions of lever arm and component stresses.

- $\ell_a$  = vertical distance, in m (ft), from the center of the upper pintle to the centroid of  $A$  (see 3-2-13/Figure 3b)
- $\ell_p$  = vertical distance, in m (ft), from the center of the upper pintle bearing to the center of the lower pintle bearing (see 3-2-13/Figure 3b)
- $\ell_v$  = vertical distance, in m (in.), from the center of the lower pintle bearing to the section of the rudder horn being considered up to the entry of the horn into the shell plating (see 3-2-13/Figure 3b)
- $\ell_h$  = horizontal distance, in mm (in.), from the center of the lower gudgeon to the center of area of the horizontal plane of the rudder horn at the section of the rudder horn being considered (see 3-2-13/Figure 3b)
- $\sigma_b$  = bending stress
- =  $C_R \ell_a \ell_v / (\ell_p SM)$  between the upper and lower pintle gudgeons
- =  $C_R (\ell_v + \ell_a - \ell_p) / SM$  in SI or MKS units, above the upper pintle gudgeon
- =  $C_R [\ell_v + 12(\ell_a - \ell_p)] / SM$  in U.S. units, above the upper pintle gudgeon

$$\begin{aligned}\tau &= \text{shear stress due to bending} = C_R \ell_a / (\ell_p A_h) \text{ between the upper and lower pintle} \\ &\quad \text{gudgeons} \\ &= C_R / A_h \text{ above the upper gudgeon} \\ \tau_T &= \text{shear stress due to torque} = 0.5 C_R \ell_a \ell_h / (\ell_p a t) \text{ between the upper and lower pintle} \\ &\quad \text{gudgeons} \\ &= 0.5 C_R \ell_h / (a t) \text{ above the upper gudgeon}\end{aligned}$$

## 5.5 Floors

Heavy plate floors are to be fitted in way of the after face of the horn and in line with the webs required by 3-2-13/5.1 and 3-2-13/5.3. They may be required to be carried up to the first deck or flat.

## 5.7 Shell Plating

Heavy shell plates are to be fitted in way of the heavy plate floors required by 3-2-13/5.5. Above the heavy floors, the heavy shell plates may be reduced in thickness in as gradual a manner as practicable.

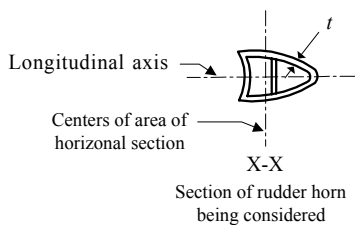
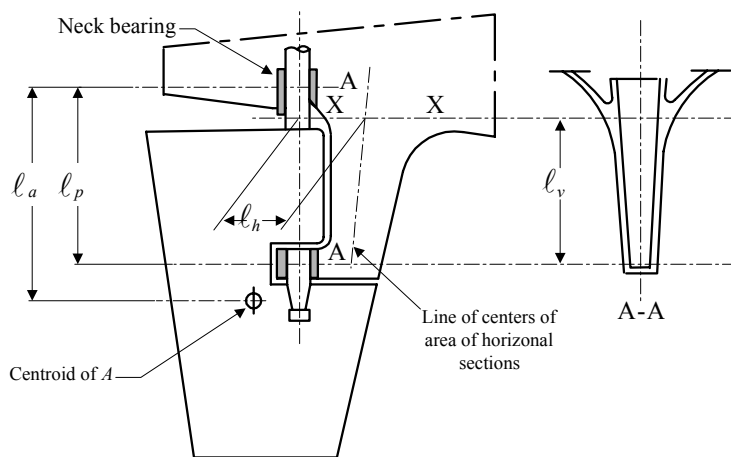
## 5.9 Water Exclusion

Rudder horns are to be provided with means for draining water, except where rudder horns are filled with an approved waterproof material, or equivalent.

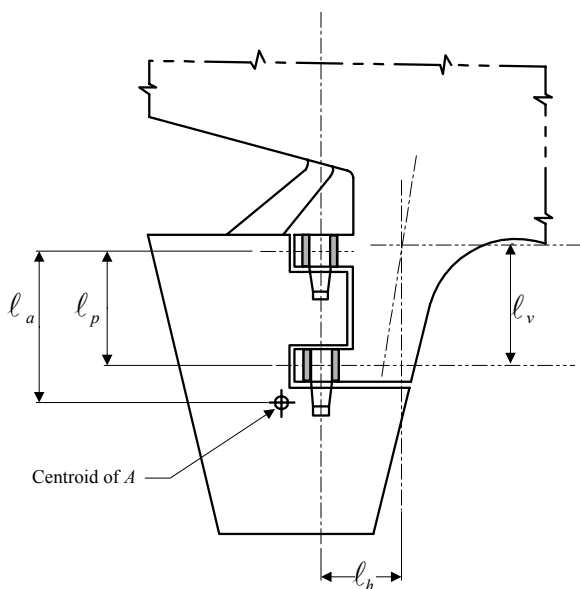
# 7 Inspection of Castings

The location of radiographic or other subsurface inspections of large stern-frame and rudder-horn castings is to be indicated on the approved plans. See applicable parts of Part 2, Chapter 1.

**FIGURE 3**  
**Rudder Horn (1993)**



a) Single Pintle



b) Two Pintles

PART

# 3

CHAPTER **2 Hull Structures and Arrangements**

SECTION **14 Rudders**

**1 General (1993)**

**1.1 Application (1993)**

The requirements of this Section apply to ordinary profile rudders. Rudders with special arrangements for increasing the rudder force, such as fins or flaps, steering propellers, or other means of steering will be subject to special consideration.

**1.3 Rudder and Rudder Stock Materials (1993)**

Rudder stocks, pintles, coupling bolts, and keys are to be of steel, in accordance with the requirements of Part 2, Chapter 1. The Surveyor need not witness material tests for coupling bolts and keys. The surfaces of rudder stocks in way of exposed bearings are to be of noncorrosive material.

Material factors for castings and forgings used for the shoe piece ( $K_g$ ), horn ( $K_h$ ), stock ( $K_s$ ), bolts ( $K_b$ ), coupling flange ( $K_f$ ), and pintles ( $K_p$ ) are to be obtained for their respective material from the following equation:

$$K = (n_y/Y)^e$$

where

$$n_y = 235 \text{ N/mm}^2 (24 \text{ kgf/mm}^2, 34000 \text{ psi})$$

$$Y = \text{specified minimum yield strength of the material, in N/mm}^2 (\text{kgf/mm}^2, \text{psi}), \text{ but is not to be taken as greater than } 0.7U \text{ or } 450 \text{ N/mm}^2 (46 \text{ kgf/mm}^2, 65000 \text{ psi}), \text{ whichever is less}$$

$$U = \text{minimum tensile strength of material used, in N/mm}^2 (\text{kgf/mm}^2, \text{psi})$$

$$e = 1.0 \text{ for } Y \leq 235 \text{ N/mm}^2 (24 \text{ kgf/mm}^2, 34000 \text{ psi})$$

$$= 0.75 \text{ for } Y > 235 \text{ N/mm}^2 (24 \text{ kgf/mm}^2, 34000 \text{ psi})$$

**1.5 Expected Torque (1993)**

The torque considered necessary to operate the rudder, in accordance with 4-3-4/21.7.1i), is to be indicated on the submitted rudder or steering gear plan. See 3-2-14/5.7 and 4-3-4/1.11.

## 1.7 Rudder Stops

Strong and effective rudder stops are to be fitted. Where adequate positive stops are provided within the gear, structural stops will not be required. See also 4-3-4/5.11.

# 3 Design Rudder Force

## 3.1 Rudders without Cutouts

The rudder force,  $C_R$ , upon which rudder scantlings are to be based is to be obtained from the following equation:

$$C_R = nk_R k_c k_\ell A V_R^2 \quad \text{kN (tf, Ltf)}$$

where

- $A$  = total projected area of rudder in,  $\text{m}^2$  ( $\text{ft}^2$ )
- $V_R$  =  $V_d$  for the ahead condition but is not to be taken as less than  $V_{\min}$   
 =  $V_a$  for the astern condition but is not to be taken as less than  $0.5V_d$  or  $0.5V_{\min}$ , whichever is greater
- $V_d$  = the design speed, in knots, with the vessel running ahead at the maximum continuous rated shaft rpm and at the summer load waterline
- $V_a$  = maximum astern speed, in knots
- $V_{\min}$  =  $(V_d + 20)/3$
- $k_R$  =  $(b^2/A_t + 2)/3$  but not more than  $4/3$  where  $b$  = mean height of rudder area, in m (ft), as determined from 3-2-14/Figure 1 or 3-2-14/Figure 2
- $A_t$  = sum of rudder blade area,  $A$ , and the rudder post or rudder horn area within the extension of the rudder profile, in  $\text{m}^2$  ( $\text{ft}^2$ )
- $k_c$  = factor dependent on rudder cross sectional shape, as indicated in 3-2-14/Table 1. For rudder sections differing from those shown in 3-2-14/Table 1,  $k_c$  will be individually considered.
- $k_\ell$  = 0.8 for rudders outside propeller jet  
 = 1.15 for rudders behind a fixed propeller nozzle  
 = 1.0 for all other rudders
- $n$  = 0.132 (0.0135, 0.00123)

### 3.3 Rudders with Cutouts

This paragraph refers to rudders whose profile cannot be adequately defined by a single quadrilateral. For rudder blades with cutouts, total rudder force is to be calculated according to 3-2-14/3.1 Rudder force distribution over the rudder area upon which rudder torque and rudder blade strength is to be based is to be derived from the following equations and from 3-2-14/Figure 2.

Rudder area may be divided into two rectangular or trapezoidal parts with areas  $A_1$  and  $A_2$  such that the sum of the areas is equal to the total area  $A$ . The resulting force on each part is to be obtained from the following equation:

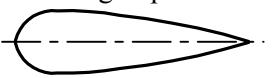
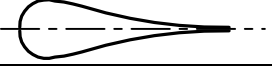
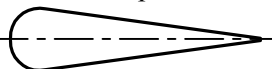
$$C_{R1} = C_R A_1 / A \quad \text{kN (tf, Ltf)}$$

$$C_{R2} = C_R A_2 / A \quad \text{kN (tf, Ltf)}$$

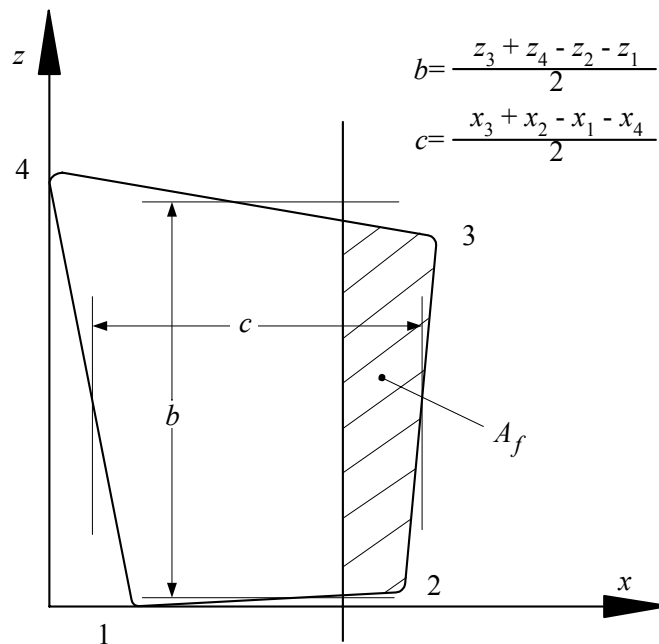
where

$C_R$  and  $A$  are as defined in 3-2-14/3.1.

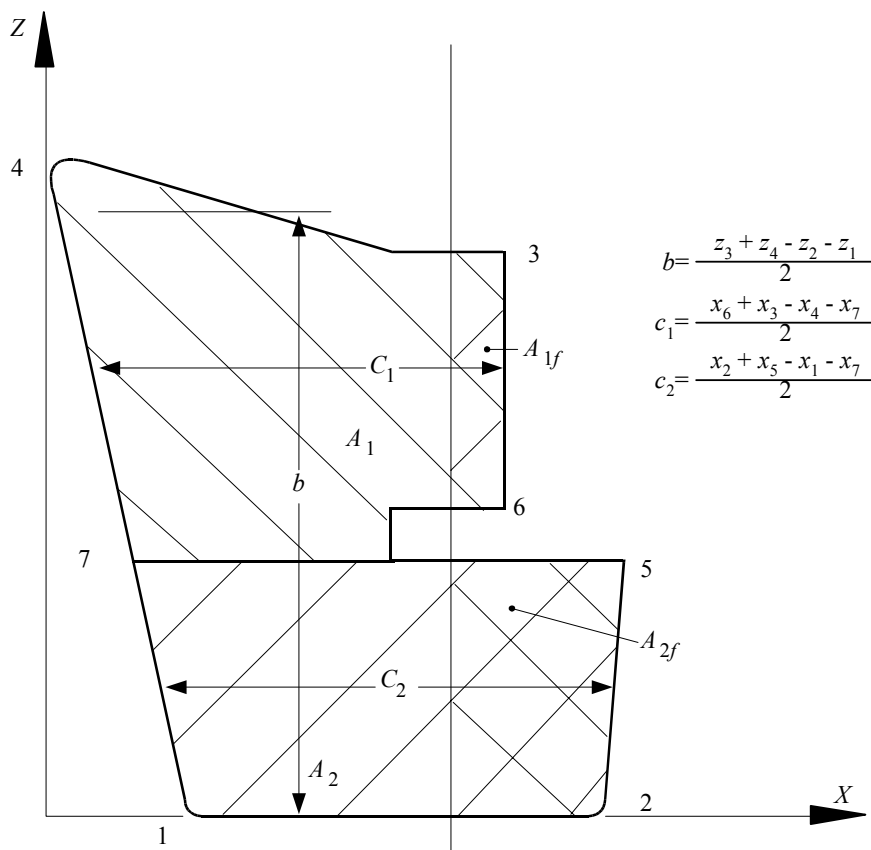
**TABLE 1**  
**Section Shape Coefficients (1993)**

<i>profile type</i>	$K_c$	
	<i>ahead condition</i>	<i>astern condition</i>
NACA-OO Gottingen-profiles 	1.1	0.80
hollow profiles 	1.35	0.90
flat side profiles 	1.1	0.90

**FIGURE 1**  
**Rudder without Cutouts (1993)**



**FIGURE 2**  
**Rudder with Cutouts (1993)**





## 5 Design Rudder Torque for Scantlings (1993)

### 5.1 General

The torque to be used in calculating rudder scantlings in accordance with these Rules is to be as defined in 3-2-14/5.3 and 3-2-14/5.5 below.

### 5.3 Rudders without Cutouts

The rudder torque is to be calculated for both the ahead and astern conditions and is to be determined from the following equation:

$$Q_R = C_R r \quad \text{kN-m (tf-m, Ltf-ft)}$$

where

$$Q_R = \text{rudder torque}$$

$$C_R = \text{rudder force as calculated in 3-2-14/3.1}$$

$$r = c(\alpha - k) \text{ (but not less than } 0.1c \text{ for ahead condition)}$$

$$c = \text{mean breadth of rudder area, in m (ft), from 3-2-14/Figure 1}$$

$$\alpha = 0.33 \text{ ahead, } 0.66 \text{ astern}$$

$$k = A_f/A$$

$$A_f = \text{area of rudder blade situated forward of the rudder stock centerline, in m}^2 \text{ (ft}^2\text{)}$$

$A$  is as defined in 3-2-14/3.1.

### 5.5 Rudders with Cutouts (1995)

This subsection refers to rudders whose profile shape cannot be adequately defined by a single quadrilateral. Total rudder torque,  $Q_R$ , in both the ahead and astern conditions is to be calculated according to the following equation:

$$Q_R = C_{R1} r_1 + C_{R2} r_2 \quad \text{kN-m (tf-m, Ltf-ft)}$$

but  $Q_R$  is not to be taken less than  $Q_{R\min}$  in the ahead condition

where

$$Q_{R\min} = 0.1C_R(A_1c_1 + A_2c_2)/A$$

$$r_1 = c_1(\alpha - k_1) \text{ m (ft)}$$

$$r_2 = c_2(\alpha - k_2) \text{ m (ft)}$$

$$c_1, c_2 = \text{mean breadth of partial area } A_1, A_2, \text{ from 3-2-14/Figure 2}$$

$$\alpha = 0.33 \text{ ahead, } 0.66 \text{ astern for portions of the rudder without fixed structures forward}$$

$$= 0.25 \text{ ahead, } 0.55 \text{ astern for portions of the rudder behind fixed structures such as horns}$$

$$k_1, k_2 = A_{1f}/A_1, A_{2f}/A_2 \text{ where } A_{1f}, A_{2f} = \text{area of rudder blade situated forward of the centerline of the rudder stock for each part of the rudder}$$

$A_1, A_2, C_{R1}, C_{R2}$  are as defined in 3-2-14/3.3.

## 5.7 Trial Conditions

Above equations for  $Q_R$  are intended for the design of rudders and should not be directly compared with the torque expected during the trial (see 3-2-14/1.5) or the rated torque of steering gear (see 4-3-4/1.11).

## 7 Rudder Stocks (1993)

### 7.1 Upper Rudder Stocks (1993)

The upper stock is that part of the rudder stock above the neck bearing or above the top pintle, as the case may be.

At the upper bearing or tiller, the upper stock diameter is not to be less than obtained from the following equation:

$$S = N_u \sqrt[3]{Q_R K_s} \quad \text{mm (in.)}$$

where

$$N_u = 42.0 \text{ (89.9, 2.39)}$$

$$Q_R = \text{total rudder torque, as defined in 3-2-14/5, in kN-m (tf-m, Ltf-ft)}$$

$$K_s = \text{material factor for upper rudder stock, as defined in 3-2-14/1.3}$$

### 7.3 Lower Rudder Stocks (1993)

In determining lower rudder stock scantlings, rudder force and torque values calculated in 3-2-14/3 and 3-2-14/5 are to be used. Bending moments, shear forces and torques as well as the reaction forces are to be determined by direct calculation. Calculations for moments, shear forces and reaction forces are to be submitted. For rudders supported by shoe pieces or rudder horns, these structures are to be included in the calculation model to account for support of the rudder body. Guidance for calculation of these values is given in Appendix 3-2-A5.

The lower rudder stock diameter is not to be less than obtained from the following equation:

$$S_l = S \sqrt[6]{1 + (4/3)(M/Q_R)^2} \quad \text{mm (in.)}$$

where

$$S = \text{upper stock required diameter from 3-2-14/7.1, in mm (in.)}$$

$$M = \text{bending moment at the station of the rudder stock considered, in kN-m (tf-m, Ltf-ft)}$$

$$Q_R = \text{rudder torque from 3-2-14/5, in kN-m (tf-m, Ltf-ft)}$$

Above the neck bearing, a gradual transition is to be provided where there is a change in the diameter of the rudder stock.

## 9 Flange Couplings (1993)

### 9.1 General

Rudder couplings are to be supported by an ample body of metal worked out from the rudder stock. The material outside the bolt holes is not to be less than two-thirds the diameter of the bolt. Suitable means of locking the nuts are to be provided. The coupling bolts are to be fitted bolts. The diameter of the bolts and the flange thickness are not to be less than obtained from the following equations:

### 9.3 Horizontal Couplings

There are to be at least six coupling bolts in horizontal couplings, and the diameter of each bolt is not to be less than obtained by the following equation:

$$d_b = 0.62 \sqrt{d_s^3 K_b / (nr K_s)} \quad \text{mm (in.)}$$

where

- $d_b$  = bolt diameter
- $n$  = total number of bolts in coupling
- $r$  = mean distance, in mm (in.), of the bolt centers from the center of the system of bolts
- $d_s$  = required diameter of stock in way of coupling,  $S$  or  $S_\ell$  from 3-2-14/7.1 or 3-2-14/7.3, as the case may be, in mm (in.)
- $K_b$  = material factor for bolts, as defined in 3-2-14/1.3
- $K_s$  = material factor for stock, as defined in 3-2-14/1.3

Coupling flange thickness is not to be less than the greater of the following equations:

$$t_f = d_b \sqrt{K_f / K_b} \quad \text{mm (in.)}$$

$$t_f = 0.9 d_b \quad \text{mm (in.)}$$

where

- $K_f$  = material factor for flange, as defined in 3-2-14/1.3
- $d_b$  = required bolt diameter calculated for a number of bolts not exceeding 8

### 9.5 Vertical Couplings

There are to be at least eight coupling bolts in vertical couplings and the diameter of each bolt is not to be less than obtained from the following equation:

$$d_b = 0.81 d_s \sqrt{K_b / (n K_s)}$$

where

- $n$  = total number of bolts

$d_s, K_b, K_s$  as defined above

In addition, the first moment of area of the bolts about the center of the coupling is not to be less than given by the following equation:

$$m = 0.00043 d_s^3 \text{ mm}^3 \text{ (in}^3\text{)}$$

where

- $m$  = first moment of area
- $d_s$  = diameter, as defined in 3-2-14/9.3

Coupling flange thickness is not to be less than  $d_b$ .

## 11 Tapered Stock Couplings (1993)

### 11.1 Taper Ratio

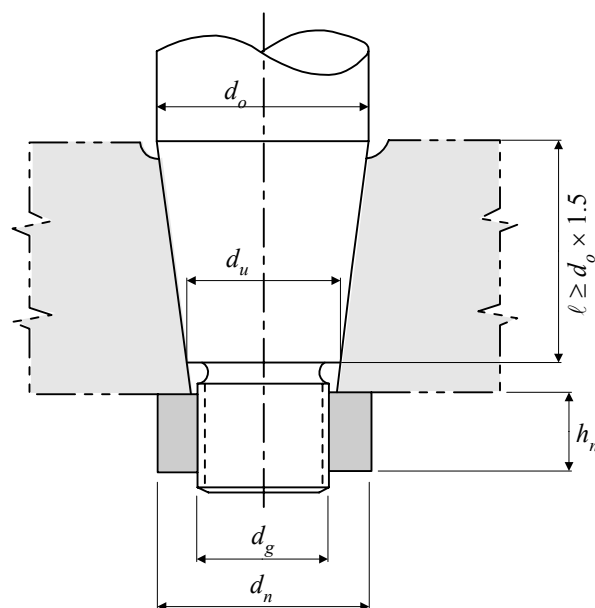
Tapered stocks secured to the rudder casting by a nut on the end of the stock are to have a length of taper in the casting generally not less than 1.5 times the diameter of the stock at the top of the rudder. Couplings without hydraulic arrangements for mounting and dismounting the coupling should have a taper on diameter of 1/8 to 1/12. For couplings with hydraulic arrangements for mounting and dismounting the coupling (mounting with oil injection and hydraulic nut), the taper on diameter should be 1/12 to 1/20, and the push-up oil pressure and the push-up length will be specially considered upon submission of calculations in each case.

### 11.3 Keying

Where the stock is keyed to the rudder casting, torsional strength equivalent to that of the required upper stock diameter is to be provided. The top of the keyway is to be located well below the top of the rudder.

For higher strength materials, shear and bearing areas of keys and keyways are to be based on the strength properties of the key and the materials in which keyways are cut, as appropriate.

**FIGURE 3**  
**Tapered Couplings (1993)**



### 11.5 Locking Nut

The nut is to be proportioned in accordance with the following and is to be fitted with an effective locking device.

External thread diameter  $d_g \geq 0.65d_o$

Length of nut  $h_n \geq 0.6d_g$

Outer diameter of nut  $d_n \geq 1.2d_u$  or  $1.5d_g$  whichever is greater

See 3-2-14/Figure 3.

## 13 Keyless Couplings

Hydraulic and shrink fit keyless couplings will be specially considered upon submittal of detailed preloading and stress calculations and fitting instructions. The calculated torsional holding capacity is to be at least 2.0 times the transmitted torque based on the steering gear relief valve setting. Preload stress is not to exceed 70% of the minimum yield strength.

## 15 Pintles (1995)

### 15.1 General

Pintles are to have a conical attachment to the gudgeons with a taper on diameter of:

1/8 to 1/12 for keyed and other manually assembled pintles applying locking by locking nut.

1/12 to 1/20 on diameter for pintle mounted with oil injection and hydraulic nut.

The diameter of the pintles is not to be less than obtained from the following equation.

$$d_p = k_1 \sqrt{BK_p} \quad \text{mm (in.)}$$

where

$$k_1 = 11.1 \quad (34.7, 1.38)$$

$$B = \text{bearing force, in kN (tf, Ltf), to be obtained by direct calculation which is to be submitted, but is to be taken as not less than the following.}$$

Type		$B_{\min}$
Conventional two pintle rudder		$0.5 C_R$
3-2-A5/Figure 2	lower pintle	$0.5 C_R$
3-2-A5/Figure 3	main pintle	$C_R \ell_a / \ell_p^*$
3-2-13/Figure 3	main pintle	$C_R \ell_a / \ell_p^*$
	upper pintle	$0.25 C_R$

$$*B_{\min} = C_R \text{ where } C_R \ell_a / \ell_p \geq C_R$$

$$K_p = \text{material factor for the pintle, as defined in 3-2-14/1.3}$$

Threads and nuts are to be in accordance with 3-2-14/11.5.

The depth of the pintle boss is not to be less than  $d_p$ . In addition, the bearing length of the pintle is to be between 1.0 and 1.2 times the pintle diameter. The bearing pressure is to be in accordance with 3-2-14/17.1.

For rudders on horns with two pintles, as shown in 3-2-13/Figure 3b, calculations are to include pintle bearing forces with the vessel running ahead at the maximum continuous rated shaft rpm and at the lightest operating draft.

## 17 Supporting and Anti-Lifting Arrangements (1993)

### 17.1 Rudder Stock and Pintle Bearings (1993)

#### 17.1.1 Bearing Surfaces

The length/diameter ratio of the bearing surface is not to be greater than 1.2, and the bearing surface  $A_b$  for rudder stocks, shafts and pintles is not to be less than obtained from the following equation:

$$A_b = 1000P/q_a \quad \text{mm}^2$$

$$A_b = 2240P/q_a \quad \text{in}^2$$

where

$A_b$  = projected area of bearing surface =  $d_l \ell_b$  where  $d_l$  is the outer diameter of the liner and  $\ell_b$  is the bearing length

$P$  = bearing reaction force, in kN (tf, Ltf). For pintle bearings, this is to be taken as  $B$ , as defined in 3-2-14/15.

Reaction forces at other bearings are to be obtained by direct calculation, which is to be submitted. Guidance for calculation is given in Appendix 3-2-A5.

$q_a$  = allowable surface pressure, as indicated in 3-2-14/Table 2 depending on bearing material, in N/mm<sup>2</sup> (kgf/mm<sup>2</sup>, psi)

#### 17.1.2 Bearing Clearance

With metal bearings, the clearance is not to be less than  $d_i/1000 + 1.0$  mm ( $d_i/1000 + 0.04$  in.) on the diameter, where  $d_i$  is the inner diameter of the bushing, in mm (in.). If non-metallic bearing material is applied, the bearing clearance is to be specially determined considering the material's swelling and thermal expansion properties. This clearance is in no case to be taken less than 1.5 mm (0.06 in.) on diameter.

### 17.3 Rudder Carrier (1997)

The weight of the rudder assembly is to be supported by a rudder carrier mounted on the hull structure designed for that purpose. At least half of the rudder carrier holding-down bolts are to be fitted bolts. Alternative means of preventing horizontal movement of the rudder carrier may be considered.

### 17.5 Anti-lifting Devices (1997)

Means are to be provided to prevent accidental unshipping or undue movement of the rudder which may cause damage to the steering gear. There are to be at least two bolts in the joint of the anti-lifting ring.

**TABLE 2**  
**Bearing Pressure**

Bearing Material	$q_a$ †		
	$N/mm^2$	$kgf/mm^2$	psi
lignum vitae	2.5	0.25	360
white metal, oil lubricated	4.5	0.46	650
synthetic material with hardness between 60 and 70 Shore D *	5.5	0.56	800
steel § and bronze and hot-pressed bronze-graphite materials	7.0	0.71	1000

§ Stainless and wear-resistant steel in an approved combination with stock liner.

† Higher values than given in the table may be taken if they are verified by tests.

\* Indentation hardness test at 23°C and with 50% moisture, according to a recognized standard. Synthetic bearing materials to be of approved type.

## 19 Double Plate Rudder (1993)

### 19.1 Strength (1993)

Rudder section modulus and web area are to be such that stresses indicated below are not exceeded.

In calculating the section modulus of the rudder, the effective width of side plating is to be taken as not greater than twice the athwartship dimension of the rudder. Welded or bolted cover plates on access openings to pintles are not to be considered effective in determining the section modulus of the rudder. Generous radii are to be provided at abrupt changes in section where there are stress concentrations.

Moments, shear forces and reaction forces are to be obtained by direct calculation, which is to be submitted. Guidance for calculation of these values is given in Appendix 3-2-A5.

#### 19.1.1 Clear of Cutouts (1999)

Bending stress  $\sigma_b$  110/ $Q$   $N/mm^2$  (11.2/ $Q$   $kgf/mm^2$ , 15,900/ $Q$  psi)

Shear stress  $\tau$  50/ $Q$   $N/mm^2$  (5.1/ $Q$   $kgf/mm^2$ , 7300/ $Q$  psi)

Equivalent stress  $\sigma_e = \sqrt{\sigma_b^2 + 3\tau^2}$  120/ $Q$   $N/mm^2$  (12.2/ $Q$   $kgf/mm^2$ , 17,400/ $Q$  psi)

#### 19.1.2 In way of Cutouts (See 3-2-14/Figure 4) (1999)

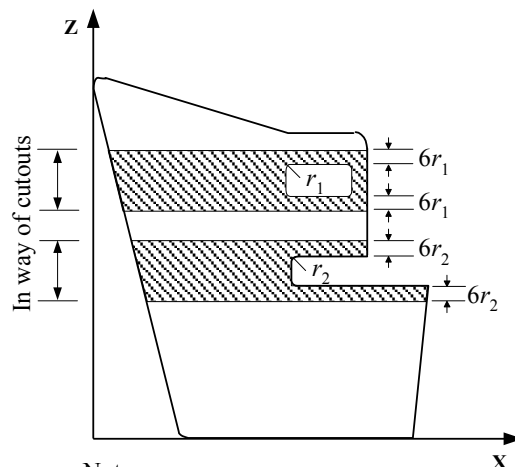
Bending stress  $\sigma_b$  75/ $Q$   $N/mm^2$  (7.65/ $Q$   $kgf/mm^2$ , 10,900/ $Q$  psi)

Shear stress  $\tau$  50/ $Q$   $N/mm^2$  (5.1/ $Q$   $kgf/mm^2$ , 7300/ $Q$  psi)

Equivalent stress  $\sigma_e = \sqrt{\sigma_b^2 + 3\tau^2}$  100/ $Q$   $N/mm^2$  (10.2/ $Q$   $kgf/mm^2$ , 14,500/ $Q$  psi)

$Q$  = 1.0 for ordinary strength hull steel  
 = as defined in 3-2-1/5.5 for higher strength steel plate

FIGURE 4



Note:  
 $r_1$  = corner radius of rudder plate in way of portable bolted inspection hole  
 $r_2$  = corner radius of rudder plate

For spade rudders and rudders with horns, the section modulus at the bottom of the rudder is not to be less than one-third the required section modulus of the rudder at the top of the rudder or at the center of the lowest pintle.

Rudders of unsymmetrical shape are to have lower stocks, as required by 3-2-14/7.3, and details are to be submitted.

### 19.3 Side, Top and Bottom Plating

The plating thickness is not to be less than obtained from the following equation:

$$t = 0.0055 s \beta \sqrt{k_1 d + (k_2 C_R / A)} \times \sqrt{Q} + k_3 \quad \text{mm (in.)}$$

where

- $Q$  = 1.0 for ordinary strength hull steel  
 = as defined in 3-2-1/5.5 for higher strength steel plate
- $k_1$  = 1.0 (1.0, 0.305)
- $k_2$  = 0.1 (0.981, 10.7)
- $k_3$  = 2.5 (2.5, 0.1)
- $d$  = summer loadline draft of the vessel, in m (ft)
- $C_R$  = rudder force according to 3-2-14/3, in kN (tf, Ltf)
- $A$  = rudder area, in  $\text{m}^2$  ( $\text{ft}^2$ )
- $\beta$  =  $\sqrt{1.1 - 0.5(s/b)^2}$  maximum 1.0 for  $b/s \geq 2.5$
- $s$  = smaller unsupported dimension of plating, in mm (in.)
- $b$  = greater unsupported dimension of plating, in mm (in.)

The thickness of the rudder side or bottom plating is to be at least 2 mm (0.08 in.) greater than that required by 3-2-10/3.1 for deep tank plating in association with a head  $h$  measured to the summer load line.



## 19.5 Diaphragm Plates

Vertical and horizontal diaphragms are to be fitted within the rudder, effectively attached to each other and to the side plating. Vertical diaphragms are to be spaced approximately 1.5 times the spacing of horizontal diaphragms.

The thickness of diaphragm plates is not to be less than 70% of the required rudder side plate thickness or 8 mm (0.31 in.), whichever is greater. Openings in diaphragms are not to exceed one half their depth.

Welding is to be in accordance with Section 2-4-1 and Section 3-2-19. Where inaccessible for welding inside the rudder, it is recommended that diaphragms be fitted with flat bars and the side plating be connected to these flat bars by continuous welds or by 75 mm (3 in.) slot welds spaced at 150 mm (6 in.) centers.

## 19.7 Watertightness

The rudder is to be watertight and is to be tested in accordance with 3-7-1/Table 1.

## 21 Single Plate Rudders (1993)

### 21.1 Mainpiece Diameter (1993)

The mainpiece diameter is calculated according to 3-2-14/7.3. For spade rudders, the lower third may be tapered down to 0.75 times stock diameter at the bottom of the rudder.

### 21.3 Blade Thickness (1993)

The blade thickness is not to be less than obtained from the following equation:

$$t_b = 0.0015sV_R + 2.5 \quad \text{mm}$$

$$t_b = 0.0015sV_R + 0.1 \quad \text{in.}$$

where

$s$  = spacing of stiffening arms, in mm (in.), not to exceed 1000 mm (39 in.)

$V_R$  = speed, as defined in 3-2-14/3

### 21.5 Arms (1993)

The thickness of the arms is not to be less than the blade thickness obtained in 3-2-14/21.3. The section modulus of each set of arms about the axis of the rudder stock is not to be less than obtained from the following equation:

$$SM = 0.0005sC_1^2V_R^2Q \quad \text{cm}^3$$

$$SM = 0.0000719sC_1^2V_R^2Q \quad \text{in}^3$$

where

$C_1$  = horizontal distance from the aft edge of the rudder to the centerline of the rudder stock, in m (ft)

$Q$  = 1.0 for ordinary strength hull steel

= as defined in 3-2-1/5.5 for higher strength steel plate

$s$ ,  $V_R$  are as defined in section 3-2-14/21.3.

This Page Intentionally Left Blank

PART

# 3

CHAPTER **2 Hull Structures and Arrangements**

APPENDIX **5 Guidelines for Calculating Bending Moment and Shear Force in Rudders and Rudder Stocks (1993)**

## 1 Application

Bending moments, shear forces and reaction forces of rudders, stocks and bearings may be calculated according to this Appendix for the types of rudders indicated. Moments and forces on rudders of different types or shapes than those shown are to be calculated using alternative methods and will be specially considered.

## 3 Spade Rudders

### 3.1 Rudder

#### 3.1.1 Shear Force

Lateral shear force,  $V(z)$ , at a horizontal section of the rudder  $z$  meters (feet) above the bottom of  $\ell_R$  is given by the following equation:

$$V(z) = \frac{zC_R}{A} \left[ c_\ell + \frac{z}{2\ell_R} (c_u - c_\ell) \right] \quad \text{kN (tf, Ltf)}$$

where

$z$  = distance from the bottom of  $\ell_R$  to the horizontal section under consideration, in m (ft)

$C_R$  = rudder force, as defined in 3-2-14/3, in kN (tf, Ltf)

$A$  = rudder blade area, in m<sup>2</sup> (ft<sup>2</sup>)

$c_\ell$ ,  $c_u$  and  $\ell_R$  are dimensions as indicated in 3-2-A5/Figure 1, in m (ft).

### 3.1.2 Bending Moment

Bending moment,  $M(z)$ , at a horizontal section  $z$  meters (feet) above the baseline of the rudder is given by the following equation:

$$M(z) = \frac{z^2 C_R}{2A} \left[ c_\ell + \frac{z}{3\ell_R} (c_u - c_\ell) \right] \quad \text{kN-m, (tf-m, Ltf-ft)}$$

where  $z$ ,  $C_R$ ,  $A$ ,  $c_\ell$ ,  $c_u$  and  $\ell_R$  are as defined in 3-2-A5/3.1.1.

## 3.3 Lower Stock

### 3.3.1 Shear Force

Lateral shear force at any section of the lower stock between the top of the rudder and the neck bearing,  $V_\ell$ , is given by the following equation:

$$V_\ell = C_R \quad \text{kN (tf, Ltf)}$$

where  $C_R$  is as defined in 3-2-A5/3.1.1

### 3.3.2 Bending Moment at Neck Bearing

The bending moment in the rudder stock at the neck bearing,  $M_n$ , is given by the following equation:

$$M_n = C_R \left[ \ell_\ell + \frac{\ell_R (2c_\ell + c_u)}{3(c_\ell + c_u)} \right] \quad \text{kN-m (tf-m, Ltf-ft)}$$

where

$$C_R = \text{rudder force as defined in 3-2-A5/3.1.1}$$

$c_\ell$ ,  $c_u$ ,  $\ell_\ell$  and  $\ell_R$  are dimensions as indicated in 3-2-A5/Figure 1, in m (ft).

## 3.5 Moment at Top of Upper Stock Taper

The bending moment in the upper rudder stock at the top of the taper,  $M_t$ , is given by the following equation:

$$M_t = C_R \left[ \ell_\ell + \frac{\ell_R (2c_\ell + c_u)}{3(c_\ell + c_u)} \right] \times \left[ \frac{(\ell_u + \ell_R + \ell_\ell - z_t)}{\ell_u} \right] \quad \text{kN-m (tf-m, Ltf-ft)}$$

where

$$z_t = \text{distance from the rudder baseline to the top of the upper rudder stock taper in m (ft)}$$

$$C_R = \text{rudder force, as defined in 3-2-A5/3.1.1}$$

$c_\ell$ ,  $c_u$ ,  $\ell_\ell$ ,  $\ell_u$  and  $\ell_R$  are dimensions as indicated in 3-2-A5/Figure 1, in m (ft).



## 5 Rudders Supported by Shoe Piece

### 5.1 Shear Force, Bending Moment and Reaction Forces

Shear force, bending moment and reaction forces may be calculated according to the model given in 3-2-A5/Figure 2.

$$w_R = \text{rudder load per unit length}$$

$$= \frac{C_R}{\ell_R} \quad \text{kN/m (tf/m, Ltf/ft)}$$

where

$$C_R = \text{rudder force, as defined in 3-2-14/3}$$

$$k_s = \text{spring constant reflecting support of the shoe piece}$$

$$= \frac{n_s I_s}{\ell_s^3} \quad \text{kN/m (tf/m, Ltf/ft)}$$

$$n_s = 6.18 \text{ (0.630, 279)}$$

$$I_s = \text{moment of inertia of shoe piece about the vertical axis, in cm}^4 \text{ (in}^4\text{)}$$

$$I_u = \text{moment of inertia of the rudder stock above the neck bearing, in cm}^4 \text{ (in}^4\text{)}$$

$$I_\ell = \text{moment of inertia of the rudder stock below the neck bearing, in cm}^4 \text{ (in}^4\text{)}$$

$$I_R = \text{moment of inertia of the rudder about the longitudinal axis, in cm}^4 \text{ (in}^4\text{)}$$

$$I_p = \text{moment of inertia of the pintle, in cm}^4 \text{ (in}^4\text{)}$$

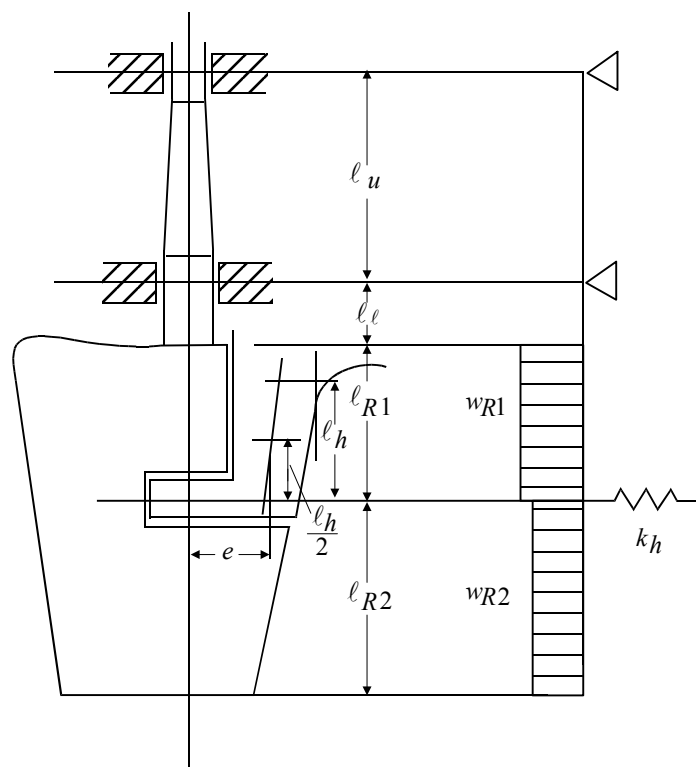
$\ell_\ell$ ,  $\ell_s$ ,  $\ell_R$  and  $\ell_u$  are dimensions as indicated in 3-2-A5/Figure 2, in m (ft).



- $k_h$  = spring constant reflecting support of the horn  
 =  $\frac{1}{\frac{\ell_h^3}{n_b I_h} + \frac{\sum \left( \frac{s_i}{t_i} \right) e^2 \ell_h}{n_t a^2}}$  kN/m (tf/m, Ltf/ft)  
 $n_b$  = 4.75 (0.485, 215)  
 $n_t$  = 3.17 (0.323, 143)  
 $a$  = mean area enclosed by the outside lines of the rudder horn, in cm<sup>2</sup> (in<sup>2</sup>)  
 $s_i$  = the girth length of each segment of the horn of thickness  $t_i$ , in cm (in.)  
 $t_i$  = the thickness of each segment of horn outer shell of length  $s_i$ , in cm (in.)  
 $I_h$  = moment of inertia of horn section at  $\ell_h$  about the longitudinal axis, in cm<sup>4</sup> (in<sup>4</sup>)  
 $I_u$  = moment of inertia of the rudder stock above the neck bearing, in cm<sup>4</sup> (in<sup>4</sup>)  
 $I_\ell$  = moment of inertia of the rudder stock below the neck bearing, in cm<sup>4</sup> (in<sup>4</sup>)  
 $I_{R1}$  = moment of inertia of the portion of the rudder above the pintle about the longitudinal axis, in cm<sup>4</sup> (in<sup>4</sup>)

$e, \ell_\ell, \ell_h, \ell_{R1}, \ell_{R2}$  and  $\ell_u$  are dimensions as indicated in 3-2-A5/Figure 3, in m (ft)

**FIGURE 3**  
**Rudder Supported by a Horn with One Pintle**





**1 General**

All openings in decks are to be framed to provide efficient support and attachment to the ends of the half beams. The following Rules relate to vessels having minimum freeboards. Where the draft is less than that corresponding to the minimum freeboard, or for decks above the first deck above the freeboard deck, the heights of the coamings and the effectiveness of the closing arrangements may be modified. The proposed arrangements and details for all hatchways are to be submitted for approval.

**3 Positions and Design Pressures (1 January 2005)****3.1 Positions of Deck Openings (1 January 2005)**

For the purpose of the Rules, two positions of deck openings are defined as follows.

*Position 1* Upon exposed freeboard and raised quarter decks, and upon exposed superstructure decks situated forward of a point located  $L_f/4$  from the forward end of  $L_f$ .

*Position 2* Upon exposed superstructure decks situated abaft  $L_f/4$  from the forward end of  $L_f$  and located at least one standard height of superstructure above the freeboard deck. Upon exposed superstructures decks situated forward of a point located  $L_f/4$  from the forward end of  $L_f$  and located at least two standards heights of superstructure above the freeboard deck.

**3.3 Design Pressures (1 January 2005)**

The design pressures are not to be taken as less than the following. Values at intermediate lengths are to be determined by interpolation.

**3.3.1 Cargo Hatch Covers in Position 1**

*For ships of 100 m (328 ft) in length and above:*

$$p = p_0 + (p_{FP} - p_0)(0.25 - x/L_f)/0.25 \quad \text{kN/m}^2 \text{ (tf/m}^2, \text{ Ltf/ft}^2)$$

*For ships less than 100 m (328 ft) in length:*

$$p = R\{15.8 + (L_f/N)[1 - (5/3)(x/L_f)] - 3.6x/L_f\} \quad \text{kN/m}^2 \text{ (tf/m}^2, \text{ Ltf/ft}^2)$$

For a position 1 hatchway located at least one superstructure standard height higher than the freeboard deck:

$$p = 3.5 - 1.5x \frac{(100 - L_{f1})}{76} \quad \text{kN/m}^2 \text{ (tf/m}^2, \text{ Ltf/ft}^2)$$

where

$$\begin{aligned}
 p_0 &= 34.3 \text{ (3.5, 0.32)} \quad \text{kN/m}^2 \text{ (tf/m}^2, \text{ Ltf/ft}^2) \\
 p_{FP} &= \text{pressure at the forward perpendicular} \\
 &= 49.0 + a(L_f - 100) \quad \text{kN/m}^2 \text{ for } L_f \text{ in meters} \\
 &= 5 + a(L_f - 100) \quad \text{tf/m}^2 \text{ for } L_f \text{ in meters} \\
 &= 0.457 + a(L_f - 328) \text{ Ltf/ft}^2 \text{ for } L_f \text{ in feet} \\
 a &= 0.0726 \text{ (0.0074, 0.000206)} \quad \text{kN/m}^2 \text{ (tf/m}^2, \text{ Ltf/ft}^2), \text{ for type B freeboard ships} \\
 &= 0.356 \text{ (0.0363, 0.00101)} \quad \text{kN/m}^2 \text{ (tf/m}^2, \text{ Ltf/ft}^2), \text{ for ships with reduced freeboard} \\
 L_f &= \text{freeboard length, in m (ft), as defined in 3-1-1/3.3, but is not to be taken as greater than 340 m (1115 ft)} \\
 L_{f1} &= \text{freeboard length, in m (ft), as defined in 3-1-1/3.3, but is not to be taken as greater than 150 m (325 ft) and less than 90 m (295 ft)} \\
 x &= \text{distance, in m (ft), from the mid length of the hatch cover under examination to the forward end of } L_f \text{ or } 0.25L_f \text{ whichever is less.} \\
 R &= 1.0 \text{ (0.102, 0.00932)} \\
 N &= 3 \text{ (3, 9.84)}
 \end{aligned}$$

### 3.3.2 Cargo Hatch Covers in Position 2

Where a position 2 hatchway is located at least one superstructure standard height higher than the freeboard deck, the pressure  $p$  may be  $25.5 \text{ kN/m}^2$  ( $2.60 \text{ tf/m}^2$ ,  $0.238 \text{ Ltf/ft}^2$ ) for vessel's  $L_f$   $100 \text{ m}$  ( $328 \text{ ft}$ ) and greater. Where vessel's  $L_f$  is less than  $100 \text{ m}$  the design pressures are as follows:

$$\begin{aligned}
 p &= 25.5 - 0.142(100 - L_f) \quad \text{kN/m}^2 \\
 &= 2.6 - 0.0145(100 - L_f) \quad \text{tf/m}^2 \\
 &= 0.238 - 0.00041(328 - L_f) \quad \text{Ltf/ft}^2
 \end{aligned}$$

## 5 Hatchway Coamings

### 5.1 Height of Coamings

The height of coamings of hatchways secured weathertight by tarpaulins and battening devices is to be at least as follows.

600 mm (23.5 in.) if in Position 1

450 mm (17.5 in.) if in Position 2

Where hatch covers are made of steel or other equivalent material and made tight by means of gaskets and clamping devices, these heights may be reduced, or the coamings omitted entirely, provided that the safety of the vessel is not thereby impaired in any sea condition.

### 5.3 Coaming Plates

Coaming plates are not to be less than 11 mm (0.44 in.) thick.

### 5.5 Coaming Stiffening

Horizontal stiffeners are to be fitted on coamings in Position 1; they are to be not more than 254 mm (10 in.) below the upper edge of the coaming. The breadth of the stiffeners is not to be less than 175 mm (7 in.). Effective brackets or stays are to be fitted from the stiffeners to the deck at intervals of not more than 3 m (10 ft). All exposed coamings other than Position 1 which are 760 mm (30 in.) or more in height are to be similarly supported. Where the height of any exposed coaming exceeds 915 mm (36 in.), the arrangement of the stiffeners and brackets or stays is to be such as to provide equivalent support. Where end coamings are protected, the arrangement of the stiffeners and brackets or stays may be modified.

Where chocks are provided on the coaming to limit the horizontal movement of the hatch cover, the strength of the coaming and deck structure is to be adequate to withstand the load on these chocks. Similar consideration is to be given to pads supporting the weight from hatch covers.

### 5.7 Protection of Coaming Edges

Heavy convex moldings are to be fitted at the upper edges of all exposed coamings of hatches sealed by tarpaulins and battens, as protection against chafing as well as damage to the coaming. The lower edge of the coaming is to be flanged or provided with other suitable protection against damage unless the spaces served by the hatchway are intended exclusively for specialized cargoes such as containers.

### 5.9 Continuous Longitudinal Hatch Coamings

Where strength deck longitudinal hatch coamings of length greater than  $0.14L$  are effectively supported by longitudinal bulkheads or deep girders, as indicated in 3-2-1/13, they are in general to be longitudinally stiffened. The coaming thickness is to be not less than required by 3-2-3/Table 2, equation 2b, and the longitudinal stiffeners not less than required by 3-2-7/3.1 for strength deck longitudinal beams; where  $s$  is the spacing of the stiffeners,  $\ell$  is the distance between coaming brackets and  $h$  is as given in column b of 3-2-7/Table 1. Special consideration will be given to the coaming scantlings where adequate buckling strength is shown to be otherwise provided.

## 7 Hatchways Closed by Portable Covers and Secured Weathertight by Tarpaulins and Battening Devices (1997)

### 7.1 Pontoon Covers

#### 7.1.1 Scantlings (*1 January 2005*)

Where steel pontoon covers are used in place of portable beams and covers, the maximum allowable stress and deflection under the design pressures in 3-2-15/3.3, and the minimum required top plate thickness are as follows.

Maximum allowable stress	$0.68Y$
Maximum allowable deflection	0.0044 times the span
Top plate thickness	0.01s, but not less than 6 mm (0.24 in.)

where

$Y$	=	specified minimum upper yield point strength of the materials, in N/mm <sup>2</sup> (kgf/mm <sup>2</sup> , psi)
$s$	=	stiffener spacing

Covers are to be assumed to be simply supported.

Where the cross section of hatch cover stiffeners is not constant along the span, Appendix 3-2-A6 may be used to determine required scantlings.

#### 7.1.2 Cleats

Cleats are to be set to fit the taper of the wedges. They are to be at least 65 mm (2.5 in.) wide and spaced not more than 600 mm (23.5 in.) center to center. The cleats along each side or end are to be not more than 150 mm (6 in.) from the hatch corners.

#### 7.1.3 Wedges

Wedges are to be of tough wood; they are to have a taper of not more than 1 in 6 and are to be not less than 13.0 mm (0.50 in.) thick at the toes.

#### 7.1.4 Battening Bars

Battening bars are to be provided for properly securing the tarpaulins; they are to have a width of 64 mm (2.5 in.) and a thickness of not less than 9.5 mm (0.375 in.).

#### 7.1.5 Tarpaulins

At least two tarpaulins thoroughly waterproofed and of ample strength are to be provided for each exposed hatchway. The material is to be guaranteed free from jute and is to be of an approved type. Synthetic fabrics which have been demonstrated to be equivalent will be specially approved

#### 7.1.6 Security of Hatch Covers

For all hatchways in Position 1 or 2, steel bars or other equivalent means are to be provided in order to efficiently and independently secure each section of hatch covers after the tarpaulins are battened down. Hatch covers of more than 1.5 m (4.9 ft) in length are to be secured by at least two such securing appliances.

## 7.3 Wood Hatch Covers

### 7.3.1 Hatch Boards

Wood hatch covers on exposed hatchways are to have a finished thickness not less than 60 mm (2.375 in.), where the span is not more than 1.5 m (4.9 ft). The wood is to be of satisfactory quality, straight-grained, reasonably free from knots, sap and shakes, and is to be examined before being coated. Hatch rests are to be beveled where necessary, so as to provide a solid bearing surface.

### 7.3.2 Portable Beams (*1 January 2005*)

Where portable beams for supporting wood hatch boards are made of steel, the maximum allowable stress and deflection under the design loads in 3-2-15/3.3 are as follows.

Maximum allowable stress	0.68Y
Maximum allowable deflection	0.0044 times the span

where  $Y$  is as defined in 3-2-15/7.1.1.

Where the cross section of portable beams is not constant along the span, Appendix 3-2-A6 may be used to determine required beam scantlings.

### 7.3.3 Closing/Securing Arrangements

Closing arrangements are to be in accordance with 3-2-15/7.1.2 through 3-2-15/7.1.6.

### 7.3.4 Carriers and Sockets

Carriers or sockets for portable beams are to be of substantial construction, and are to provide means for the efficient fitting and securing of the beams. Where rolling types of beams are used, the arrangements are to ensure that the beams remain properly in position when the hatchway is closed. The bearing surface is not to be less than 75 mm (3 in.) in width measured along the axis of the beam unless the carriers are of an interlocking type with the beam ends. Carriers for beams are to extend to the deck level or the coamings are to be fitted with stiffeners or external brackets in way of each beam.

## 7.5 Steel Hatch Covers

### 7.5.1 Scantlings (*1 January 2005*)

Where steel hatch covers are fitted on portable beams in place of wooden hatch boards, the maximum allowable stress and deflection under the design loads in 3-2-15/3.3 are as follows.

Maximum allowable stress	0.8Y, and not exceed the critical buckling strength in compression
Maximum allowable deflection	0.0056 times the span
Top plate thickness	0.01s, but not less than 6 mm (0.24 in.)

where  $Y$  is as defined in 3-2-15/7.1.1.

Covers are to be assumed to be simply supported.

Portable beams are to be in accordance with 3-2-15/7.3.2.

### 7.5.2 Closing Arrangements

Closing arrangements are to be in accordance with 3-2-15/7.1.2 through 3-2-15/7.1.6.

## 7.7 Bearing Surface

The width of each bearing surface for hatchway covers is to be at least 65 mm (2.5 in.).

## 7.9 Materials Other Than Steel

The strength and stiffness of covers made of materials other than steel are to be equivalent to those of steel and will be subject to special consideration.

# 9 Hatchways Closed by Covers of Steel Fitted with Gaskets and Clamping Devices

## 9.1 Strength of Covers (*1 January 2005*)

### 9.1.1 Scantlings

Where weathertight covers are steel, the maximum allowable stress and deflection under the design loads in 3-2-15/3.3 and the minimum top plate thickness are as follows.

Maximum allowable stress	$0.8Y$ , and not to exceed the critical buckling strength in compression
Maximum allowable deflection	0.0056 times the span
Top plate thickness	$0.01s$ , but not less than 6 mm (0.24 in.)

where  $Y$  and  $s$  are as defined in 3-2-15/7.1.1.

The following corrosion margin is to be incorporated into each strength member of the hatch cover:

- Single skin hatch covers, a corrosion addition  $t_s = 2.0$  mm (\*) for all plating and stiffeners.
- Double skin hatch covers, a corrosion addition  $t_s = 1.5$  mm (\*) for top and bottom plating and  $t_s = 1.0$  mm for the internal structure.

(\*) Corrosion addition  $t_s = 1.0$  mm for the hatch covers in way of cellular cargo holds intended for containers.

The value for cargo hatch covers for bulk carriers, ore carriers and combination carriers is given in 5-3-4/19.3.1(a).

Where the cross section of hatch cover stiffeners is not constant along the span, Appendix 3-2-A6 may be used to determine required scantlings.

## 9.3 Other Materials

The strength and stiffness of covers made of materials other than steel is to be equivalent to those of steel and is to be subject to special consideration.

## 9.5 Means for Securing Weathertightness (*1 January 2005*)

The means for securing and maintaining weathertightness are to be such that the tightness can be maintained in any sea conditions. The arrangements and the strength of these means of closing and securing of the covers to the anticipated sea loads are to comply with the requirements of 5-3-4/19.7. Where it is intended to carry cargoes on the covers, the securing means are also take into consideration these loads, including dynamic effects. Strength calculations for the means of securing hatch covers carrying cargoes are to be submitted for review. The covers are to be hose-tested in position under a water pressure of at least 2.1 bar (2.1 kgf/cm<sup>2</sup>, 30 psi) at the time of construction and, if considered necessary, at subsequent surveys.

## 9.7 Flush Hatch Covers

Where flush hatch covers are fitted on the freeboard deck, within the forward one-fourth length ( $L_f/4$ ), and the vessel is assigned a freeboard less than Type-B under the International Convention on Load Lines 1966, the assumed loads on flush hatch covers are to be increased 15% over that indicated in 3-2-15/9.1.

## 9.9 Container Loading (2002)

Where it is intended to carry containers on steel hatch covers, the exact locations of the container pads and the maximum total static load on the pads are to be indicated on the plans. Where the pads are not in line with supporting structures, headers are to be provided to transmit the loads to these members. Each member intended to support containers is to have a section modulus,  $SM$ , in  $\text{cm}^3$  ( $\text{in}^3$ ), not less than obtained from the following equation:

$$SM = M/f$$

where

$M$  = maximum bending moment due to maximum static container loading, in kN-cm (kgf-cm, Ltf-in)

$f$  = permissible maximum bending stress, not to exceed  $0.46Y$

$Y$  = specified yield point or yield strength, in  $\text{kN}/\text{cm}^2$  ( $\text{kgf}/\text{cm}^2$ ,  $\text{Ltf}/\text{in}^2$ ), as defined in 2-1-1/13, but is not to exceed 72% of the specified minimum tensile strength.

In determining the maximum bending moment, members are to be considered simply-supported.

The net sectional area of the web of the member, in  $\text{cm}^2$  ( $\text{in}^2$ ), including effective brackets where applicable, is to be not less than that obtained from the following equation:

$$A = F/q$$

where

$F$  = shearing force at the point under consideration, in kN (kgf, Ltf)

$q$  = permissible average shear stress in the web, not to exceed  $0.34Y$

The hatch cover is to be so designed as to limit the deflection to 0.0028 times the span under the static container load.

In addition, the dynamic forces associated with roll, pitch and heave motions of the vessel are to be considered for the design of the hatch cover. The dynamic forces due to ship motions are specified to be obtained from 5-3-3/5.7.1 for bulk carriers over 150 meters (492 ft) in length, from 5-5-3/5.5.1 for container carriers over 130 meters (427 ft) in length and from Section 4.3 of *ABS Guide for Certification of Container Securing Systems* for all other vessels. Where predicted by ship motion calculations, the statistically appropriate effects of roll, pitch and heave may be used. The following permissible stresses may be used for those dynamic loading conditions:

$f$  = permissible maximum bending stress, not to exceed  $0.80Y$

$q$  = permissible average shear stress in the web, not to exceed  $0.53Y$

Where higher strength steels are used, calculations are to be submitted to show adequate provision against buckling.

## 11 Hatchways in Decks at Higher Levels

### 11.1 Gasketless Covers

Special consideration will be given to the omission of gaskets on covers on hatchways in decks located above Position 2 where it can be shown that the closing arrangements are weathertight. The procedure for testing such covers will also be subject to special consideration. For tests during subsequent surveys, see 7-3-2/1.1.1(f) and 7-3-2/5.1.10.

## 13 Hatchways in Lower Decks or within Fully Enclosed Superstructures

### 13.1 General

The following scantlings are intended for ocean-going vessels and conventional type covers. Those scantlings for covers of special types or for vessels of restricted service are to be specially considered.

### 13.3 Beams and Wood Covers (1997)

Hatchways in lower decks or within fully enclosed superstructures are to be framed with beams of sufficient strength. Where such hatches are intended to carry a load of cargo, the hatch beams are to have a section modulus  $SM$  not less than that obtained from the following equation:

$$SM = 7.8chs\ell^2 \text{ cm}^3$$

$$SM = 0.0041chs\ell^2 \text{ in}^3$$

where

$$c = 1.18$$

$$h = \text{tween-deck height, in m (ft). When a design load is specified, } h \text{ is to be taken as } p/n \text{ where } p \text{ is the specified design pressure, in kN/m}^2 \text{ (kgf/m}^2, \text{ lbf/ft}^2\text{), and } n \text{ is defined as 7.04 (715, 45).}$$

$$s = \text{spacing of hatch beams, in m (ft)}$$

$$\ell = \text{length of hatch beams, in m (ft)}$$

The wood covers are not to be less than 63.5 mm (2.50 in.) thick where the spacing of the beams does not exceed 1.52 m (5 ft). Where the height to which the cargo may be loaded on top of a hatch exceeds about 2.6 m (8.5 ft), or where the spacing of the beams exceeds 1.52 m (5 ft), the thickness of the wood covers is to be suitably increased.

### 13.5 Steel Covers

Where steel covers are fitted, the thickness of the plating is to be not less than required for platform decks in enclosed cargo spaces as obtained from 3-2-3/5.1. A stiffening bar is to be fitted around the edges, as required, to provide the necessary rigidity to permit the covers being handled without deformation. The effective depth of the framework is normally to be not less than 4% of its unsupported length. Each stiffener in association with the plating to which it is attached is to have section modulus  $SM$  not less than that obtained from the following equation:

$$SM = 7.8hs\ell^2 \text{ cm}^3$$

$$SM = 0.0041hs\ell^2 \text{ in}^3$$



where

- $h$  = tween-deck height, in m (ft). When a design load is specified,  $h$  is to be taken as  $p/n$  where  $p$  is the specified design pressure, in kN/m<sup>2</sup> (kgf/m<sup>2</sup>, lbf/ft<sup>2</sup>), and  $n$  is defined as 7.04 (715, 45).
- $s$  = spacing of the stiffeners, in m (ft)
- $\ell$  = length of the stiffener, in m (ft)

### 13.7 Wheel Loading

Where provision is to be made for the operation or stowage of vehicles having rubber tires, the thickness of the hatch cover plating is to be not less than obtained from 3-2-3/5.17, for platform deck plating, except that the thickness of plate panels adjacent to the edges of the covers is to be at least 15% greater than obtained from 3-2-3/5.17.

## 14 Small Hatches on the Exposed Fore Deck (2004)

### 14.1 Application

The requirements of this subsection apply to all small hatches [opening normally 2.5 m<sup>2</sup> (27 ft<sup>2</sup>) or less] located on the exposed fore deck within the forward 0.25 $L$ , where the deck in way of the hatch is less than 0.1 $L$  or 22 m (72.2 ft) above the summer load line, whichever is less.

Hatches designed for emergency escape need not comply with 3-2-15/14.5i), 3-2-15/14.5ii), the third paragraph of 3-2-15/14.7 and 3-2-15/14.9.

### 14.3 Strength

For small rectangular steel hatch covers, the plate thickness, stiffener arrangement and scantlings are to be in accordance with 3-2-15/Table 1 and 3-2-15/Figure 1. Stiffeners, where fitted, are to be aligned with the metal-to-metal contact points required in 3-2-15/14.7 (see also 3-2-15/Figure 1). Primary stiffeners are to be continuous. All stiffeners are to be welded to the inner edge stiffener (see 3-2-15/Figure 2).

The upper edge of the hatchway coaming is to be suitably reinforced by a horizontal section, normally not more than 170 to 190 mm (6.9 to 7.5 in.) from the upper edge of the coaming.

For small hatch covers of circular or similar shape, the cover plate thickness and reinforcement is to provide strength and stiffness equivalent to the requirements for small rectangular hatches.

For small hatch covers constructed of materials other than steel, the required scantlings are to provide strength and stiffness equivalent to 235 N/mm<sup>2</sup> (24 kgf/mm<sup>2</sup>, 34,000 psi) yield strength steel.

### 14.5 Primary Securing Devices

The primary securing devices are to be such that their hatch covers can be secured in place and made weathertight by means of a mechanism employing any one of the following methods:

- i) Butterfly nuts tightening onto forks (clamps), or
- ii) Quick acting cleats, or
- iii) A central locking device.

Dogs (twist tightening handles) with wedges are not acceptable.

### 14.7 Requirements for Primary Securing

The hatch cover is to be fitted with a gasket of elastic material. This is to be designed to allow a metal-to-metal contact at a designed compression and to prevent over compression of the gasket by green sea forces that may cause the securing devices to be loosened or dislodged. The metal-to-metal contacts are to be arranged close to each securing device, in accordance with 3-2-15/Figure 1, and of sufficient capacity to withstand the bearing force.

The primary securing method is to be designed and manufactured such that the designed compression pressure is achieved by one person without the need of any tools.

For a primary securing method using butterfly nuts, the forks (clamps) are to be of robust design. They are to be designed to minimize the risk of butterfly nuts being dislodged while in use, by means of curving the forks upward and a raised surface on the free end, or a similar method. The plate thickness of unstiffened steel forks is not to be less than 16 mm ( $5/8$  in.). An example arrangement is shown in 3-2-15/Figure 2.

For small hatch covers located on the exposed deck forward of the fore-most cargo hatch, the hinges are to be fitted such that the predominant direction of green sea will cause the cover to close, which means that the hinges are normally to be located on the fore edge.

On small hatches located between the main hatches, for example, between Nos. 1 and 2, the hinges are to be placed on the fore edge or outboard edge, whichever is practicable for protection from green water in beam sea and bow quartering conditions.

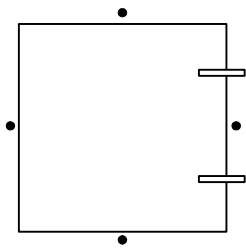
### 14.9 Secondary Devices

Small hatches on the fore deck are to be fitted with an independent secondary securing device, e.g., by means of a sliding bolt, a hasp or a backing bar of slack fit, which is capable of keeping the hatch cover in place even in the event that the primary securing device became loosened or dislodged. It is to be fitted on the side opposite to the hatch cover hinges.

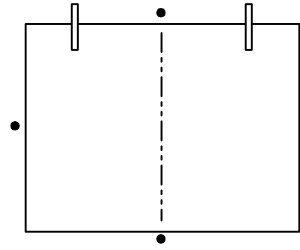
**TABLE 1**  
**Scantlings for Small Steel Hatch Covers on the Fore Deck**

Nominal Size (mm × mm)	Cover Plate Thickness (mm)	Primary Stiffeners	Secondary Stiffeners
		Flat Bar (mm × mm); number	
630 × 630	8	---	---
630 × 830	8	100 × 8; 1	---
830 × 630	8	100 × 8; 1	---
830 × 830	8	100 × 10; 1	---
1030 × 1030	8	120 × 12; 1	80 × 8; 2
1330 × 1330	8	150 × 12; 2	100 × 10; 2

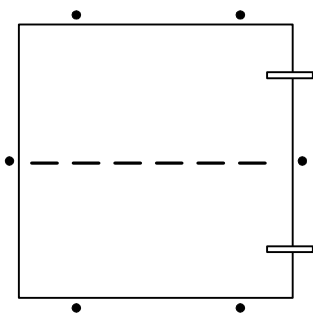
**FIGURE 1**  
**Arrangement of Stiffeners**



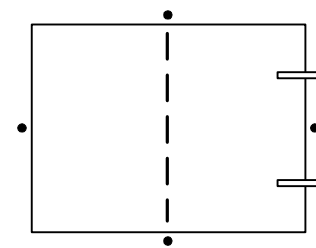
Nominal size 630 × 630



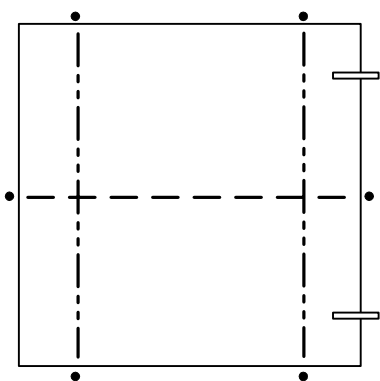
Nominal size 630 × 830



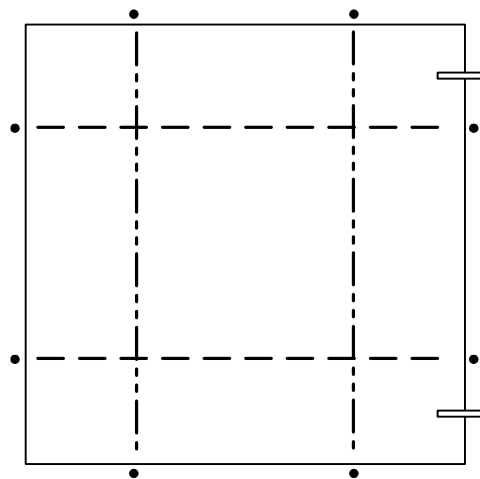
Nominal size 830 × 830



Nominal size 830 × 630



Nominal size 1030 × 1030



Nominal size 1330 × 1330

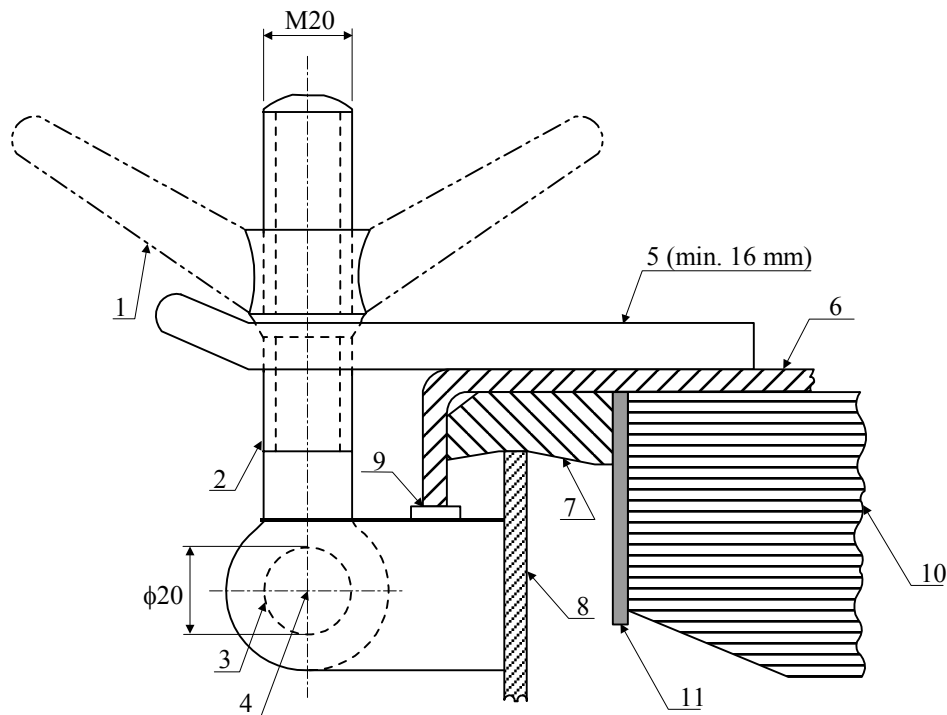
≡ Hinge

• Securing device/metal to metal contact

— — — Primary stiffener

· · · Secondary stiffener

**FIGURE 2**  
**Example of Primary Securing Method**



- 1: butterfly nut  
 2: bolt  
 3: pin  
 4: center of pin  
 5: fork (clamp) plate  
 6: hatch cover  
 7: gasket  
 8: hatch coaming  
 9: bearing pad welded on the bracket of a toggle bolt for metal to metal contact  
 10: stiffener  
 11: inner edge stiffener
- (Note: Dimensions in millimeters)

## 15 Other Hatchways

### 15.1 Hatchways within Open Superstructures

Hatchways within open superstructures are to be considered as exposed.

### 15.3 Hatchways within Deckhouses

Hatchways within deckhouses are to have coamings and closing arrangements as required in relation to the protection afforded by the deckhouse from the standpoint of its construction and the means provided for the closing of all openings into the house.

## 17 Additional Requirements for Subdivision

### 17.1 External Opening below Damage Waterline

All external openings leading to compartments assumed intact in the damage analysis, which are permitted by 3-3-1/3.3 to be below the final damage waterline, are to be watertight. Except for hatch covers, these openings are to be fitted with indicators on the bridge showing whether the closing appliances are open or closed.

### 17.3 Internal Openings

The openings and penetrations in internal decks required to be watertight for subdivision are to meet the corresponding requirements for watertight doors in 3-2-9/1.3 and 3-2-9/9.

## 19 Machinery Casings

### 19.1 Arrangement (2002)

Machinery-space openings in Position 1 or 2 are to be framed and efficiently enclosed by steel casings of ample strength, and, wherever practicable, those in freeboard decks are to be within superstructures or deckhouses. Where the machinery casings are exposed, plating and stiffeners are to be in accordance with the requirements in 3-2-11/3. Access openings in exposed casings are to be fitted with doors complying with the requirements of 3-2-11/5.3, the sills of which are to be at least 600 mm (23.5 in.) above the deck if in Position 1, and at least 380 mm (15 in.) above the deck if in Position 2. Where the vessel is assigned a freeboard less than that based on Table B as allowed by the International Convention on Load Lines, 1966, there are generally to be no openings giving direct access from the freeboard deck to the machinery space. A door, complying with the requirements of 3-2-11/5.3, may however be permitted in the exposed machinery casing, provided that it leads to a space or passageway that is as strongly constructed as the casing and is separated from the engine room by a second door complying with 3-2-11/5.3. The sill of the exterior door is not to be less than 600 mm (23.5 in.), and the sill of the second/interior door is to be not less than 230 mm (9 in.). Other openings in such casings are to be fitted with equivalent covers, permanently attached in their proper positions. See also 4-7-2/1.11.5 and 4-7-2/1.11.6.

### 19.3 Fiddleys, Funnels, and Ventilators

Coamings of any fiddley, funnel or machinery-space ventilator in an exposed position on the freeboard or superstructure deck are to be as high above the deck as is reasonable and practicable. Fiddley openings are to be fitted with strong covers of steel or other equivalent material, permanently attached in their proper positions and capable of being secured weathertight.

### 19.5 Casings within Open Superstructures (2002)

Casings within open superstructures are to be of similar scantlings to those obtained from 3-2-11/3 for exposed casings on superstructure decks. Where there are no end bulkheads to the superstructures, the arrangements and scantlings are to be in compliance with 3-2-11/3 for an exposed casing on the freeboard deck.

### 19.7 Casings within Enclosed Superstructures (2002)

The thickness of casings within enclosed superstructures is to be not less than obtained from the following equation:

$$t = 4.6 + L/64 + (s - 760)/150 \quad \text{mm} \quad \text{but not less than 6.0 mm}$$

$$t = 0.146 + L/3500 + (s - 30)/150 \quad \text{in.} \quad \text{but not less than 0.23 in.}$$

The thickness of casing sides in accommodation spaces above the crown of the machinery space is not to be less than obtained from the following equation:

$$t = 4.5 + (s - 760)/150 \quad \text{mm}$$

$$t = 0.18 + (s - 30)/150 \quad \text{in.}$$

where

$L$  = length of vessel, as defined in 3-1-1/3.1, in m (ft) but need not be taken greater than 122 m (400 ft)

$s$  = the stiffener spacing, in mm (in.), but is not to be taken less than 760 mm (30 in.)

Where accelerated corrosion is expected, such as in way of wet spaces, the thickness of coaming plates may need to be increased. Where casings are used in lieu of girders or deep beams, the plating in way is to be suitably increased. Stiffeners are to be fitted in line with the beams and are to have a section modulus  $SM$  not less than obtained from the following equation:

$$SM = 7.8chs\ell^2 \quad \text{cm}^3$$

$$SM = 0.0041chs\ell^2 \quad \text{in}^3$$

where

$c$  = 0.14

$s$  = spacing of stiffeners, in m (ft)

$h$  = tween-deck height, in m (ft)

$\ell$  = length, between support, of the stiffeners, in m (ft)

Casings which support girders or pillars are to be suitably stiffened in such manner as to provide supports not less effective than required for stanchions or pillars.

## 19.9 Casings within Deckhouses

Casings within deckhouses are to have scantlings, sill heights and closing arrangements to entrances as required in relation to the protection offered by the deckhouse from the standpoint of its construction and the means for closing all openings into the house.

## 21 Miscellaneous Openings in Freeboard and Superstructure Decks

### 21.1 Manholes and Scuttles

Manholes and flush scuttles in Position 1 or 2 or within superstructures other than enclosed superstructures are to be closed by substantial covers capable of being made watertight. Unless secured by closely spaced bolts, the covers are to be permanently attached.

### 21.3 Other Openings

Openings in freeboard decks other than hatchways, machinery-space openings, manholes and flush scuttles are to be protected by an enclosed superstructure, or by a deckhouse or companionway of equivalent strength and weathertightness. Any such opening in an exposed superstructure deck or in the top of a deckhouse on the freeboard deck which gives access to a space below the freeboard deck or a space within an enclosed superstructure is to be protected by an efficient deckhouse or companionway. Doorways in such deckhouses or companionways are to be fitted with doors complying with the requirements of 3-2-11/5.3.

### 21.5 Escape Openings

The closing appliances of escape openings are to be readily operable from each side.

### 21.7 Companionway Sills

In Position 1, the height above the deck of sills to the doorways in companionways is to be at least 600 mm (23.5 in.). In Position 2, they are to be at least 380 mm (15 in.).

### 21.9 Mast Openings

Openings penetrating decks and other structures to accommodate masts, kingposts and similar members are to be reinforced by fitting doublings or plating of increased thickness.

### 21.11 Chain Pipe Opening (1 July 2003)

Chain pipes through which anchor cables are led are to be provided with permanently attached closing appliances to minimize the ingress of water. A canvas cover with appropriate lashing arrangement will be acceptable for this purpose. A cement and wire mesh arrangement is not permitted.

The arrangement on vessels that are not subject to the International Convention on Load Lines or its Protocol may be specially considered.

This Page Intentionally Left Blank



PART

# 3

CHAPTER **2 Hull Structures and Arrangements**

APPENDIX **6 Portable Beams and Hatch Cover Stiffeners of Variable Cross Section (1997)**

## 1 Application

For portable beams and hatch cover stiffeners with free ends and varying cross section along their span, the section modulus  $SM$  and inertia  $I$  at the midspan required by 3-2-15/7.1.1, 3-2-15/7.3.2, 3-2-15/7.5.1 and 3-2-15/9.1 may be obtained from the following equations.

$$SM = \frac{C_1 K_1 p s \ell^2}{\sigma_a} \quad \text{cm}^3 \text{ (in}^3\text{)}$$

$$I = C_2 K_2 p s \ell^3 \quad \text{cm}^4 \text{ (in}^4\text{)}$$

where

$$C_1 = 125 \text{ (125, 1.5)}$$

$$C_2 = 2.87 \text{ (28.2, } 2.85 \times 10^{-5}\text{) for 3-2-15/7.1.1 and 3-2-15/7.3.2}$$

$$= 2.26 \text{ (22.1, } 2.24 \times 10^{-5}\text{) for 3-2-15/7.5.1 and 3-2-15/9.1}$$

$$K_1 = 1 + \frac{3.2\alpha - \gamma - 0.8}{7\gamma + 0.4}, \text{ but not less than 1.0}$$

$$\alpha = \text{length ratio}$$

$$= \ell_1 / \ell$$

$$\gamma = SM \text{ ratio}$$

$$= SM_1 / SM$$

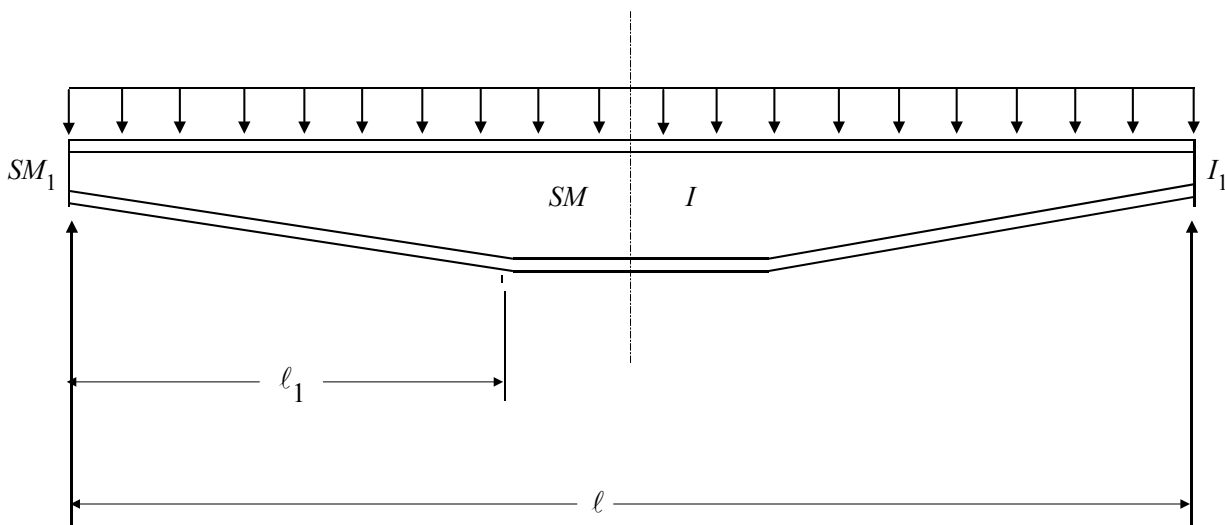
$\ell_1$ ,  $\ell$ ,  $SM_1$  and  $SM$  are as indicated in 3-2-A6/Figure 1.

$$\sigma_a = \text{allowable stress given in 3-2-15/7.1.1, 3-2-15/7.3.2, 3-2-15/7.5.1 and 3-2-15/9.1, in kN/mm}^2 \text{ (kgf/mm}^2\text{, psi)}$$

$$K_2 = 1 + 8\alpha^3 \frac{(1-\beta)}{(0.2+3\sqrt{\beta})}, \text{ but not less than 1.0}$$

- $\beta$  = ratio of the moments of inertia,  $I_1$  and  $I$ , at the locations indicated in 3-2-A6/Figure 1  
=  $I_1/I$
- $p$  = design load given in 3-2-15/3.3, in  $\text{kN/m}^2$  (tf/m<sup>2</sup>, psi)
- $s$  = spacing of beams or stiffeners, in m (ft).
- $\ell$  = span of free ended constructional elements, in m (ft).

**FIGURE 1**  
***SM* and *I* of Construction Elements**



PART

**3**

CHAPTER **2 Hull Structures and Arrangements**

SECTION **16 Protection of Shell Openings**

**1 Cargo, Gangway, or Fueling Ports**

**1.1 Construction (1997)**

Cargo, gangway, or fueling ports in the sides of vessels are to be strongly constructed and capable of being made thoroughly watertight. Where frames are cut in way of such ports, web frames are to be fitted on each side of the opening and suitable arrangements are to be provided for the support of the beams over the opening. Shell doublings are to be fitted, as required, to compensate for the openings, and the corners of the openings are to be well rounded. Waterway angles and scuppers are to be provided on the deck in way of openings in cargo spaces below the freeboard deck or in cargo spaces within enclosed superstructures to prevent the spread of any leakage water over the deck.

Indicators showing whether the ports in the side shell below the freeboard or superstructure deck are secured closed or open are to be provided on the navigation bridge.

Where allowed by 3-2-16/1.3, cargo ports or similar openings located with their lower edge below the line defined in 3-2-16/1.3 are to be fitted with a second door of equivalent strength and watertightness with a leakage detection device for the compartment between the doors. The drain from this compartment is to be led to the bilge with a screwdown valve operable from an accessible location.

In general, all outer doors are to open outwards.

**1.3 Location (1997)**

Unless especially approved, the lower edge of cargo, gangway, or fueling port openings is not to be below a line drawn parallel to the freeboard deck at side, which has at its lowest point the upper edge of the uppermost load line.

Cargo ports or similar openings may be located with their lower edge below the above defined line, provided they meet the additional construction requirements of 3-2-16/1.1.

**1.5 Subdivision Requirements**

Openings in the shell plating below the deck, limiting the vertical extent of damage, are to be kept permanently closed while at sea. Should any of these openings be accessible during the voyage, their closing appliances are to be fitted with a device which prevents unauthorized opening.

Closing appliances which are kept permanently closed at sea to ensure the watertight integrity of external openings but are not fitted with a device which prevents unauthorized opening, due to their inaccessibility during the voyage, are to be provided with a notice affixed to each such closing appliance to the effect that it is to be kept closed.

### **3 Bow Doors, Inner Doors, Side Shell Doors and Stern Doors (1998)**

#### **3.1 General (2005)**

Where bow doors of the visor or side-opening type are fitted leading to complete or long forward enclosed superstructures, or to long superstructures with closing appliances to the satisfaction of the Administration, bow doors and inner doors are to meet the requirements of this section. Hull supporting structure in way of the bow doors is to be able to withstand the loads imposed by the bow door securing and supporting devices without exceeding the allowable stresses for those devices, both given in this section.

Side shell doors fitted abaft of the collision bulkhead and stern doors leading into enclosed spaces are to meet the requirements of this section.

#### **3.3 Arrangement**

##### **3.3.1 General**

As far as practicable, bow doors and inner doors are to be arranged so as to preclude the possibility of the bow door causing structural damage to the inner door or to the collision bulkhead in the case of damage to or detachment of the bow door.

##### **3.3.2 Bow Doors**

Bow doors are to be situated above the freeboard deck, except that where a watertight recess fitted for arrangement of ramps or other related mechanical devices is located forward of the collision bulkhead and above the deepest waterline, the bow doors may be situated above the recess.

##### **3.3.3 Inner Doors**

An inner door is to be fitted in the extension of the collision bulkhead required by 3-2-9/3.1.1. A vehicle ramp made watertight and conforming to 3-2-9/Figure 1 in the closed position may be accepted for this purpose.

##### **3.3.4 Side Shell and Stern Doors (1998)**

Stern doors for passenger vessels are to be situated above the freeboard deck. Stern doors for ro-ro cargo vessels and all side shell doors need not be situated above the freeboard deck.

### **5 Securing, Locking and Supporting of Doors**

#### **5.1 Definitions**

##### **5.1.1 Securing Device**

A device used to keep the door closed by preventing it from rotating about its hinges or its pivoted attachments to the vessel.

##### **5.1.2 Supporting Device**

A device used to transmit external or internal loads from the door to a securing device and from the securing device to the vessel's structure, or a device other than a securing device, such as a hinge, stopper or other fixed device, that transmits loads from the door to the vessel's structure.

### 5.1.3 Locking Device

A device that locks a securing device in the closed position.

## 7 Securing and Supporting Devices (1998)

### 7.1 General

Securing and supporting devices are to be arranged in accordance with this subsection, and are to have scantlings as required by 3-2-16/13.9, 3-2-16/15.5 or 3-2-16/17.9, as appropriate.

### 7.3 Bow Doors

Means are to be provided to prevent lateral or vertical movement of the bow doors when closed. Means are also to be provided for mechanically fixing the door in the open position.

Means of securing and supporting the door are to maintain equivalent strength and stiffness of the adjacent structure.

#### 7.3.1 Clearance and Packing

The maximum design clearance between the door and securing/supporting devices is not to exceed 3 mm (0.12 in.). Where packing is fitted, it is to be of a comparatively soft type and the supporting forces are to be carried by the steel structure only.

#### 7.3.2 Visor Door Arrangement

The pivot arrangement is to be such that the visor is self-closing under external loads. The closing moment,  $M_y$ , as defined in 3-2-16/19.5.1, is not to be less than  $M_{yo}$ , as given by the following equation:

$$M_{yo} = Wc + 0.1 \sqrt{a^2 + b^2} \sqrt{F_x^2 + F_z^2}$$

where  $W$ ,  $a$ ,  $b$ ,  $c$ ,  $F_x$  and  $F_z$  are as defined in 3-2-16/17.

In addition, the arrangement of the door is to be such that the reaction forces of pin or wedge supports at the base of the door does not act in the forward direction when the door is loaded in accordance with 3-2-16/19.5.4.

### 7.5 Side Shell and Stern Doors (1998)

Means are to be provided to prevent lateral or vertical movement of the side shell or stern doors when closed. Means are also to be provided for mechanically fixing the doors in the open position.

The means of securing and supporting the doors are to have strength and stiffness equivalent to the adjacent structure.

Clearance and packing for side shell and stern doors are to be in accordance with 3-2-16/7.3.1.

## 9 Securing and Locking Arrangement

### 9.1 General

Securing devices are to be provided with a mechanical locking arrangement (self locking or separate arrangement), or are to be of the gravity type.

### 9.3 Operation

Securing devices are to be simple to operate and readily accessible. The opening and closing systems as well as the securing and locking devices are to be interlocked in such a way that they can only operate in the proper sequence.

## 11 Tightness

### 11.1 Bow Doors

Bow doors are to be so fitted as to ensure tightness consistent with operational conditions and to give effective protection to the inner doors.

### 11.3 Inner Doors

Inner doors forming part of the extension of the collision bulkhead are to be weathertight over the full height of the cargo space and arranged with fixed sealing supports on the aft side of the doors.

### 11.5 Side Shell and Stern Doors (1998)

Side shell doors and stern doors are to be so fitted as to ensure water tightness.

## 13 Bow Door Scantlings

### 13.1 General

Bow doors are to be framed and stiffened so that the whole structure is equivalent to the intact bow structure when closed.

### 13.3 Primary Structure (2005)

Scantlings of primary members are to be designed so that the allowable stresses indicated in 3-2-16/25.1 are not exceeded when the structure is subjected to the design loads indicated in 3-2-16/19.1. Normally, simple beam theory may be applied to determine the bending stresses. Members are to be considered to have simply supported end connections.

### 13.5 Secondary Stiffeners

Secondary stiffeners are to be supported by primary members constituting the main stiffening of the door. The section modulus,  $SM$ , of secondary stiffeners is to be as required in 3-2-5/1.1 and 3-2-5/5. Consideration is to be given, where necessary, to differences in fixity between the requirements in 3-2-5/1.1, 3-2-5/5, and bow door stiffeners.

In addition, stiffener webs are to have a net sectional area not less than that obtained from the following equation:

$$A = VQ/10 \text{ cm}^2 \quad (A = VQ \text{ cm}^2, A = VQ/6.5 \text{ in}^2)$$

where

$V$  = shear force, in kN (tf, Ltf), in the stiffener calculated using the uniformly distributed external pressure,  $P_{eb}$ , given in 3-2-16/19.1

$Q$  = as defined in 3-2-1/5.5

## 13.7 Plating

The thickness of bow door plating is to be not less than that required for side shell plating at the same location.

## 13.9 Securing and Supporting Devices (2005)

Scantlings of securing and supporting devices are to be designed so that the allowable stresses indicated in 3-2-16/25.1 are not exceeded when the structure is subjected to the design loads indicated in 3-2-16/19.3. All load-transmitting elements in the design load path from the door through securing and supporting devices into the vessel structure, including welded connections, are to meet the strength standards required for securing and supporting devices. These elements include pins, support brackets and back-up brackets. Where fitted, threaded bolts are not to carry support forces, and the maximum tensile stress in way of the threads is not to exceed the allowable stress given in 3-2-16/25.5.

In determining the required scantlings, the door is to be assumed to be a rigid body. Only those active supporting and securing devices having an effective stiffness in the relevant direction are to be included and considered when calculating the reaction forces on the devices. Small or flexible devices such as cleats intended to provide compression load on the packing material are not to be included in the calculations.

### 13.9.1 Bearing Pressure

The bearing pressure on steel to steel bearings is to be calculated by dividing the design force by the projected bearing area, and is not to exceed the allowable stress given in 3-2-16/25.3.

### 13.9.2 Redundancy

In addition to the above requirements, the arrangement of the securing and supporting devices is to be designed with redundancy such that in the event of failure of any single securing or supporting device, the stresses in the remaining devices do not exceed the allowable stresses indicated in 3-2-16/25.1 by more than 20% under the above loads.

### 13.9.3 Visor Door Securing and Supporting Devices

Securing and supporting devices, excluding the hinges, are to be capable of resisting the vertical design force given in 3-2-16/19.5.3 without exceeding the allowable stresses in 3-2-16/25.1.

Two securing devices are to be provided at the lower part of the door, each capable of providing the full reaction force required to prevent opening of the door without stresses exceeding the allowable stresses indicated in 3-2-16/25.1. The opening moment,  $M_o$ , to be balanced by this force is as given in 3-2-16/19.5.2.

### 13.9.4 Side-opening Door Thrust Bearing

A thrust bearing is to be provided in way of girder ends at the closing of the two doors, and is to prevent one door from shifting towards the other one under the effect of unsymmetrical pressure. Securing devices are to be fitted to secure sections thrust bearing to one another.

## 13.11 Visor Door Lifting Arms and Supports

Where visor type bow doors are fitted, calculations are to be submitted verifying that lifting arms and their connections to the door and vessel structure are adequate to withstand the static and dynamic forces applied during the lifting and lowering operations under a wind pressure of at least 1.5 kN/m<sup>2</sup> (0.15 tf/m<sup>2</sup>, 0.014 Ltf/ft<sup>2</sup>).

## 15 Inner Door Scantlings

### 15.1 General

Scantlings of inner doors are to meet the requirements of this subsection. In addition, where inner doors are used as vehicle ramps, scantlings are not to be less than required for vehicle decks in Section 3-2-3, Section 3-2-7 and Section 3-2-8.

### 15.3 Primary Structure

Scantlings of primary members are to be designed so that the allowable stresses indicated in 3-2-16/25.1 are not exceeded when the structure is subjected to the design loads indicated in 3-2-16/21.1.

### 15.5 Securing and Supporting Devices

Scantlings of securing and supporting devices are to be designed so that the allowable stresses indicated in 3-2-16/25.1 are not exceeded when the structure is subjected to the design loads indicated in 3-2-16/21. Where fitted, threaded bolts are not to carry support forces, and the maximum tensile stress in way of the threads is not to exceed the allowable stress given in 3-2-16/25.5.

The bearing pressure on steel to steel bearings is to be calculated by dividing the design force by the projected bearing area, and is not to exceed the allowable stress given in 3-2-16/25.3.

## 17 Side Shell Door and Stern Door Scantlings (1998)

### 17.1 General

Scantlings of side shell doors or stern doors are to meet the requirements of this subsection. In addition, where the doors are used as vehicle ramps, scantlings are not to be less than required for vehicle decks in Section 3-2-3, Section 3-2-7 and Section 3-2-8.

### 17.3 Primary Structure (2005)

Scantlings of primary members are to be designed so that the allowable stresses indicated in 3-2-16/25.1 are not exceeded when the structure is subjected to the design loads indicated in 3-2-16/23. Normally, simple beam theory may be applied to determine the bending stresses. Members are considered to have simply supported end connections.

### 17.5 Secondary Stiffeners

Secondary stiffeners are to be supported by primary members constituting the main stiffening of the door. The section modulus,  $SM$ , of secondary stiffeners is to be not less than required by Section 3-2-5 for frames in the same location. In addition, the net sectional area of stiffener webs is to be in accordance with 3-2-16/13.5, using the external pressure,  $p_e$ , given in 3-2-16/23.

### 17.7 Plating

The thickness of side or stern door plating is to be not less than that required for side shell plating at the same location.



## 17.9 Securing and Supporting Devices

Scantlings of securing and supporting devices are to be designed so that the allowable stresses indicated in 3-2-16/25.1 are not exceeded when the structure is subjected to the design loads indicated in 3-2-16/23. All load-transmitting elements in the design load path from the door through securing and supporting devices into the vessel structure, including welded connections, are to meet the strength standards required for securing and supporting devices. Where fitted, threaded bolts are not to carry support forces, and the maximum tensile stress in way of the threads is not to exceed the allowable stress given in 3-2-16/25.5.

In determining the required scantlings, the door is to be assumed to be a rigid body. Only those active supporting and securing devices having an effective stiffness in the relevant direction are to be included and considered when calculating the reaction forces on the devices. Small or flexible devices such as cleats intended to provide compression load on the packing material are not to be included in the calculations.

### 17.9.1 Bearing Pressure

The bearing pressure on steel-to-steel bearings is to be calculated by dividing the design force by the projected bearing area, and is not to exceed the allowable stress given in 3-2-16/25.3.

### 17.9.2 Redundancy

In addition to the above requirements, the arrangement of the securing and supporting devices is to be designed with redundancy such that in the event of a failure of any single securing or supporting device, the stresses in the remaining devices do not exceed the allowable stresses indicated in 3-2-16/25.1 by more than 20% under the above loads.

## 19 Bow Door Design Loads

### 19.1 External Pressure

The design external pressure,  $P_{eb}$ , is to be taken as indicated by the following equation:

$$P_{eb} = nc (0.22 + 0.15 \tan \beta) (0.4V_d \sin \alpha + 0.6\sqrt{kL_1})^2 \text{ kN/m}^2 \text{ (tf/m}^2, \text{ Ltf/ft}^2)$$

where

$$n = 2.75 (0.280, 0.0256)$$

$$c = 1.0$$

$$L = \text{length of vessel, as defined in 3-1-1/3.1, in m (ft).}$$

$$L_1 = \text{length of vessel, in m (ft), as defined in 3-1-1/3.1, but need not be taken as greater than 200 m (656 ft).}$$

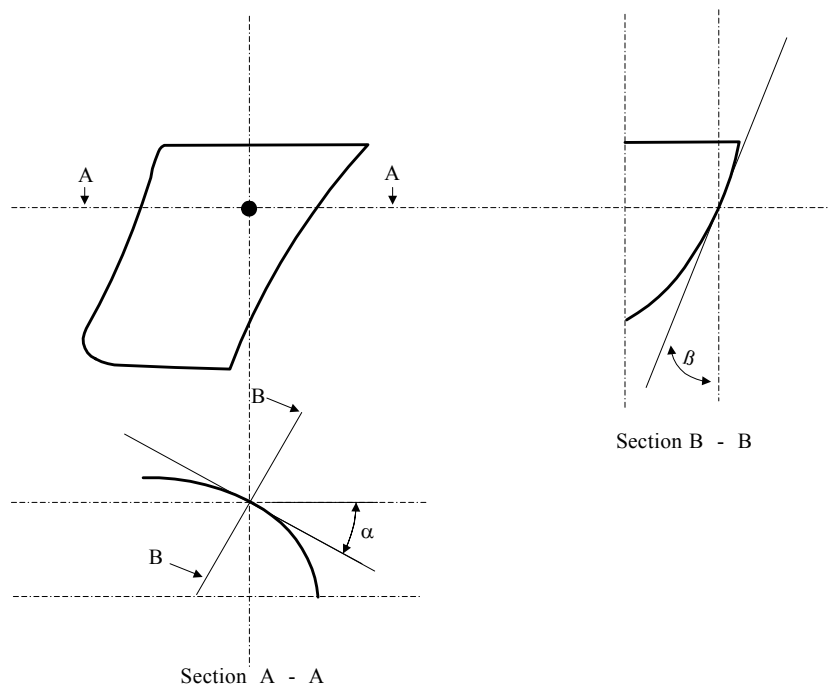
$$\beta = \text{flare angle at the point to be considered, defined as the angle between a vertical line and the tangent to the side shell plating measured in a vertical plane normal to the horizontal tangent to the shell plating. See 3-2-16/Figure 1.}$$

$$\alpha = \text{entry angle at the point to be considered, defined as the angle between a longitudinal line parallel to the centerline and the tangent to the shell plating in a horizontal plane. See 3-2-16/Figure 1.}$$

$$k = 1.0 (1.0, 0.305)$$

$$V_d = \text{vessel design speed, as defined in 3-2-14/3.1.}$$

**FIGURE 1**  
**Entry and Flare Angles**



### 19.3 External Forces (2005)

The design external forces considered in determining scantlings of securing and supporting devices of bow doors are not to be taken less than those given by the following equations:

$$F_x = P_{em} A_x$$

$$F_y = P_{em} A_y$$

$$F_z = P_{em} A_z$$

where

$F_x$  = the design external force in the longitudinal direction, in kN (tf, Ltf)

$F_y$  = the design external force in the horizontal direction, in kN (tf, Ltf)

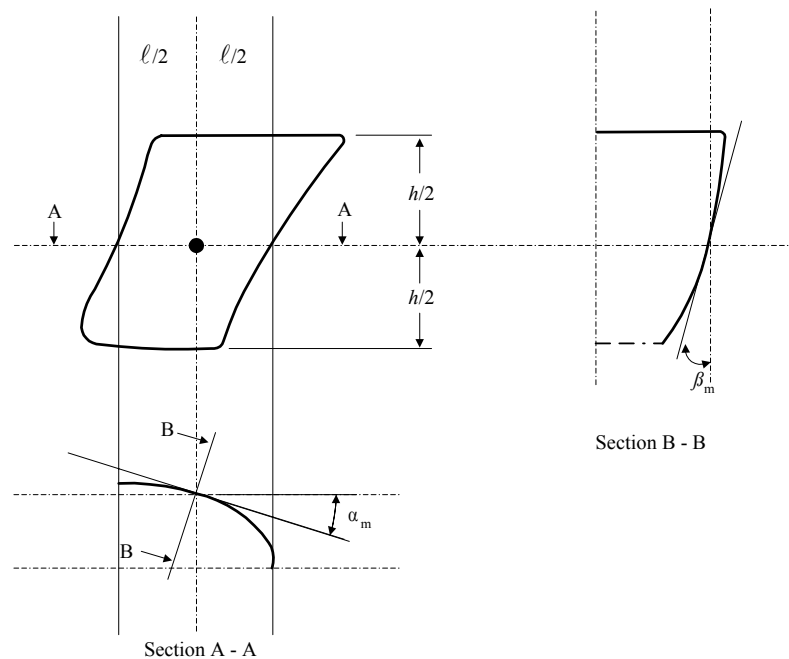
$F_z$  = the design external force in the vertical direction, in kN (tf, Ltf)

$A_x$  = area, in m<sup>2</sup> (ft<sup>2</sup>), of the transverse projection of the door between the levels of the bottom of the door and the top of the upper deck bulwark or between the bottom of the door and the top of the door, whichever is the lesser. Where the flare angle of the bulwark is at least 15° less than the flare of the adjacent shell plating, the bulwark may be excluded and the distance may be measured from the bottom of the door to the upper deck or to the top of the door, whichever is the lesser.

$A_y$  = area, in m<sup>2</sup> (ft<sup>2</sup>), of the longitudinal projection of the door between the levels of the bottom of the door and the top of the upper deck bulwark or between the bottom of the door and the top of the door, whichever is the lesser. Where the flare angle of the bulwark is at least 15° less than the flare of the adjacent shell plating, the bulwark may be excluded and the distance may be measured from the bottom of the door to the upper deck or to the top of the door, whichever is the lesser.

- $A_z$  = area, in  $m^2$  ( $ft^2$ ), of the horizontal projection of the door between the levels of the bottom of the door and the top of the upper deck bulwark or between the bottom of the door and the top of the door, whichever is the lesser. Where the flare angle of the bulwark is at least  $15^\circ$  less than the flare of the adjacent shell plating, the bulwark may be excluded and the distance may be measured from the bottom of the door to the upper deck or to the top of the door, whichever is the lesser.
- $P_{em}$  = bow door pressure,  $P_{eb}$ , determined using  $\alpha_m$  and  $\beta_m$  in place of  $\alpha$  and  $\beta$ .
- $\beta_m$  = flare angle measured at a point on the bow door  $\ell/2$  aft of the stem line on a plane  $h/2$  above the bottom of the door as shown in 3-2-16/Figure 2.
- $\alpha_m$  = entry angle measured at the same point as  $\beta_m$ . See 3-2-16/Figure 2.
- $h$  = height, in m (ft), of the door between the levels of the bottom of the door and the upper deck or between the bottom of the door and the top of the door, whichever is less
- $\ell$  = fore and aft length, in m (ft), of the door at a height  $h/2$  above the bottom of the door

**FIGURE 2**  
**Definition of  $\alpha_m$  and  $\beta_m$**



## 19.5 Visor Door Forces, Moments and Load Cases

### 19.5.1 Closing Moment

For visor doors, the closing moment,  $M_y$ , is to be taken as indicated by the following equation:

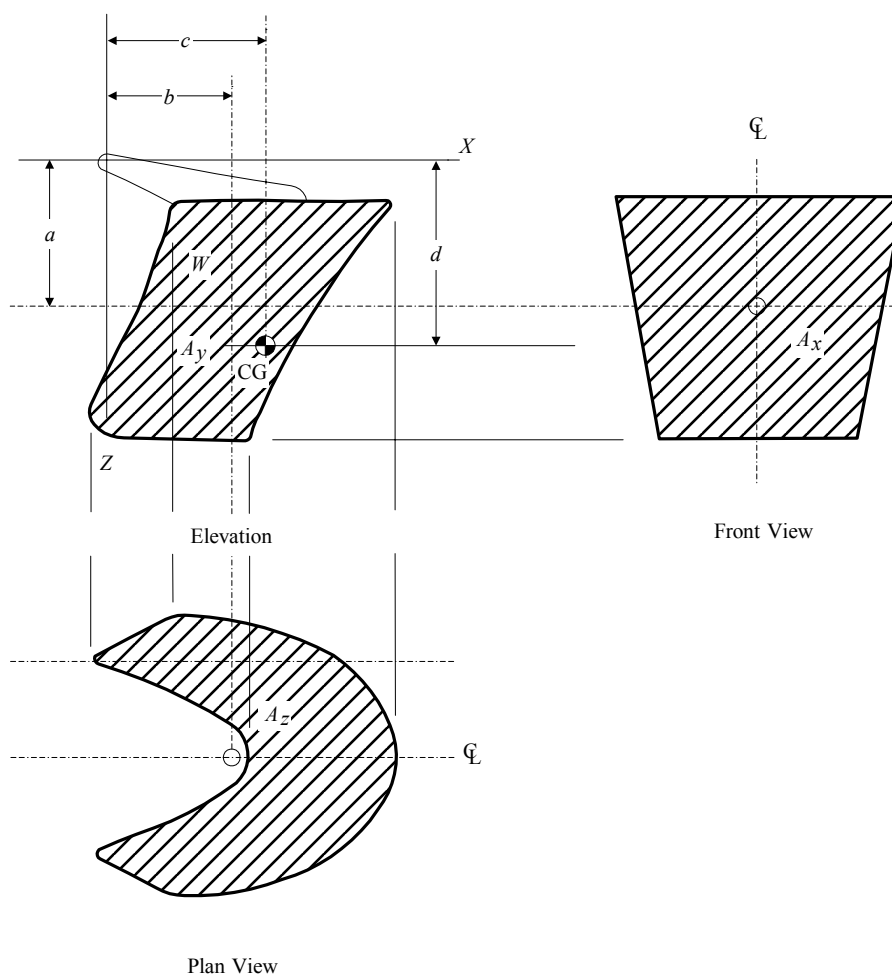
$$M_y = F_x a + Wc - F_z b \quad \text{kN-m (tf-m, Ltf-ft)}$$

where

- $W$  = weight of the visor door, in kN (tf, Ltf)
- $a$  = vertical distance, in m (ft), from the visor pivot to the centroid of the transverse vertical projected area of the visor door. See 3-2-16/Figure 3.
- $b$  = horizontal distance, in m (ft.), from visor pivot to the centroid of the horizontal projected area of the visor door. See 3-2-16/Figure 3.
- $c$  = horizontal distance, in m (ft.), from the visor pivot to the center of gravity of the visor. See 3-2-16/Figure 3.

$F_x$  and  $F_z$  are as defined in 3-2-16/19.3.

**FIGURE 3**  
**Visor Type Bow Door**



### 19.5.2 Opening Moment

The opening moment,  $M_o$ , is to be taken as indicated by the following equation:

$$M_o = Wd + 5A_x a \quad \text{kN-m} \quad (Wd + 0.5A_x a \quad \text{tf-m}, Wd + 0.047A_x a \quad \text{Ltf-ft})$$

where

$d$  = vertical distance, in m (ft), from the hinge axis to the center of gravity of the door.

$W$ ,  $A_x$  and  $a$  are as indicated above.

### 19.5.3 Vertical design Force

The vertical design force is to be taken as  $F_z - W$  where  $F_z$  is as defined in 3-2-16/19.3 and  $W$  is as defined in 3-2-16/19.5.1.

### 19.5.4 Combined Load Case 1

The visor doors are to be evaluated under a load of  $F_x$ ,  $F_z$  and  $W$  acting simultaneously with  $F_x$  and  $F_z$  acting at the centroid of their respective projected areas.

### 19.5.5 Combined Load Case 2

The visor doors are to be evaluated under a load of  $0.7F_y$  acting on each side separately, together with  $0.7F_x$ ,  $0.7F_z$  and  $W$ .  $F_x$ ,  $F_y$  and  $F_z$  are to be taken as acting at the centroid of their of their respective projected areas.

## 19.7 Side-Opening Door Load Cases

### 19.7.1 Combined Load Case 1

Side opening doors are to be evaluated under a load of  $F_x$ ,  $F_y$ ,  $F_z$  and  $W$  acting simultaneously with  $F_x$ ,  $F_y$  and  $F_z$  acting at the centroid of their respective projected areas.

### 19.7.2 Combined Load Case 2

Side opening doors are to be evaluated under a load of  $0.7F_x$ ,  $0.7F_x$  and  $W$  acting on both doors simultaneously and  $0.7F_y$  acting on each door separately.

## 21 Inner Door Design Loads

### 21.1 External Pressure

The design external pressure is to be taken as the greater of  $P_{ei}$  or  $P_h$ , as given by the following equations:

$$P_{ei} = 0.45L_1 \quad \text{kN/m}^2 \quad (0.046L_1 \quad \text{tf/m}^2, 0.00128L_1 \quad \text{Ltf/ft}^2)$$

$$P_h = 10h \quad \text{kN/m}^2 \quad (1.0h \quad \text{tf/m}^2, 0.029h \quad \text{Ltf/ft}^2)$$

where

$L_1$  is as defined in 3-2-16/19.1.

$h$  = the distance, in m (ft), from the load point to the top of the cargo space.

### 21.3 Internal Pressure

The design internal pressure,  $P_i$ , is to be taken as not less than  $25 \text{ kN/m}^2$  ( $2.5 \text{ tf/m}^2$ ,  $0.23 \text{ Ltf/ft}^2$ ).

## 23 Side Shell and Stern Doors (1998)

### 23.1 Design Forces for Primary Members

The design force, in kN (tf, Ltf), for primary members is to be the greater of the following:

$$\text{External force: } F_e = A p_e$$

$$\text{Internal force: } F_i = F_o + W$$

### 23.3 Design Forces for Securing or Supporting Devices of Doors Opening Inwards

The design force, in kN (tf, Ltf), for securing or supporting devices of doors opening inwards is to be the greater of the following:

$$\text{External force: } F_e = A p_e + F_p$$

$$\text{Internal force: } F_i = F_o + W$$

### 23.5 Design Forces for Securing or Supporting Devices of Doors Opening Outwards

The design force, in kN (tf, Ltf), for securing or supporting devices of doors opening outwards is to be the greater of the following:

$$\text{External force: } F_e = A p_e$$

$$\text{Internal force: } F_i = F_o + W + F_p$$

where

$A$  = area, in  $\text{m}^2$  ( $\text{ft}^2$ ), of the door opening

$W$  = weight of the door, in kN (tf, Ltf)

$F_p$  = total packing force, in kN (tf, Ltf). Packing line pressure is normally not to be taken less than 5.0 N/mm (0.51 kg/mm, 28.6 lbf/in).

$F_o$  = the greater of  $F_c$  and  $kA$ , in kN (tf, Ltf)

$k$  = 5 (0.51, 0.047)

$F_c$  = accidental force, in kN (tf, Ltf), due to loose cargo, etc., to be uniformly distributed over the area  $A$  and not to be taken less than 300 kN (30.6 tf, 30.1 Ltf). For small doors such as bunker doors and pilot doors, the value of  $F_c$  may be appropriately reduced. However, the value of  $F_c$  may be taken as zero, provided an additional structure such as an inner ramp is fitted which is capable of protecting the door from accidental forces due to loose cargoes.

$p_e$  = external design pressure, in  $\text{kN/m}^2$  ( $\text{tf/m}^2$ ,  $\text{Ltf/ft}^2$ ), determined at the center of gravity of the door opening and not taken less than:

$$p_e = k_1 \quad \text{for } Z_G \geq d$$

$$p_e = k_2(d - Z_G) + k_1 \quad \text{for } Z_G < d$$

Moreover, for vessels fitted with bow doors,  $p_e$  for stern doors is not to be taken less than:

$$p_e = nc(0.8 + 0.6(k_3L)^{0.5})^2$$

For vessels fitted with bow doors and operating in restricted service, the value of  $p_e$  for stern doors will be specially considered.

$k_1$	=	25.0 (2.55, 0.233)
$k_2$	=	10.0 (1.02, 0.0284)
$d$	=	draft, in m (ft), as defined in 3-1-1/9
$Z_G$	=	height of the center of area of the door, in m (ft), above the baseline.
$n$	=	0.605 (0.0616, 0.00563)
$c$	=	1
$k_3$	=	1.0 (1.0, 0.305)
$L$	=	length of vessel, in m (ft), as defined in 3-1-1/3.1, but need not be taken as greater than 200 m (656 ft).

## 25 Allowable Stresses

### 25.1 Primary Structure and Securing and Supporting Devices

The following stresses are not to be exceeded under the loads indicated above.

Shear Stress:  $\tau = 80/Q \text{ N/mm}^2$  (  $8.2/Q \text{ kgf/mm}^2$ ,  $11600/Q \text{ psi}$ )

Bending Stress:  $\sigma = 120/Q \text{ N/mm}^2$  ( $12.2/Q \text{ kgf/mm}^2$ ,  $17400/Q \text{ psi}$ )

Equivalent Stress: ( $\sqrt{\sigma^2 + 3\tau^2}$ ):  $\sigma_e = 150/Q \text{ N/mm}^2$  ( $15.3/Q \text{ kgf/mm}^2$ ,  $21770/Q \text{ psi}$ )

where  $Q$  is as defined in 3-2-1/5.5.

### 25.3 Steel Securing and Supporting Devices Bearing Stress

For steel-to-steel bearings in securing and supporting devices, the nominal bearing pressure is not to exceed  $0.8\sigma_f$ , where  $\sigma_f$  is the yield stress of the bearing material.

### 25.5 Tensile Stress on Threaded Bolts

The tensile stress in threaded bolts is not to exceed  $125/Q \text{ N/mm}^2$  ( $12.7/Q \text{ kgf/mm}^2$ ,  $18000/Q \text{ psi}$ ).

## 27 Operating and Maintenance Manual

The following information is to be submitted for review.

### 27.1 Manual (1998)

An operating and maintenance manual for the doors is to be provided onboard and is to contain at least the following:

- Main particulars and design drawings
- Service conditions, e.g., service area restrictions, emergency operations, acceptable clearances for supports
- Maintenance and function testing
- Register of inspections and repairs

### 27.3 Operating Procedures (1998)

Documented operating procedures for closing and securing the doors are to be kept onboard and posted at an appropriate location.

This Page Intentionally Left Blank



PART

# 3

CHAPTER **2 Hull Structures and Arrangements**

SECTION **17 Bulwarks, Rails, Freeing Ports, Portlights, Ventilators, Tank Vents and Overflows**

## **1 Bulwarks and Guard Rails**

### **1.1 Height on Manned Vessels**

The height of bulwarks and guard rails on exposed parts of freeboard and superstructure decks is to be at least 1 m (39.5 in.) from the deck. Where this height would interfere with the normal operation of the vessel, a lesser height may be approved if adequate protection is provided. Where approval of a lower height is requested, justifying information is to be submitted.

### **1.3 Strength of Bulwarks**

Bulwarks are to be of ample strength in proportion to their height and are to be efficiently stiffened at the upper edge. Bulwark plating on freeboard decks is not to be less than 6.5 mm (0.25 in.) in thickness. The bulwark plating is to be kept clear of the sheer strake and the lower edge effectively stiffened. Bulwarks are to be supported by efficient stays; those on freeboard decks are to have stays spaced not more than 1.83 m (6 ft) apart. The stays are to be formed of plate and angle or built-up tee sections and are to be efficiently attached to the bulwark and deck plating. Where it is intended to carry timber deck cargoes, the bulwark stays are to be not over 1.52 m (5 ft) apart and have increased attachment to deck and bulwark. Gangways and other openings in bulwarks are to be kept well away from breaks of superstructures, and heavy plates are to be fitted in way of mooring pipes.

### **1.5 Spacing of Guard Rails**

#### **1.5.1 (1998)**

Fixed, removable or hinged stanchions are to be fitted at approximately 1.5 m (5 ft) apart. Removable or hinged stanchions are to be capable of being locked in the upright position.

#### **1.5.2**

At least every third stanchion is to be supported by a bracket or stay.

1.5.3

The opening below the lowest course is not to exceed 230 mm (9 in.). The distance between the remaining courses is not to be more than 380 mm (15 in.).

1.5.4

For vessels with rounded gunwales, stanchions are to be placed on the flat of the deck.

### **3 Access and Crew Protection** *(1 July 1998)*

#### **3.1 General**

Vessels with the keel laid or in similar stage of construction on or after 1 July 1998 are to meet the following requirements. Satisfactory means in the form of guard rails, lifelines, gangways or underdeck passages, etc., are to be provided for the protection of the crew in getting to and from their quarters, the machinery space, and all other parts used in the necessary work of the vessel. See 3-2-17/Table 1

#### **3.3 Access to Bow on Tankers**

Tankers, including oil carriers, fuel oil carriers, gas carriers and chemical carriers, are to be provided with means to enable the crew to gain safe access to the bow even in severe weather conditions.

**TABLE 1**  
**Acceptable Arrangement for Access (2002)**

Type of Vessel	Locations of access in Vessel	Assigned Summer Freeboard	Acceptable arrangements according to type of freeboard assigned			
			Type A	Type B-100	Type B-60	Type B & B+
All Vessels other than Oil Tankers*, Chemical Tankers* and Gas Carriers*	<b>1.1: Access to Midship Quarters</b>	≤ 3000 mm (≤ 118 in.)	a	a	a	a
	<b>1.1.1:</b> Between poop and bridge, or		b	b	b	b
	<b>1.1.2:</b> Between poop and deckhouse containing living accommodation, or navigation equipment, or both.	> 3000 mm (> 118 in.)	e	e	c(1)	c(1)
					e	c(2)
					f(1)	c(4)
			a	a	a	d(1)
			b	b	b	d(2)
			e	e	c(1)	d(3)
					c(2)	e
					e	f(1)
				f(1)	f(2)	
				f(2)	f(4)	
All Vessels other than Oil Tankers*, Chemical Tankers* and Gas Carriers*	<b>1.2: Access to Ends</b>	≤ 3000 mm (≤ 118 in.)	a	a	a	
	<b>1.2.1:</b> Between poop and bow (if there is no bridge), or		b	b	b	
	<b>1.2.2:</b> Between bridge and bow, or	> 3000 mm (> 118 in.)	c(1)	c(1)	c(1)	c(1)
			e	c(2)	c(2)	c(2)
	<b>1.2.3:</b> Between a deckhouse containing living accommodation or navigation equipment, or both, and bow, or	> 3000 mm (> 118 in.)	f(1)	e	e	e
				f(1)	f(1)	f(1)
	<b>1.2.4:</b> In the case of a flush deck vessel, between crew accommodation and the forward and after ends of vessel.	> 3000 mm (> 118 in.)		f(2)	f(2)	f(2)
			a	a	a	
b			b	b		
c(1)			c(1)	c(1)	c(1)	
		d(1)	c(2)	c(2)	c(2)	
		e	d(1)	c(4)	d(1)	
		f(1)	d(2)	d(1)	d(2)	
			e	d(2)	e	
			f(1)	d(3)	f(1)	
				f(2)	f(2)	
				f(4)	f(4)	
Oil Tankers*, Chemical Tankers* and Gas Carriers*	<b>2.1: Access to Bow</b>	≤ ( $A_f + H_s$ )**				
	<b>2.1.1:</b> Between poop and bow, or		a			
	<b>2.1.2:</b> Between a deckhouse containing living accommodation or navigation equipment, or both, and bow, or	> ( $A_f + H_s$ )**	e			
			f(1)			
<b>2.1.3:</b> In the case of a flush deck vessel, between crew accommodation and the forward end of vessel.	> ( $A_f + H_s$ )**	f(5)				
		a				
		e				
		f(1)				
		f(2)				
	<b>2.2: Access to After End</b>		As required in 1.2.4 for other types of vessels			
	In the case of a flush deck vessel, between crew accommodation and the after end of vessel.					

\* Oil Tanker, Chemical Tanker and Gas Carrier as defined in SOLAS: II-1/2.12, VII/8.2 and VII/11.2 respectively.

\*\*  $A_f$ : the minimum summer freeboard calculated as type A ship regardless of the type freeboard actually assigned.

$H_s$ : the standard height of superstructure as defined in ICLL Regulation 33.

Note: Deviations from some or all of these requirements or alternative arrangements for such cases as vessels with very high gangways (i.e.: certain gas carriers) may be allowed, subject to agreement on a case-by-case basis with the relevant Flag Administration.

**TABLE 1 (continued)**  
**Acceptable Arrangement for Access (2002)**

**I. Construction Keys (a) through (f)**

- (a) A well lighted and ventilated underdeck passageway with clear opening at least 0.8 m (2.6 ft) in width and 2.0 m (6.6 ft) in height, providing access to the locations in question and located as close as practicable to the freeboard deck. For tankers, see also 5-1-7/17.5, 5-1-7/31.5, 5-1-7/31.9, 5-1-7/31.11 and 5-1-7/31.17.
- (b) A permanently constructed gangway fitted at or above the level of the superstructure deck on or as near as practicable to the center line of the vessel, providing a continuous platform of a non-slip surface at least 0.6 m (2 ft) in width, with a foot-stop and guard rails extending on each side throughout its length. Guard rails are to be as required in 3-2-17/3.1 and 3-2-17/1.5, except that stanchions are to be fitted at intervals not more than 1.5 m (5 ft).
- (c) A permanent walkway at least 0.6 m (2 ft) in width fitted at freeboard deck level consisting of two rows of guard rails with stanchions spaced not more than 3 m (10 ft). The number of courses of rails and their spacing are to be as required in 3-2-17/1.5. On Type B ships, hatchway coamings not less than 0.6 m (2 ft) in height may be regarded as forming one side of the walkway, provided that two rows of guard rails are fitted between the hatchways.
- (d) A 10 mm (0.4 in.) minimum diameter wire rope lifeline supported by stanchions about 10 m (33 ft) apart, or  
 A single hand rail or wire rope attached to hatch coamings, continued and adequately supported between hatchways.
- (e) A permanently constructed gangway fitted at or above the level of the superstructure deck on or as near as practicable to the center line of the vessel:
  - located so as not to hinder easy access across the working areas of the deck;
  - providing a continuous platform at least 1.0 m (3.3 ft) in width\*;
  - constructed of fire resistant and non-slip material;
  - fitted with guard rails extending on each side throughout its length. Guard rails are to be as required in 3-2-17/3.1 and 3-2-17/1.5, except that stanchions are to be fitted at intervals not more than 1.5 m (5 ft);
  - provided with a foot stop on each side;
  - having openings, with ladders where appropriate, to and from the deck. Openings are to be not more than 40 m (131 ft) apart;
  - having shelters of substantial construction, set in way of the gangway at intervals not exceeding 45 m (148 ft) if the length of the exposed deck to be traversed exceeds 70 m (230 ft). Every such shelter is to be capable of accommodating at least one person and be so constructed as to afford weather protection on the forward, port and starboard sides.
- (f) A permanent and efficiently constructed walkway fitted at freeboard deck level on or as near as practicable to the center line of the vessel having the same specifications as those for a permanent gangway listed in (e)\*, except for foot-stops. On Type B ships certified for the carriage of liquids in bulk, the hatch coamings may be accepted as forming one side of the walkway, provided a combined height of hatch coaming and hatch cover in the closed condition is not less than 1 m (3.3 ft) and two rows of guard rails are fitted between the hatchways.

(\* ) For tankers less than [100 m (328 ft)] in length, the minimum width of the gangway platform or deck level walkway fitted in accordance with arrangement (e) or (f), respectively, may be reduced to 0.6 m (2 ft).

**II. Transverse Location Keys (1) through (5) - for Construction (c), (d) and (f) where specified in the Table**

- (1) At or near the centerline of vessel or fitted on hatchways at or near the centerline of vessel.
- (2) Fitted on each side of the vessel.
- (3) Fitted on one side of the vessel, provision being made for fitting on either side.
- (4) Fitted on one side only.
- (5) Fitted on each side of the hatchways as near to the centerline as practicable.

**III. Notes:**

- 1. In all cases where wire ropes are fitted, adequate devices are to be provided to enable maintaining their tautness.
- 2. A means of passage over obstructions, if any, such as pipes or other fittings of a permanent nature is to be provided.
- 3. Generally, the width of the gangway or walkway should not exceed 1.5 m (5 ft).

## 5 Freeing Ports

### 5.1 Basic Area

Where bulwarks on the weather portions of freeboard or superstructure decks form wells, ample provision is to be made for rapidly freeing the decks of water and for draining them. Except as provided in 3-2-17/5.3 and 3-2-17/5.5, the minimum freeing-port area  $A$  on each side of the vessel for each well on the freeboard deck is to be obtained from the following equations in cases where the sheer in way of the well is standard or greater than standard (Standard sheer as defined in the International Convention on Load Lines, 1966). The minimum area for each well on superstructure decks is to be one-half of the area obtained from the following equation:

Where the length of bulwark  $\ell$  in the well is 20 m (66 ft) or less:

$$A = 0.7 + 0.035\ell \text{ m}^2 \qquad A = 7.6 + 0.115\ell \text{ ft}^2$$

Where  $\ell$  exceeds 20 m (66 ft):

$$A = 0.07\ell \text{ m}^2 \qquad A = 0.23\ell \text{ ft}^2$$

In no case need  $\ell$  be taken as greater than  $0.7L_f$  where  $L_f$  is as defined in 3-1-1/3.3. If the bulwark is more than 1.2 m (3.9 ft) in average height, the required area is to be increased by 0.004 m<sup>2</sup> per m (0.04 ft<sup>2</sup> per ft) of length of well for each 0.1 m (1 ft) difference in height. If the bulwark is less than 0.9 m (3 ft) in average height, the required area may be decreased by 0.004 m<sup>2</sup> per m (0.04 ft<sup>2</sup> per ft) of length of well for each 0.1 m (1 ft) difference in height.

### 5.3 Vessels with Less than Standard Sheer

In vessels with no sheer, the calculated area is to be increased by 50%. Where the sheer is less than the standard, the percentage is to be obtained by interpolation.

### 5.5 Trunks

Where a vessel is fitted with a trunk, and open rails are not fitted on weather parts of the freeboard deck in way of the trunk for at least half their length, or where continuous or substantially continuous hatchway side coamings are fitted between detached superstructures, the minimum area of the freeing-port openings is to be calculated from the following table.

<i>Breadth of hatchway or trunk in relation to the breadth of vessel</i>	<i>Area of freeing ports in relation to the total area of the bulwarks</i>
40% or less	20%
75% or more	10%

The area of freeing ports at intermediate breadths is to be obtained by linear interpolation.

### 5.7 Open Superstructures

In vessels having superstructures which are open at either or both ends, adequate provision for freeing the space within such superstructures is to be provided, and the arrangements are to be subject to special approval.

## 5.9 Details of Freeing Ports

The lower edges of the freeing ports are to be as near the deck as practicable. Two-thirds of the freeing-port area required is to be provided in the half of the well nearest the lowest point of the sheer curve. All such openings in the bulwarks are to be protected by rails or bars spaced approximately 230 mm (9 in.) apart. If shutters are fitted to freeing ports, ample clearance is to be provided to prevent jamming. Hinges are to have pins or bearings of noncorrodible material and in general are to be located at or near the top of the shutters. If shutters are fitted with securing appliances, these are to be of approved construction.

## 7 Portlights

### 7.1 Application (1 July 1998)

This subsection applies to passenger vessels and cargo vessels. See Paragraph 2/7.13 of the *ABS Guide for Building and Classing Passenger Vessels*. As such, any reference to bulkhead/freeboard deck means bulkhead deck in the case of passenger vessels and freeboard deck in the case of cargo vessels.

### 7.3 Location (1 July 1998)

No portlight is to be fitted in a position with its sill below a line drawn parallel to the bulkhead/freeboard deck at side and having its lowest point 2.5% of the breadth of the vessel above the load waterline (or summer timber load waterline, if assigned), or 500 mm (19.5 in.), whichever is the greater distance.

In addition, portlights are not to be fitted in spaces which are used exclusively for the carriage of cargo.

### 7.5 Construction (1 July 1998)

#### 7.5.1 General

Portlights to spaces below the bulkhead/freeboard deck or to spaces within enclosed superstructures are to be fitted with efficient hinged, inside deadlights arranged so that they can be effectively closed and secured watertight. The portlights, together with their glasses and deadlights, are to comply with a recognized standard. They are to have strong frames (other than cast iron) and opening-type portlights are to have noncorrosive hinge pins.

#### 7.5.2 Non-opening Type

Where vessels are subject to damage stability requirements of 3-3-1/3.3, portlights found to be situated below a final damage equilibrium waterline are to be of non-opening type.

#### 7.5.3 Locked Type

Portlights where permitted in 3-2-17/7.5.2 to be of opening type are to be of such construction as will prevent unauthorized opening where:

7.5.3(a) the sills of which are below the bulkhead/freeboard deck as permitted in 3-2-17/7.3, or

7.5.3(b) fitted in spaces used alternatively for the carriage of cargo or passengers.

#### 7.5.4 Automatic Ventilating Type

Automatic ventilating portlights are not to be fitted in the shell plating below the bulkhead/freeboard deck without special approval.

## 9 Ventilators, Tank Vents and Overflows (2004)

### 9.1 General (2004)

Ventilators are to comply with the requirements of 3-2-17/9.3. Tank vents and overflows are to comply with the requirements in 3-2-17/9.5. In addition, for those located on the fore deck, the requirements given in 3-2-17/9.7 are to be complied with.

### 9.3 Ventilators (2004)

#### 9.3.1 Construction of Coamings (2002)

Ventilators on exposed freeboard or superstructure decks to spaces below the freeboard deck or decks of enclosed superstructures are to have coamings of steel or other equivalent material. Coaming-plate thickness is not to be less than 7.5 mm (0.30 in.) for ventilators up to 200 mm (8 in.) in diameter, and 10 mm (0.40 in.) for diameters of 457 mm (18 in.) and above; the thicknesses for intermediate diameters may be obtained by interpolation. Coamings are to be effectively and properly secured to properly stiffened deck plating of sufficient thickness. Coamings which are more than 900 mm (35.5 in.) high and which are not supported by adjacent structures are to have additional strength and attachment. Ventilators passing through superstructures, other than enclosed superstructures, are to have substantially constructed coamings of steel at the freeboard deck. Where a fire damper is located within a ventilation coaming, an inspection port or opening at least 150 mm (6 in.) in diameter is to be provided in the coaming to facilitate survey of the damper without disassembling the coaming or the ventilator. The closure provided for the inspection port or opening is to maintain the watertight integrity of the coaming and, if appropriate, the fire integrity of the coaming.

#### 9.3.2 Height of Coamings

Ventilators in Position 1 are to have coamings at least 900 mm (35.5 in.) above the deck. Ventilators in Position 2 are to have coamings at least 760 mm (30 in.) above the deck. (See 3-2-15/3 for definition of Positions 1 and 2.) In exposed positions, the height of coamings may be required to be increased.

#### 9.3.3 Means for Closing Openings

Except as provided below, ventilator openings are to be provided with efficient, permanently attached closing appliances. Ventilators in Position 1, the coamings of which extend to more than 4.5 m (14.8 ft) above the deck, and in Position 2, the coamings of which extend to more than 2.3 m (7.5 ft) above the deck, need not be fitted with closing arrangements unless unusual features of the design make it necessary. See also 4-7-2/1.9.5 and 4-7-2/1.9.6.

### 9.5 Tank Vents and Overflows (2004)

Tank vents and overflows are to be in accordance with the requirements of 4-6-4/9.3 and 4-6-4/9.5 of these Rules. In addition, where applicable, the requirements given below in 3-2-17/9.7 are to be complied with.

### 9.7 Ventilators, Tank Vents and Overflows on the Fore Deck (2004)

#### 9.7.1 Application

The requirements of this paragraph apply to all ventilators, tank vents and overflows located on the exposed fore deck within the forward  $0.25L$  and where the height of the exposed deck in way of the item is less than  $0.1L$  or 22 meters (72 ft) above the summer load waterline, whichever is the lesser.

### 9.7.2 Applied Loading to the Air Pipes and Ventilators

9.7.2(a) *Pressure.* The pressures  $p$ , in kN/m<sup>2</sup> (tf/m<sup>2</sup>, Ltf/ft<sup>2</sup>), acting on air pipes, ventilator pipes and their closing devices, may be calculated from:

$$p = f \rho V^2 C_d C_s C_p \quad \text{kN/m}^2 \text{ (tf/m}^2, \text{ Ltf/ft}^2\text{)}$$

where:

- $f$  = 0.5 (0.05, 0.0156)
- $\rho$  = density of sea water, 1.025 t/m<sup>3</sup> (1.025 t/m<sup>3</sup>, 0.0286 Lt/ft<sup>3</sup>)
- $V$  = velocity of water over the fore deck, 13.5 m/sec (44.3 ft/sec)
- $C_d$  = shape coefficient
  - = 0.5 for pipes
  - = 1.3 for pipes or ventilator heads in general
  - = 0.8 for pipes or ventilator heads of cylindrical form with their axis in the vertical direction
- $C_s$  = slamming coefficient, 3.2
- $C_p$  = protection coefficient:
  - = 0.7 for pipes and ventilator heads located immediately behind a breakwater or forecastle
  - = 1.0 elsewhere, including immediately behind a bulwark

9.7.2(b) *Force.* Forces acting in the horizontal direction on the pipe and its closing device may be calculated from the above pressure using the largest projected area of each component.

### 9.7.3 Strength Requirements for Ventilators, Tank Vents and Overflows and their Closing Devices

9.7.3(a) *Bending Moment and Stress.* Bending moments and stresses in air pipes and ventilator pipes are to be calculated at critical positions: at penetration pieces, at weld or flange connections, at toes of supporting brackets. Bending stresses in the net section are not to exceed 0.8 $Y$ , where  $Y$  is the specified minimum yield stress or 0.2% proof stress of the steel at room temperature. Irrespective of corrosion protection, a corrosion addition to the net section of 2.0 mm (0.08 in.) is then to be applied.

#### 9.7.3(b) Tank Vents and Overflows

- i) For standard tank vents and overflows of 760 mm (30 in.) height closed by heads of not more than the tabulated projected area, pipe thicknesses and bracket heights are specified in 3-2-17/Table 2. Where brackets are required, three or more radial brackets are to be fitted.
- ii) Brackets are to be of gross thickness of 8 mm (0.32 in.) or more, of minimum length of 100 mm (4.0 in.), and height according to 3-2-17/Table 2, but need not extend over the joint flange for the head. Bracket toes at the deck are to be suitably supported.
- iii) For other configurations, loads according to 3-2-17/9.7.2 are to be applied, and means of support determined in order to comply with the requirements above. Brackets, where fitted, are to be of suitable thickness and length according to their height.
- iv) Final (gross) pipe thickness is not to be taken less than as indicated in 4-6-4/9.3.2 and 4-6-4/9.5.6.
- v) The minimum internal diameter of the air pipe or overflow is not to be less than 65 mm.



9.7.3(c) Ventilators

- i) For standard ventilators of 900 mm (35.4 in.) height closed by heads of not more than the tabulated projected area, pipe thicknesses and bracket heights are specified in 3-2-17/Table 3. Brackets, where required, are to be as specified in 3-2-17/9.7.3(b)iii.
- ii) For ventilators of height greater than 900 mm (35.4 in.), brackets or alternative means of support are to be provided. Coamings are not to be taken less than as indicated in 3-2-17/9.3 nor in 3-2-17/Table 2.

9.7.3(d) Components and Connections. All component parts and connections of the tank vents and overflows or ventilators are to be capable of withstanding the loads defined in 3-2-17/9.7.2.

9.7.3(e) Rotary Heads. Rotating type mushroom ventilator heads are not to be used for applications in this location

**TABLE 2**  
**760 mm (30 in.) High Tank Vents and Overflows**  
**Thickness and Bracket Standards (2004)**

Nominal Pipe Size		Minimum Fitted Gross Thickness		Maximum Projected Area of Head		Height <sup>(1)</sup> of Brackets	
A	B						
mm	in.	mm	in.	cm <sup>2</sup>	in <sup>2</sup>	mm	in.
65	2½	6.0	---	---	---	480	18.9
80	3	6.3	0.25	---	---	460	18.1
100	4	7.0	0.28	---	---	380	15.0
125	5	7.8	0.31	---	---	300	11.8
150	6	8.5	0.33	---	---	300	11.8
175	7	8.5	0.33	---	---	300	11.8
200	8	8.5 <sup>(2)</sup>	0.33 <sup>(2)</sup>	1900	295	300	11.8
250	10	8.5 <sup>(2)</sup>	0.33 <sup>(2)</sup>	2500	388	300 <sup>(2)</sup>	11.8 <sup>(2)</sup>
300	12	8.5 <sup>(2)</sup>	0.33 <sup>(2)</sup>	3200	496	300 <sup>(2)</sup>	11.8 <sup>(2)</sup>
350	14	8.5 <sup>(2)</sup>	0.33 <sup>(2)</sup>	3800	589	300 <sup>(2)</sup>	11.8 <sup>(2)</sup>
400	16	8.5 <sup>(2)</sup>	0.33 <sup>(2)</sup>	4500	698	300 <sup>(2)</sup>	11.8 <sup>(2)</sup>

Notes:

- 1 Brackets [see 3-2-17/9.7.3(b)] need not extend over the joint flange for the head.
- 2 Brackets are required where the as fitted (gross) thickness is less than 10.5 mm (0.41 in.) or where the tabulated projected head area is exceeded.

Note: For other air pipe heights, the relevant requirements of 3-2-17/9.7.3 are to be applied.

**TABLE 3**  
**900 mm (35.4 in.) High Ventilator**  
**Thickness and Bracket Standards (2004)**

Nominal Pipe Size		Minimum Fitted Gross Thickness		Maximum Projected Area of Head		Height <sup>(1)</sup> of Brackets	
A	B	mm	in.	cm <sup>2</sup>	in <sup>2</sup>	mm	in.
mm	in.	mm	in.	cm <sup>2</sup>	in <sup>2</sup>	mm	in.
80	3	6.3	0.25	-	-	460	18.1
100	4	7.0	0.28	-	-	380	15.0
150	6	8.5	0.33	-	-	300	11.8
200	8	8.5	0.33	550	85	-	-
250	10	8.5	0.33	880	136	-	-
300	12	8.5	0.33	1200	186	-	-
350	14	8.5	0.33	2000	310	-	-
400	16	8.5	0.33	2700	419	-	-
450	18	8.5	0.33	3300	511	-	-
500	20	8.5	0.33	4000	620	-	-

Note: For other ventilator heights, the relevant requirements of 3-2-17/9.7.3 are to be applied.

PART

# 3

CHAPTER **2 Hull Structures and Arrangements**

SECTION **18 Ceiling, Sparring and Protection of Steel**

**1 Close Ceiling (1997)**

Ceiling, where fitted, is to be laid either directly on a tightening and preserving compound or on battens. On vessels with sloping margin plate, the ceiling from the margin plate to the upper part of the bilge is to be arranged so as to be readily removable for inspection. Except for holds intended exclusively for the carriage of containers on the inner bottom, ceiling is to be fitted under all hatchways unless the inner bottom plating is increased by at least 2 mm (0.08 in.).

**3 Sparring**

Sparring is to be fitted to the sides above the bilge ceiling, if any, in all cargo spaces where it is intended to carry general cargo. The sparring is not to be less than 40 mm (1.625 in.) thick, finished, nor is it to provide less protection to the framing than is obtained from battens at least 140 mm (5.5 in.) wide, finished, and spaced 380 mm (15 in.) center to center. Sparring is to be bolted, fitted in cleats, or in portable frames for convenience in removal. Sparring may be omitted in vessels engaged in the carriage of coal, bulk cargoes, containers and similar cargoes. In such cases, the notation **NS** will be entered in the *Record*, indicating no sparring.

**5 Protection of Steel Work (1 Jan 1993)**

**5.1 All Spaces**

Unless otherwise approved, all steel work is to be suitably coated with paint or an equivalent.

**5.3 Salt Water Ballast Space (1994)**

Tanks or holds for salt water ballast are to have a corrosion resistant **hard coating** such as epoxy or zinc on all structural surfaces. Where a long retention of salt water ballast is expected due to the type of vessel or unit, special consideration for the use of inhibitors or sacrificial anodes may be given.

**5.5 Oil Spaces**

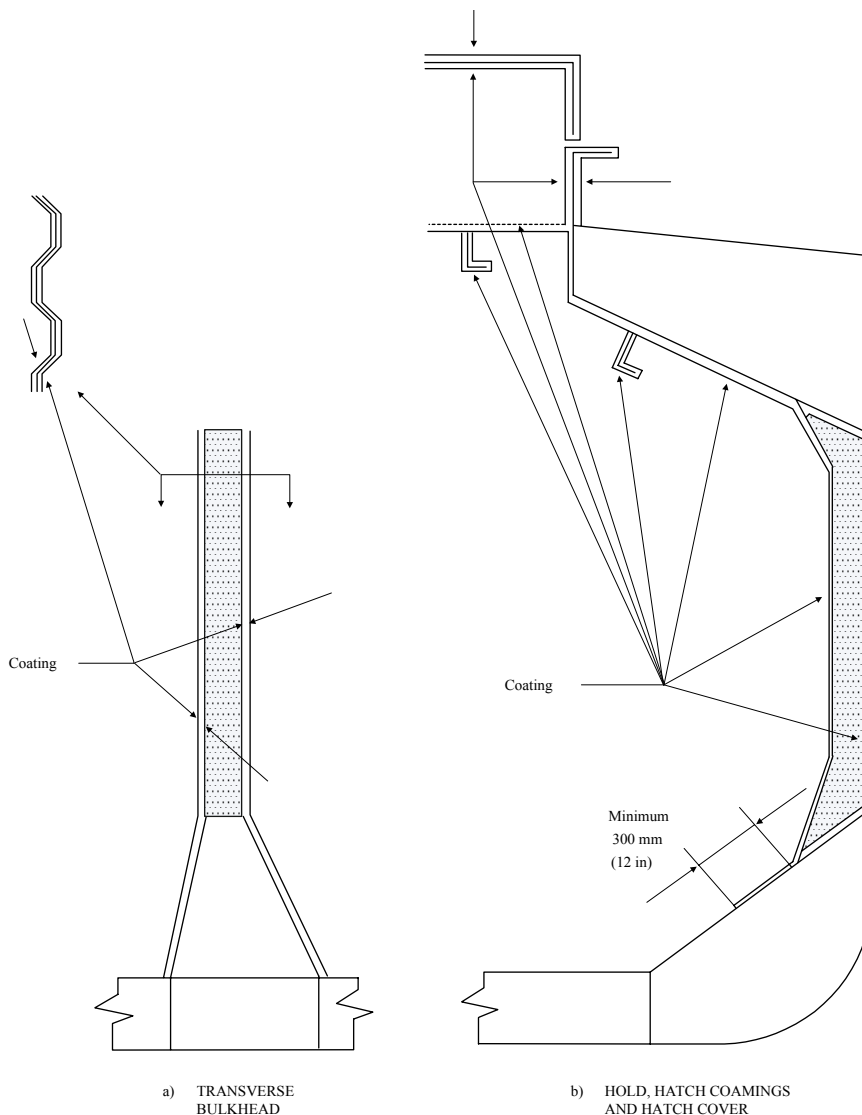
Tanks intended for oil or the holds of combination carriers intended for the carriage of dry bulk cargoes and oil cargoes need not be coated unless required by 3-2-18/5.7.

**5.7 Cargo Holds on Bulk Carriers (including Combination Carriers) (1998)**

All internal and external surfaces of hatch coamings and hatch covers, and all internal surfaces of cargo holds, excluding the flat tank top areas and the hopper tank sloping plating up to approximately 300 mm (12 in.) below the side shell frame end brackets, are to have an epoxy or equivalent coating applied in accordance with the manufacturer’s recommendations. The internal surface of the cargo hold includes those surfaces of stiffening members of the top wing tank bottom, where fitted on the hold side, and deck plating and associated beams, girders, etc. facing holds such as those between the main hatchways. See 3-2-18/Figure 1.

In the selection of coatings, due consideration is to be given by the Owner to the intended cargoes and conditions expected in service.

**FIGURE 1  
 Extent of Coatings (1998)**



PART

# 3

CHAPTER **2 Hull Structures and Arrangements**

SECTION **19 Weld Design**

## **1 Fillet Welds**

### **1.1 General**

#### **1.1.1 Plans and Specifications**

The actual sizes of fillet welds are to be indicated on detail drawings or on a separate welding schedule and submitted for approval in each individual case. In determining weld sizes based on the equations in this Section, the nearest  $1/2$  mm ( $1/32$  in.) may be used.

#### **1.1.2 Workmanship**

Completed welds are to be to the satisfaction of the attending Surveyor. The gaps between the faying surfaces of members being joined should be kept to a minimum. Where the opening between members being joined exceeds 2.0 mm (0.08 in.) and is not greater than 5 mm ( $3/16$  in.), the weld leg size is to be increased by the amount of the opening in excess of 2.0 mm (0.08 in.). Where the opening between members is greater than 5 mm ( $3/16$  in.), corrective procedures are to be specially approved by the Surveyor.

#### **1.1.3 Special Precautions**

Special precautions, such as the use of preheat or low-hydrogen electrodes or low-hydrogen welding processes, may be required where small fillets are used to attach heavy plates or sections. When heavy sections are attached to relatively light plating, the weld size may be required to be modified.

## **3 Tee Connections**

### **3.1 Size of Fillet Welds**

Tee connections are generally to be formed by continuous or intermittent fillet welds on each side, as required by 3-2-19/Table 1. The leg size,  $w$ , of fillet welds (see figure in 3-2-19/Table 1) is obtained from the following equations:

$$w = t_{p\ell} \times C \times \frac{s}{\ell} + 2.0 \text{ mm}$$

or

$$w = t_{p\ell} \times C \times \frac{s}{\ell} + 0.08 \text{ in.}$$

$$w_{\min} = 0.3t_{p\ell} \text{ or } 4.5 \text{ mm (0.18 in.) [4.0 mm (0.16 in.) where 3-2-19/9 is applicable],}$$

whichever is greater.

where

- $\ell$  = the actual length of weld fillet, clear of crater, in mm (in.)
- $s$  = the distance between successive weld fillets, from center to center, in mm (in.)
- $s/\ell$  = 1.0 for continuous fillet welding
- $t_{p\ell}$  = thickness of the thinner of the two members being joined, in mm (in.)
- $C$  = weld factors given in 3-2-19/Table 1

In selecting the leg size and spacing of matched fillet welds, the leg size for the intermittent welds is to be taken as not greater than the designed leg size  $w$  or  $0.7t_{p\ell} + 2.00 \text{ mm (} 0.7t_{p\ell} + 0.08 \text{ in.)}$ , whichever is less.

The throat size,  $t$ , is to be not less than  $0.70 w$ .

For the weld size for  $t_{p\ell}$  less than 6.5 mm (0.25 in.), see 3-2-19/3.11.

### 3.3 Length and Arrangement of Fillet

Where an intermittent weld is permitted by 3-2-19/Table 1, the length of each fillet weld is to be not less than 75 mm (3 in.) for  $t_{p\ell}$  of 7 mm (0.28 in.) or more, nor less than 65 mm (2.5 in.) for lesser  $t_{p\ell}$ . The unwelded length is to be not more than  $32t_{p\ell}$ .

### 3.5 Intermittent Welding at Intersection

Where beams, stiffeners, frames, etc. are intermittently welded and pass through slotted girders, shelves or stringers, there is to be a pair of matched intermittent welds on each side of each such intersection, and the beams, stiffeners and frames are to be efficiently attached to the girders, shelves and stringers.

### 3.7 Welding of Longitudinal to Plating

Welding of longitudinals to plating is to have double continuous welds at the ends and in way of transverses equal in length to depth of the longitudinal. For deck longitudinals only, a matched pair of welds is required at the transverses.

### 3.9 Stiffeners and Webs to Hatch Covers

Unbracketed stiffeners and webs of hatch covers are to be welded continuously to the plating and to the face plate for a length at ends equal to the end depth of the member.

### 3.11 Thin Plating

For plating of 6.5 mm (0.25 in.) or less, the requirements of 3-2-19/3.1 may be modified as follows:

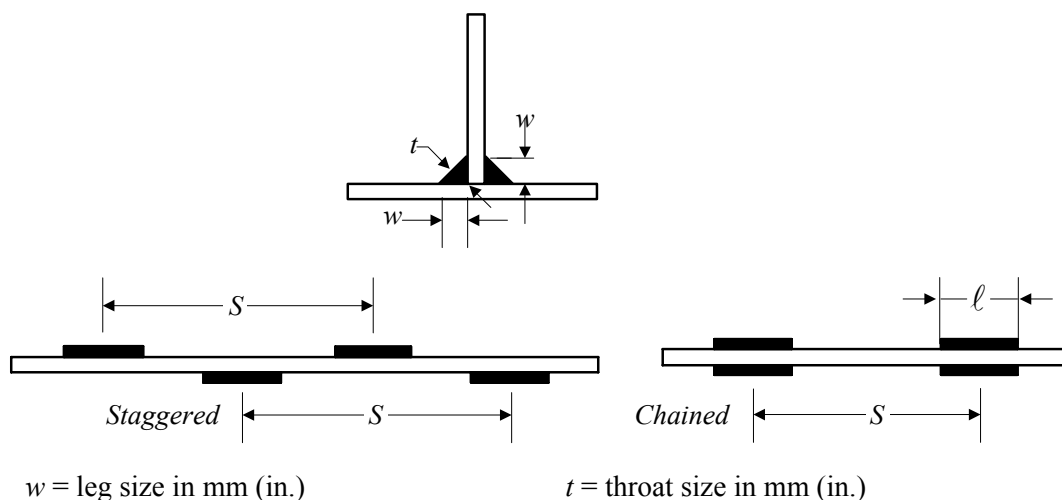
$$w = t_{pl} C \frac{S}{\ell} + 2.0 \left( 1.25 - \frac{\ell}{S} \right) \text{ mm}$$

$$w = t_{pl} C \frac{S}{\ell} + 0.08 \left( 1.25 - \frac{\ell}{S} \right) \text{ in.}$$

$$w_{\min} = 3.5 \text{ mm (0.14 in.)}$$

The use of the above equations for plating in excess of 6.5 mm (0.25 in.) may be specially considered depending upon the location and the quality control procedure.

**TABLE 1**  
**Weld Factors**



I. Periphery Connections		Factor C
		C = Continuous
		DC = Double Continuous
A. Tight Joints		
1.	Strength deck to sheer strake (See 3-2-19/15)	0.42 DC
2.	Main longitudinal bulkhead to deck, bottom or inner bottom (See 3-2-19/15)	0.42 DC
3.	All other tight joints except X.B. (See 3-2-9/7.5)	
	a. watertight bulkhead, $t_{pl} \leq 12.5 \text{ mm (0.50 in.)}$ where one side intermittent and the other side continuous	0.12 & 0.58 C
	where double continuous	0.35 DC
	b. all other joints	0.35 DC
B. Non-tight Joints		
1.	Platform decks	0.28 DC
2.	Swash bulkheads in deep tanks	0.20
3.	Non-tight bulkheads other than B2	0.15
II. Bottom Floors		
1.	To Shell (1993)	
	a. in aft peak below waterline	0.25 DC
	b. in machinery space	0.20 DC
	c. flat of bottom forward	0.15
	d. in aft peak above waterline and in forward peak	0.15
	e. elsewhere (See note 5)	0.12

**TABLE 1 (continued)**  
**Weld Factors**

<b>II. Bottom Floors (Continued)</b>		
2.	To Inner Bottom	
	a. in machinery space	0.20 DC
	b. at forward end (fore end strengthening)	0.15
	c. elsewhere (See note 5)	0.12
3.	To Center or Side Girder	
	a. in way of engine	0.30 DC
	b. with longitudinal framing	0.30 DC
	c. with transverse framing	0.17
4.	To Margin Plate, Side Shell, Longitudinal Bulkhead or Bilge	0.35 DC
5.	Open Floor Bracket	
	a. to center girder	0.15
	b. to margin plate	0.30 DC
<b>III. Bottom Girder</b>		
1.	Center Girder	
	a. to inner bottom in way of engine	0.30 DC
	b. to inner bottom clear of engine, non-tight	0.23
	c. to shell, non-tight	0.25 DC
2.	Side Girder	
	a. to floors in way of transverse bulkheads	0.35 DC
	b. to shell—flat of bottom forward	0.23
	—elsewhere	0.15
	c. to inner bottom—in way of engine	0.23
	—elsewhere	0.15
<b>IV. Web Frames, Stringers, Deck Girders and Deck Transverses</b>		
1.	To Plating	
	a. in tanks	0.20
	b. elsewhere	0.15
2.	To Face Plates	
	a. face area $\leq 64.5 \text{ cm}^2$ (10 in <sup>2</sup> )	0.12
	b. face area $> 64.5 \text{ cm}^2$ (10 in <sup>2</sup> )	0.15
3.	End Attachment	
	a. unbracketed (see note 1)	0.55 DC
	b. bracketed	0.40 DC
<b>V. Frames, Beams and Stiffeners</b>		
1.	To Shell (1993)	
	a. in aft peak below waterline	0.25 DC
	b. flat of bottom forward	0.25 DC
	c. 0.125L forward	0.15
	d. in aft peak above waterline and in forward peak	0.15
2.	Slab longitudinals (1998)	(see note 2)
3.	To plating elsewhere	0.12



**TABLE 1 (continued)  
Weld Factors**

<b>V. Frames, Beams and Stiffeners (Continued)</b>		
4.	End attachment	
	a. unbracketed (see note 1)	0.45 DC
	b. bracketed	0.35 DC
<b>VI. Hatch Covers</b>		
1.	Oiltight Joints	0.40 DC
2.	Watertight Joints	
	Outside	0.40 C
	Inside	0.15
3.	Stiffeners and Webs to Plating and to Face Plate (see note 4)	0.12
4.	Stiffeners and Web to Side Plating or other stiffeners	
	—unbracketed (see note 1)	0.45 DC
	—bracketed	0.35 DC
<b>VII. Hatch Coamings and Ventilators</b>		
1.	To Deck	
	a. at hatch corner	0.45 DC
	b. elsewhere	0.25 DC
2.	Coaming stays	
	a. to deck	0.20 DC
	b. to coaming	0.15 DC
<b>VIII. Foundations (See 3-2-19/15)</b>		
1.	Main Engine and Major Auxiliaries	0.40 DC
2.	Boilers and other Auxiliaries	0.35 DC
<b>IX. Rudders—Diaphragms</b>		
1.	To Side Plating	
	a. in way of rudder axis	0.45 DC
	b. elsewhere	0.20
	c. slot welds (see note 6)	0.45 DC
2.	To Diaphragms	
	a. to vertical diaphragms in way of rudder axis	0.45 DC
	b. elsewhere	0.20
	c. to top and bottom casting in way of rudder axis	Full penetration welds
<b>X. Additional Weld Factors for Oil Carriers and Similar Vessels</b>		
A.	Deep Supporting Members	
1.	To Bottom Shell	
	a. end quarter span	0.45 DC
	b. mid half span (See note 3)	0.40 DC
2.	To Deck	
	a. end quarter span	0.40 DC
	b. mid half span (See note 3)	0.35 DC
3.	To Side Shell and Longitudinal Bulkheads	0.40 DC
4.	To Transverse Bulkheads	

**TABLE 1 (continued)  
Weld Factors**

<b>X. Additional Weld Factors for Oil Carriers and Similar Vessels (Continued)</b>	
a. end quarter span	0.45 DC
b. mid half span	0.35 DC
5. To Face Plate	0.30 DC
B. Boundaries of Cargo Segregation (See 3-2-19/15 and 3-2-9/7)	0.42 DC
<b>XI. Additional Weld Factors for Double Hull Tankers (1998)</b>	
A. Deep Supporting Members in Double Hull (see General Notes 2)	
1. To Side Shell	0.20 DC
2. To Inner Skin Bulkhead	
a. in way of deck transverse/bracket	0.35 DC
b. in way of strut, as applicable	0.35 DC
c. elsewhere	0.20 DC
3. To Inner Bottom (floor)	
a. in way of longitudinal bulkhead web/bracket	0.45 DC
b. elsewhere	0.12 DC
4. To bottom side girder in way of bilge	0.35 DC
5. To horizontal shelf plate in way of bilge	0.35 DC
<b>XII. Additional Weld Factors for Single Side Skin Bulk Carriers (1998)</b>	
Factor C	
A. Transverse Hold Frames (see notes 1 and 7)	
1. To Side Shell	
a. End Quarter Span	$(0.63 - C_{pl}/t_{pl})DC$
b. Remainder	$(0.57 - C_{pl}/t_{pl})DC$
2. End Attachment (to sloping wing tank plating)	
a. bracketed	$(0.63 - C_{pl}/t_{pl})DC$
$C_{pl} = 2.00 (0.08) \text{ mm (in)}$	

*Notes*

- 1 The weld size is to be determined from the thickness of the member being attached.
- 2 (1998) Slab longitudinals within  $D_s/4$  from strength deck – For these slab longitudinals, the leg size  $w$  and  $w_{min}$  in 3-2-19/3.1 may both be taken as  $0.23t_{pl} + 1.0 \text{ mm } (0.23 t_{pl} + 0.04 \text{ in.})$  with a minimum of 4.5 mm (0.18 in.), but need not be greater than 8 mm. Where the slab longitudinal is located more than  $D_s/4$  from the strength deck, special consideration will be given to the weld size.
- 3 This may be applied only where the shearing forces over the mid-half span are no greater than one-half the maximum shearing-force on the member and where the web is of the same depth, clear of end brackets and of the same thickness throughout the length of the member. The weld size is to be determined from the thickness of member being attached.
- 4 Unbracketed stiffeners and webs of hatch covers are to be welded continuously to the plating and to the face plate for a length at ends equal to the end depth of the member.
- 5 With longitudinal framing, the weld size is to be increased to give an equivalent weld area to that obtained without cut-outs for longitudinals.
- 6 (1995) The weld size is to be determined from the thickness of the side plating.
- 7 (1998) Where the hull form is such that an effective fillet weld cannot be produced, edge preparation of the frame web and bracket may be required to provide the same efficiency of the connection.

*General Notes*

- 1 For oil carriers and similar vessels, the leg size in cargo tanks and in ballast tanks in the cargo area is not to be less than 6 mm (0.25 in.), except where approval has been given in accordance with 3-2-19/9
- 2 (1998) The weld size is to be increased for high stress areas which are to be confirmed by “Calculation of Structural Responses,” as specified in 5-1-5/9.

## 5 Tee-Type End Connections

Tee-type end connections where fillet welds are used are to have continuous welds on each side. In general, the leg sizes of the welds are to be in accordance with 3-2-19/Table 1 for unbracketed end attachment, but in special cases where heavy members are attached to relatively light plating, the sizes may be modified. Where only the webs of girders, beams and stiffeners are required to be attached to plating, it is recommended that the unattached face plate or flanges be cut back.

## 7 Ends of Unbracketed Stiffeners

Unbracketed stiffeners of shell, watertight and oiltight bulkheads and house fronts are to have double continuous welds for one-tenth of their length at each end.

Unbracketed stiffeners of non-tight structural bulkheads, deckhouse sides and after ends are to have a pair of matched intermittent welds at each end.

## 9 Reduced Weld Size

### 9.1 General

Reduction in fillet weld sizes, except for slab longitudinals of thickness greater than 25 mm (1.0 in.), may be specially approved by the Surveyor in accordance with either 3-2-19/9.3 or 3-2-19/9.5, provided that the requirements of 3-2-19/3 are satisfied.

### 9.3 Controlled Gaps

Where quality control facilitates working to a gap between members being attached of 1 mm (0.04 in.) or less, a reduction in fillet weld leg size  $w$  of 0.5 mm (0.02 in.) may be permitted.

### 9.5 Deep Penetration Welds

Where automatic double continuous fillet welding is used and quality control facilitates working to a gap between members being attached of 1 mm (0.04 in.) or less, a reduction in fillet weld leg size of 1.5 mm (0.06 in.) may be permitted, provided that the penetration at the root is at least 1.5 mm (0.06 in.) into the members being attached.

## 11 Lapped Joints

### 11.1 General

Lapped joints are generally to have overlaps of not less width than twice the thinner plate thickness plus 25 mm (1.0 in.).

### 11.3 Overlapped End Connections

Overlapped end connections of longitudinal strength members within the midship  $0.4L$  are to have continuous fillet welds on both edges each equal in size  $w$  to the thickness of the thinner of the two plates joined. All other overlapped end connections are to have continuous welds on each edge of size  $w$  such that the sum of the two is not less than 1.5 times the thickness of the thinner plate.

### **11.5 Overlapped Seams**

Overlapped seams are to have continuous welds on both edges of the sizes required by 3-2-19/Table 1 for the boundaries of deep tank or watertight bulkheads, except that for seams of plates 12.5 mm ( $1/2$  in.) or less clear of tanks one edge may have intermittent welds in accordance with 3-2-19/Table 1 for watertight bulkhead boundaries.

### **13 Plug Welds or Slot Welds**

Plug welds or slot welds may be specially approved for particular applications. Where used in the body of doublers and similar locations, such welds may be spaced about 305 mm (12 in.) between centers in both directions.

### **15 Full or Partial Penetration Corner or Tee Joints (1994)**

A full or partial penetration weld may be required for highly stressed (75% or more of the yield) or critical (e.g., oil/water boundary) joints.

Measures taken to achieve full or partial penetration corner or tee joints, where specified, are to be to the satisfaction of the attending Surveyor. The designer is to give consideration to minimize the possibility of lamellar tearing in such joints.

### **17 Alternatives**

The foregoing are considered minimum requirements for electric-arc welding in hull construction, but alternative methods, arrangements and details will be considered for approval. See 2-4-3/5. Fillet weld sizes may be determined from structural analyses based on sound engineering principles, provided that they meet the overall strength standards of the Rules.

**3 Subdivision and Stability****CONTENTS**

<b>SECTION 1</b>	<b>General Requirements.....</b>	<b>233</b>
1	General .....	233
3	Criteria .....	233
	3.1 Intact Stability.....	233
	3.3 Subdivision and Damage Stability.....	233
5	Review Procedures.....	234
	5.1 Administration Review.....	234
	5.3 Bureau Review.....	234
7	Damage Control Plan for Dry Cargo Vessels .....	234
9	Onboard Computers for Stability Calculations.....	234
<b>APPENDIX 1</b>	<b>Intact Stability of Tankers During Liquid Transfer Operations .....</b>	<b>235</b>
1	General .....	235
	1.1 Note .....	235
	1.3 Operations to be Addressed .....	235
<b>APPENDIX 2</b>	<b>Subdivision and Damage Stability Requirements for Bulk Carriers.....</b>	<b>239</b>
1	General .....	239
	1.1 Note .....	239
	1.3 Applicability .....	239
3	Damage Stability Criteria .....	239
5	Bulk Carriers with a Reduced Freeboard.....	240
<b>APPENDIX 3</b>	<b>Onboard Computers for Stability Calculations .....</b>	<b>241</b>
1	General .....	241
	1.1 Scope.....	241
	1.3 Design.....	241
3	Calculation Systems .....	241
5	Types of Stability Software .....	242

7	Functional Requirements .....	242
	7.1 Calculation Program .....	242
	7.3 Direct Damage Stability Calculations .....	242
	7.5 Warning .....	242
	7.7 Data Printout .....	242
	7.9 Date and Time .....	242
	7.11 Information of Program .....	243
	7.13 Units .....	243
9	Acceptable Tolerances .....	243
	9.1 Calculation Program of the Approved Stability Information .....	243
	9.3 Independent Program for Assessment of Stability .....	243
11	Approval Procedure .....	244
	11.1 Conditions of Approval of the Onboard Computers for Stability Calculations .....	244
	11.3 General Approval (optional) .....	245
	11.5 Specific Approval .....	245
13	Operation Manual .....	246
15	Installation Testing .....	246
17	Periodical Testing .....	247
19	Other Requirements .....	247
TABLE 1	Acceptable Tolerances .....	244

## PART

# 3

## CHAPTER 3 Subdivision and Stability

### SECTION 1 General Requirements

#### 1 General

Vessels of the following categories are to have subdivision and stability in accordance with the criteria as shown.

Attained subdivision index “A” calculated by The Bureau in accordance with Regulation II-1/25-4 of SOLAS 1974 as amended (see 3-3-1/3.3 for cargo vessels) will be published in the *Record*.

#### 3 Criteria

##### 3.1 Intact Stability (2002)

Vessels of applicable size, type and service are to have intact stability as required by Regulation 10 of the International Convention on Load Lines. The following criteria may be used for the purpose of classification:

- Cargo vessels of all sizes with or without deck cargo: Chapters 3.1, 3.2 and 4.1 of IMO Resolution A.749(18), as amended by IMO Resolution MSC.75(69)
- Offshore supply vessels of all sizes: Chapters 3.1, 3.2 and 4.5 of IMO Resolution A.749(18), as amended by IMO Resolution MSC.75(69)

Tankers of applicable size, type and service for which the building contract is placed on or after 1 February 1999 or, in the absence of a building contract, the keels of which are laid or which are in a similar stage of construction on or after 1 August 1999 are to have intact stability as required by Regulation 25A in Annex I of the International Convention for Prevention of Pollution from Ships, 1973/1978. Tankers for which that Regulation is not applicable are to meet the requirements in Appendix 3-3-A1, “Intact Stability of Tankers During Liquid Transfer Operations.”

##### 3.3 Subdivision and Damage Stability

Vessels of applicable size, type and service are to have subdivision and damage stability as required by the International Convention for the Safety of Life at Sea, 1974, as amended, as follows:

- Passenger vessel — Regulation II-1/4 through 8 (Section 3 of the *ABS Guide for Building and Classing Passenger Vessels*)
- Cargo vessel — Regulation II-1/25-1 through 25-8
- Gas carrier — IGC Code (ABS Rules Section 5-8-2)
- Chemical carrier — IBC Code (ABS Rules Section 5-9-2)

Bulk carriers for which the request for class for new construction is received on or after 1 July 1998 are to meet the requirements in Appendix 3-3-A2, "Subdivision and Damage Stability Requirements for Bulk Carriers."

## 5 Review Procedures

### 5.1 Administration Review (1 Feb. 1999)

When the vessel is issued an International Load Line Certificate, Passenger Ship Safety Certificate, Cargo Ship Safety Construction Certificate, International Certificate for Fitness for the Carriage of Liquefied Gas in Bulk, International Certificate for Fitness for the Carriage of Dangerous Chemicals in Bulk or International Oil Pollution Prevention Certificate by the flag Administration or its agent other than the Bureau, such Certificate will be accepted as evidence that the vessel has subdivision and stability in accordance with the criteria in the respective Convention.

Where the Administration undertakes the review of subdivision and stability and the Bureau is issuing the above certificate, the acceptance of subdivision and stability by the Administration will be required before the certificate is issued.

### 5.3 Bureau Review

In all other cases, the information and calculations for subdivision and stability are to be submitted to the Bureau for review. Where the intact stability criteria are not applicable to a particular vessel, the review will be in accordance with other recognized criteria acceptable to the Bureau.

## 7 Damage Control Plan for Dry Cargo Vessels

A plan showing clearly for each deck and hold and boundaries of the watertight compartments, the openings therein with the means of closure and position of any controls thereof, and the arrangements for the correction of any list due to flooding, is to be permanently exhibited or readily available on the navigation bridge. In addition, booklets containing the aforementioned information are to be made available to the officers of the vessel.

## 9 Onboard Computers for Stability Calculations (1 July 2005)

The use of onboard computers for stability calculations is not a requirement of class. However, if stability software is installed onboard vessels contracted on or after 1 July 2005, it should cover all stability requirements applicable to the vessel and is to be approved by the Bureau for compliance with the requirements of Appendix 3-3-A3, "Onboard Computers for Stability Calculations". The hardware is to be either approved in accordance with the recognized standards\*, or at least two computers are to be nominated and specifically provided with software capable of performing stability calculations for the vessel.

\* Note: A guideline on hardware approval is available from IACS Recommendation No. 48, 3.2 "Stand-alone Computer Hardware"



PART

# 3

CHAPTER **3 Subdivision and Stability**

APPENDIX **1 Intact Stability of Tankers During Liquid Transfer Operations**

## **1 General**

### **1.1 Note**

The following requirements as specified in 3-3-1/3.1 for tankers (i.e., vessels designed to carry liquid in bulk) are developed from MSC/Circ. 706 (MEPC/Circ. 304), which contains recommendations for existing oil tankers. The phenomenon of lolling is considered to be a safety issue for double hull tankers, as well as for other tankers having exceptionally wide cargo tanks (i.e., having cargo tank breadths greater than 60% of the vessel's maximum beam), which should be solved for every vulnerable tanker. The solution should not be limited only to tankers subject to MARPOL.

### **1.3 Operations to be Addressed (1 Feb. 1999)**

The Appendix applies to any tanker that is not subject to MARPOL Convention Annex I Regulation 25A. Alternatively, such tankers may comply with MARPOL Convention Annex I Regulation 25A.

## **3 (1999)**

Every tanker is to comply with the intact stability criteria specified in 3-3-A1/3.1 and 3-3-A1/3.3 for any operating draught reflecting actual, partial or full load conditions, including the intermediate stages of liquid transfer operations.

Liquid transfer operations include cargo loading and unloading, ballasting and deballasting, ballast water exchange and tank cleaning operations.

### **3.1**

In port, the initial metacentric height  $GM_o$  is not to be less than 0.15 m. Positive intact stability is to extend from the initial equilibrium position at which  $GM_o$  is calculated over a range of at least 20 degrees to port and to starboard.

### **3.3**

At sea, the intact stability criteria contained in paragraphs 3.1.2.1 to 3.1.2.4 of IMO Resolution A.749 (18), the Intact Stability Code, are applicable, or the criteria contained in the national requirements of the flag administration if the national stability requirements provide at least an equivalent degree of safety.

## 5 (1999)

For all loading conditions in port and at sea, including intermediate stages of liquid transfer operations, the initial metacentric height and the righting lever curve are to be corrected for the effect of free surfaces of liquids in tanks. Reference may be made to the Unified Interpretation LL61 Method of Correction for the Effect of Free Surface of Liquids in Tanks, set out by the International Association of Classification Societies.

## 7

The intact stability criteria specified in 3-3-A1/3 preferably is to be met by design of the vessel, i.e., the design should allow for maximum free surface effects in all cargo, ballast and consumables tanks during liquid transfer operations.

## 9

If the intact stability criteria specified in 3-3-A1/3 are not met through design of the vessel alone, the Master is to be provided with clear instructions covering the operational restrictions and methods necessary to ensure compliance with these criteria during liquid transfer operations. These instructions should be simple and concise, and:

### 9.1

In a language understood by the officer-in-charge of transfer operations;

### 9.3

Require no more than minimal mathematical calculations by the officer-in-charge;

### 9.5

Indicate the maximum number of cargo and ballast tanks which may be slack under any possible condition of liquid transfer;

### 9.7

Provide pre-planned sequences of cargo/ballast transfer operations, which indicate the cargo and ballast tanks which may be slack to satisfy the stability criteria under any specific condition of liquid transfer, including possible range of cargo densities. The slack tanks may vary during stages of the transfer operations and be any combination which satisfies the stability criteria;

### 9.9

Provide instructions for pre-planning other sequences of cargo/ballast transfer operations, including use of stability performance criteria in graphical or tabular form which enable comparisons of required and attained stability. These instructions for pre-planning other sequences, in relation to individual vessels, should take account of:

- i) The degree of criticality with respect to the number of tanks which can simultaneously have maximum free surface effects at any stage of liquid transfer operations;
- ii) The means provided to the officer-in-charge to monitor and assess the effects on stability and hull strength throughout the transfer operations;

- iii)* The need to give sufficient warning of an impending critical condition by reference to suitable margins (and the rate and direction of change) of the appropriate stability and hull strength parameters. If appropriate, the instructions should include safe procedures for suspending transfer operations until a suitable plan of remedial action has been evaluated.
- iv)* The use of on-line shipboard computer systems, where fitted, during all liquid transfer operations, processing cargo and ballast tank ullage data and cargo densities to continuously monitor the vessel's stability and hull strength and, when necessary, to provide effective warning of an impending critical situation, possibly automatic shut-down, and evaluation of possible remedial actions;

### **9.11**

Provide for corrective actions to be taken by the officer-in-charge in case of unexpected technical difficulties with the recommended pre-planned transfer operations and in case of emergency situations. A general reference to the vessel's shipboard oil pollution emergency plan may be included; and

### **9.13**

The instructions required above be prominently displayed:

- i)* In the approved trim and stability booklets;
- ii)* At the cargo/ballast transfer control station;
- iii)* In any computer software by which intact stability is monitored or calculations performed;
- iv)* In any computer software by which hull strength is monitored or calculations performed.

This Page Intentionally Left Blank

PART

# 3

CHAPTER **3 Subdivision and Stability**

APPENDIX **2 Subdivision and Damage Stability Requirements for Bulk Carriers**  
*(1 July 1998)*

## **1 General**

### **1.1 Note**

The following requirements, as specified in 3-3-1/3.3 for certain bulk carriers with 150 meters (492 feet) in length ( $L_f$ ) and above of single side skin construction intended to carry solid bulk cargoes with specific density of  $1.0 \text{ t/m}^3$  ( $62.4 \text{ lb/ft}^3$ ) and above, are developed based on the new Regulation XII/4 of SOLAS 1974, as amended, 'Damage Stability Requirements Applicable to Bulk Carriers' which will be implemented on 1 July 1999 for new bulk carriers. The application of the requirements from the Regulation is extended as a condition of classification for consistency with the new strength/structural requirements under flooded conditions specified in 5-3-A5a/1 (Longitudinal Strength), 5-3-A5b/1 (Corrugated Transverse Watertight Bulkheads) and 5-3-A5c/1 (Permissible Cargo Loads in Holds).

### **1.3 Applicability (2001)**

Single side skin bulk carriers of 150 m (492 ft) in length ( $L_f$ ) and greater, designed to carry solid bulk cargoes having a density of  $1.0 \text{ t/m}^3$  ( $62.4 \text{ lb/ft}^3$ ) and above are, when loaded to the summer load line, to be able to withstand flooding of any one cargo hold of single side skin construction in all loading conditions and remain afloat in a satisfactory condition of equilibrium, as specified in 3-3-A2/3.

## **3 Damage Stability Criteria**

The condition of equilibrium after flooding is to satisfy the condition of equilibrium laid down in Regulation 27 as per the 1988 Protocol to the International Convention on Load Lines, 1966, as amended.

The assumed flooding need only take into account flooding of the cargo hold space. The permeability of a loaded hold is to be assumed as 0.9 and the permeability of an empty hold is to be assumed as 0.95, unless permeability relevant to a particular cargo is assumed for the volume of a flooded hold occupied by cargo and permeability of 0.95 is assumed for the remaining empty volume of the hold.

## 5 Bulk Carriers with a Reduced Freeboard

Alternatively, bulk carriers which have been assigned a reduced freeboard in compliance with the provisions of paragraph (8) of the Regulation Equivalent to Regulation 27 of the International Convention on Load Lines, 1966, adopted by Resolution A.320(IX), as amended by Resolution A.514(13), may be considered as complying with 3-3-A2/1.3.

On bulk carriers which have been assigned a reduced freeboard in compliance with the provisions of Regulation 27(8) set out in Annex B of the Protocol of 1988 relating to the International Convention on Load Lines, 1966, the condition of equilibrium after flooding shall satisfy the relevant provisions of that Protocol.

PART

# 3

CHAPTER **3 Subdivision and Stability**

APPENDIX **3 Onboard Computers for Stability Calculations** *(1 July 2005)*

## **1 General**

### **1.1 Scope**

The scope of stability calculation software is to be in accordance with the stability information as approved by the flag Administration or the Bureau on behalf of the flag Administration. The software is at least to include all information and perform all calculations or checks as necessary to ensure compliance with the applicable stability requirements.

Approved stability software is not a substitute for the approved stability information, and is used as a supplement to the approved stability information to facilitate stability calculations.

### **1.3 Design**

The input/output information is to be easily comparable with approved stability information so as to avoid confusion and possible misinterpretation by the operator relative to the approved stability information.

An operation manual is to be provided for the onboard computer stability software.

The language in which the stability information is displayed and printed out as well as the operation manual is written is to be the same as used in the vessel's approved stability information. The primary language is to be English.

The onboard computer for stability calculations is vessel specific equipment and the results of the calculations are only applicable to the vessel for which it has been approved.

In case of modifications implying changes in the main data or internal arrangement of the vessel, the specific approval of any original stability calculation software is no longer valid. The software is to be modified accordingly and reapproved.

## **3 Calculation Systems**

This Appendix covers either system, a passive system that requires manual data entry or an active system, which replaces the manual with the automatic entry with sensors reading and entering the contents of tanks, etc., provided the active system is in the off-line operation mode. However, an integrated system, which controls or initiates actions based on the sensor-supplied inputs is not within the scope of this Appendix.

## 5 Types of Stability Software

Three types of calculations performed by stability software are acceptable depending upon a vessel's stability requirements:

- Type 1 Software calculating intact stability only (for vessels not required to meet a damage stability criterion)
- Type 2 Software calculating intact stability and checking damage stability on basis of a limit curve (for vessels applicable to SOLAS Part B-1 damage stability calculations, etc.) or previously approved loading conditions
- Type 3 Software calculating intact stability and damage stability by direct application of preprogrammed damage cases for each loading condition (for some tankers etc.)

## 7 Functional Requirements

### 7.1 Calculation Program

The calculation program is to present relevant parameters of each loading condition in order to assist the Master in his judgment on whether the vessel is loaded within the approval limits. The following parameters are to be presented for a given loading condition:

- Deadweight data
- Lightship data
- Trim
- Draft at the draft marks and perpendiculars
- Summary of loading condition displacement, VCG, LCG and, if applicable, TCG
- Downflooding angle and corresponding downflooding opening
- Compliance with stability criteria: Listing of all calculated stability criteria, the limit values, the obtained values and the conclusions (criteria fulfilled or not fulfilled)

### 7.3 Direct Damage Stability Calculations

If direct damage stability calculations are performed, the relevant damage cases according to the applicable rules are to be pre-defined for automatic check of a given loading condition.

### 7.5 Warning

A clear warning is to be given on screen and in hard copy printout if any of the loading limitations are not complied with.

### 7.7 Data Printout

The data are to be presented on screen and in hard copy printout in a clear unambiguous manner.

### 7.9 Date and Time

The date and time of a saved calculation are to be part of the screen display and hard copy printout.



## 7.11 Information of Program

Each hard copy printout is to include identification of the calculation program with version number.

## 7.13 Units

Units of measurement are to be clearly identified and used consistently within a loading calculation.

# 9 Acceptable Tolerances

Depending on the type and scope of programs, the acceptable tolerances are to be determined differently, according to 3-3-A3/9.1 or 3-3-A3/9.3. In general, deviation from these tolerances is not to be accepted unless a satisfactory explanation for the difference is submitted for review and the same is satisfactorily confirmed by the Bureau that there would be no adverse effect on the safety of the vessel.

*Examples of pre-programmed input data include the following:*

- Hydrostatic data: Displacement, LCB, LCF, VCB, KMt and MCT vs. draft
- Stability data: KN or MS values at appropriate heel/trim angles vs. displacement, stability limits.
- Compartment data: Volume, LCG, VCG, TCG and FSM/Grain heeling moments vs. level of the compartment's contents.

*Examples of output data include the following:*

- Hydrostatic data: Displacement, LCB, LCF, VCB, KMt and MCT versus draft, as well as actual drafts, trim.
- Stability data: FSC (free surface correction), GZ-values, KG, GM, KG/GM limits, allowable grain heeling moments, derived stability criteria (e.g., areas under the GZ curve), weather criteria.
- Compartment data: Calculated Volume, LCG, VCG, TCG and FSM/Grain heeling moments vs. level of the compartment's contents

The computational accuracy of the calculation program results is to be within the acceptable tolerances specified in 3-3-A3/9.1 or 3-3-A3/9.3, of the results using an independent program or the approved stability information with identical input.

## 9.1 Calculation Program of the Approved Stability Information

Programs which use only pre-programmed data from the approved stability information as the basis for stability calculations are to have zero tolerances for the printouts of input data.

Output data tolerances are to be close to zero. However, small differences associated with calculation rounding or abridged input data are acceptable. Additionally differences associated with the use of hydrostatic and stability data for trims that differ from those in the approved stability information are acceptable subject to review by the Bureau.

## 9.3 Independent Program for Assessment of Stability

Programs which use hull form models as their basis for stability calculations are to have tolerances for the printouts of basic calculated data established against either data from the approved stability information or data obtained using the approval authority's model. Acceptable tolerances shall be in accordance with 3-3-A3/Table 1.

**TABLE 1**  
**Acceptable Tolerances**

<i>Hull Form Dependent</i>	<i>Acceptable Tolerance <sup>(1)</sup></i>
Displacement	2%
Longitudinal center of buoyancy, from AP	1%/50 cm max
Vertical center of buoyancy	1%/5 cm max
Transverse center of buoyancy	0.5% of B/5 cm max
Longitudinal center of flotation, from AP	1%/50 cm max
Moment to trim 1 cm	2%
Transverse metacentric height	1%/5 cm max
Longitudinal metacentric height	1%/50cm max
Cross curves of stability	50 mm
<i>Compartment Dependent</i>	
	<i>Acceptable Tolerance <sup>(1)</sup></i>
Volume or deadweight	2%
Longitudinal center of gravity, from AP	1%/50 cm max
Vertical centre of gravity	1%/5 cm max
Transverse center of gravity	0.5% of B/5 cm max
Free surface moment	2%
Shifting moment	5%
Level of contents	2%
<i>Trim and Stability</i>	
	<i>Acceptable Tolerance <sup>(1)</sup></i>
Drafts (forward, aft, mean)	1%/5 cm max
GMt	1%/5 cm max
GZ values	1%/5 cm max
FS correction	2%
Downflooding angle	2°
Equilibrium angles	1°
Distance to unprotected openings or margin line from WL, if applicable	±5%/50 mm
Areas under righting arm curve	5% or 0.0012 mrad

Notes:

- 1 Deviation in % = [(base value – applicant’s value)/base value] × 100.
- 2 Where the “base value” may be from the approved stability information or the results of master computer using an independent program.

## 11 Approval Procedure

### 11.1 Conditions of Approval of the Onboard Computers for Stability Calculations

The onboard computer and software used for stability calculations are subject to approval, which is to include:

- Verification of type approval, if any,
- Verification that the data used is consistent with the current condition of the vessel (see 3-3-A3/11.5),

- Verification and approval of the test conditions, and
- Verification that the software is appropriate for the type of vessel and stability calculations required.

The satisfactory operation of the onboard computer(s) for stability calculations is to be verified by testing upon installation (see 3-3-A3/15). A copy of the approved test conditions and the operation manual for the computer/software are to be available onboard.

### 11.3 General Approval (optional)

Upon receipt of application for general approval of the calculation program, the Bureau may provide the applicant with test data consisting of two or more design data sets, each of which is to include a vessel's hull form data, compartmentation data, lightship characteristics and deadweight data, in sufficient detail to accurately define the vessel and its loading condition.

Acceptable hull form and compartmentation data may be in the form of surface coordinates for modeling the hull form and compartment boundaries (e.g., a table of offsets) or in the form of pre-calculated tabular data (e.g., hydrostatic tables, capacity tables) depending upon the form of data used by the software being submitted for approval. Alternatively, the general approval may be given based on at least two test vessels agreed upon between the applicant and the Bureau.

In general, the software is to be tested for two types of vessels for which approval is requested, with at least one design data set for each of the two types. Where approval is requested for only one type of vessel, a minimum of two data sets for different hull forms of that type of vessel are required to be tested.

For calculation software which is based on the input of hull form data, design data sets are to be provided for three types of vessels for which the software is to be approved, or a minimum of three data sets for different hull forms if approval is requested for only one type of vessel. Representative vessel types which require different design data sets due to their hull forms, typical arrangements, and nature of cargo include: tanker, bulk carrier, container carrier, and other dry cargo and passenger vessels.

The test data sets are to be used by the applicant to run the calculation program for the test vessels. The results obtained, together with the hydrostatic data and cross-curve data developed by the program, if appropriate are to be submitted to the Bureau for the assessment of the program's computational accuracy. The Bureau is to perform parallel calculations using the same data sets and a comparison of these results will be made against the applicant's submitted program's results.

### 11.5 Specific Approval

The Bureau is to verify the accuracy of the computational results and actual vessel data used by the calculation program for the particular vessel on which the program will be installed.

Upon receipt of application for data verification, the Bureau and the applicant are to agree on a minimum of four loading conditions, taken from the vessel's approved stability information, which are to be used as the test conditions.

For vessels carrying liquids in bulk, at least one of the conditions is to include partially filled tanks. For vessels carrying grain in bulk, one of the grain loading conditions is to include a partially filled grain compartment. Within the test conditions each compartment is to be loaded at least once. The test conditions normally are to cover the range of load drafts from the deepest envisaged loaded condition to the light ballast condition and are to include at least one departure and one arrival condition.

The Bureau is to verify that the following data, submitted by the applicant, is consistent with arrangements and most recently approved lightship characteristics of the vessel according to current plans and documentation on file with the Bureau, subject to possible further verification onboard:

- Identification of the calculation program including version number.
- Main dimensions, hydrostatic particulars and, if applicable, the vessel profile.
- The position of the forward and after perpendiculars, and if appropriate, the calculation method to derive the forward and after drafts at the actual position of the vessel's draft marks.
- Vessel lightweight and center of gravity derived from the most recently approved inclining experiment or light weight check.
- Lines plan, offset tables or other suitable presentation of hull form data if necessary for the Bureau to model the vessel.
- Compartment definitions, including frame spacing, and centers of volume, together with capacity tables (sounding/ullage tables), free surface corrections, if appropriate
- Cargo and Consumables distribution for each loading condition.

Verification by the Bureau does not absolve the applicant and shipowner of responsibility for ensuring that the information programmed into the onboard computer software is consistent with the current condition of the vessel.

## 13 Operation Manual

A simple and straightforward operation manual is to be provided, containing descriptions and instructions, as appropriate, for at least the following:

- Installation
- Function keys
- Menu displays
- Input and output data
- Required minimum hardware to operate the software
- Use of the test loading conditions
- Computer-guided dialogue steps
- List of warnings

## 15 Installation Testing

To ensure correct working of the computer after the final or updated software has been installed, it is the responsibility of the vessel's master to have test calculations carried out according to the following pattern in the presence of the Surveyor:

- From the approved test conditions at least one load case (other than lightship) is to be calculated.  
*Note:* Actual loading condition results are not suitable for checking the correct working of the computer.
- Normally, the test conditions are permanently stored in the computer.

Steps to be performed:

- Retrieve the test load case and start a calculation run; compare the stability results with those in the documentation.
- Change several items of deadweight (tank weights and the cargo weight) sufficiently to change the draft or displacement by at least 10%. The results are to be reviewed to ensure that they differ in a logical way from those of the approved test condition.
- Revise the above modified load condition to restore the initial test condition and compare the results. The relevant input and output data of the approved test condition are to be replicated.
- Alternatively, one or more test conditions shall be selected and the test calculation performed by entering all deadweight data for each selected test condition into the program as if it were a proposed loading. The results shall be verified as identical to the results in the approved copy of the test conditions.

## 17 Periodical Testing

It is the responsibility of the vessel's master to check the accuracy of the onboard computer for stability calculations at each Annual Survey by applying at least one approved test condition.

If the Surveyor is not present for the computer check, a copy of the test condition results obtained by the computer check is to be retained onboard as documentation of satisfactory testing for the Surveyor's verification.

At each Special Periodical Survey, this checking for all approved test loading conditions is to be done in presence of the surveyor.

The testing procedure is to be carried out in accordance with 3-3-A3/15.

## 19 Other Requirements

The following features are to be provided to the software:

- Protection against unintentional or unauthorized modification of programs and data is to be provided.
- The program is to monitor operations and activate an alarm when the program is incorrectly or abnormally used.
- The program and any data stored in the system are to be protected from corruption by loss of power.
- Error messages with regard to limitations such as filling a compartment beyond capacity, or exceeding the assigned load line, etc. are to be included.

This Page Intentionally Left Blank

PART

# 3

CHAPTER

## 4 Fire Safety Measures

### CONTENTS

---

<b>SECTION 1</b>	<b>Structural Fire Protection.....</b>	<b>251</b>
1	General .....	251
	1.1 SOLAS Application.....	251
	1.3 Regulation .....	251
	1.5 Definitions .....	251
	1.7 Materials Containing Asbestos.....	251
3	Passenger Vessels .....	251
5	Cargo Vessel .....	251
	5.1 All Vessels .....	251
	5.3 Tankers .....	252
7	Review Procedures.....	252
	7.1 Administration Review.....	252
	7.3 Bureau Review.....	252

This Page Intentionally Left Blank



PART

# 3

CHAPTER **4 Fire Safety Measures**

SECTION **1 Structural Fire Protection**

## **1 General**

### **1.1 SOLAS Application**

For classification purposes, the fire safety measures contained in the International Convention for the Safety of Life at Sea, 1974 (1974 SOLAS) as amended, are applicable to vessels of type, size and service coming under that Convention.

This Chapter does not relax the requirements in other Chapters of these Rules.

### **1.3 Regulation**

Regulation means the regulation contained in 1974 SOLAS, as amended. An abbreviated notation is used, e.g., Regulation II-2/5.2 means Regulation 5.2 of Chapter II-2.

### **1.5 Definitions**

See Regulation II-2/3.

### **1.7 Materials Containing Asbestos (2005)**

See Regulation II-1/3-5.

## **3 Passenger Vessels**

For Passenger vessels, the requirements in the ABS *Guide for Building and Classing Passenger Vessels* are applicable.

## **5 Cargo Vessel**

### **5.1 All Vessels**

For all cargo vessels as defined in Regulation 3.7, the relevant requirements in Part B: Regulation 4, 5, 6; Part C: Regulations 7, 8, 9, 10, 11; Part D: Regulation 13; and Part G: Regulations 19 and 20, Chapter II-2 of 1974 SOLAS, as amended, are applicable.

## 5.3 Tankers

For tankers as defined in Regulations 3.48, Chapter II-2 of 1974 SOLAS, as amended, the following requirements are additional to 3-4-1/5.1.

### 5.3.1 Low Flash Point Cargoes

For tankers intended for the carriage of cargoes having a flash point of 60°C (140°F) or less, the relevant requirements in Part A: Regulation 1; Part B: Regulation 4; Part C: Regulations 9, 10, 11; and Part E: Regulations 16, Chapter II-2 of 1974 SOLAS, as amended, are applicable. Furthermore, the requirements of Chapters 2, 14 and 15 of the Fire Safety Systems Code are also applicable.

### 5.3.2 High Flash Point Cargoes

For tankers intended for the carriage of cargoes having a flash point above 60°C (140°F), the requirements in 3-4-1/5.1 are applicable, except that in lieu of the fixed fire extinguishing system required by Regulation II-2/10.7.1.3 they are to be fitted with a fixed deck foam system which is to comply with Chapter 14 of the Fire Safety Systems Code.

## 7 Review Procedures

### 7.1 Administration Review

When the vessel is issued a Passenger Ship Safety Certificate, Cargo Ship Safety Equipment Certificate or Cargo Ship Safety Construction Certificate by the flag Administration or its agent other than the Bureau, such Certificate will be accepted as evidence that the vessel is in accordance with the applicable criteria in 1974 SOLAS as amended.

Where the Administration undertakes any part of the review and the Bureau is issuing the above certificate, the acceptance by the Administration will be required before the certificate is issued.

Compliance with the Rule requirements in addition to those in 1974 SOLAS, as amended, is to be verified by the Bureau.

### 7.3 Bureau Review

In all other cases, the required information and plan are to be submitted to the Bureau for review.

**CONTENTS**

<b>SECTION 1</b>	<b>Anchoring, Mooring and Towing Equipment .....</b>	<b>255</b>
1	General .....	255
3	Equipment Mass and Size .....	255
5	Tests .....	256
7	Anchor Types .....	257
9	Hawsers and Towlines .....	257
9.1	All Vessels .....	257
11	Windlass Support Structure and Cable Stopper .....	257
11.1	General .....	257
11.3	Support Structure .....	258
11.5	Trial .....	259
13	Hawse Pipes .....	261
15	Bollard, Fairlead and Chocks .....	261
15.1	General .....	261
15.3	Deck Fittings .....	261
15.5	Safe Working Load (SWL) .....	261
15.7	Emergency Towing Arrangements .....	261
17	Chafing Chain for Emergency Towing Arrangements .....	261
17.1	Scope .....	261
17.3	Qualification of Manufacturers .....	261
17.5	Materials .....	261
17.7	Design, Manufacture, Testing and Certification of Chafing Chain .....	262
TABLE 1	Equipment for Self-propelled Ocean-going Vessels .....	264
TABLE 2	Towline and Hawsers for Self-propelled Ocean-going Vessels .....	268
FIGURE 1	Effective Heights of Deck Houses .....	256
FIGURE 2	Direction of Forces and Weight .....	260
FIGURE 3	Sign Convention .....	260
FIGURE 4	Typical Outboard Chafing Chain End .....	263

This Page Intentionally Left Blank

PART

**3**

CHAPTER **5 Equipment**

SECTION **1 Anchoring, Mooring and Towing Equipment**

**1 General**

All vessels are to have a complete equipment of anchors and chains. The letter **ⓔ** placed after the symbols of classification in the *Record*, thus: **⊗A1 ⓔ**, will signify that the equipment of the vessel is in compliance with the requirements of the Rules, or with requirements corresponding to the service limitation noted in the vessel's classification, which have been specially approved for the particular service. The mass per anchor of bower anchors, given in 3-5-1/Table 1, is for anchors of equal mass. The mass of individual anchors may vary 7% plus or minus from the tabular mass, provided that the combined mass of all anchors is not less than that required for anchors of equal mass. The total length of chain required to be carried onboard, as given in 3-5-1/Table 1, is to be reasonably divided between the two bower anchors.

Cables which are intended to form part of the equipment are not to be used as check chains when the vessel is launched. The inboard ends of the cables of the bower anchors are to be secured by efficient means. Two bower anchors and their cables are to be connected and positioned, ready for use. Where three anchors are given in 3-5-1/Table 1, the third anchor is intended as a spare bower anchor and is listed for guidance only; it is not required as a condition of classification. Means are to be provided for stopping each cable as it is paid out, and the windlass should be capable of heaving in either cable. Suitable arrangements are to be provided for securing the anchors and stowing the cables.

**3 Equipment Mass and Size (2001)**

The requirements herein are intended for temporary mooring of a vessel within a harbor or other areas of sheltered water. The "Equipment Number" equation is based on 2.5 m/s (8.2 ft/s) current, 25 m/s (49 knots) wind and a scope of 6 through 10, the scope being the ratio of length of chain paid out to the water depth. Anchors and chains are to be in accordance with 3-5-1/Table 1 and the numbers, mass and sizes of these are to be regulated by the equipment number (*EN*) obtained from the following equation:

$$\text{Equipment Number} = k\Delta^{2/3} + mBh + nA$$

where

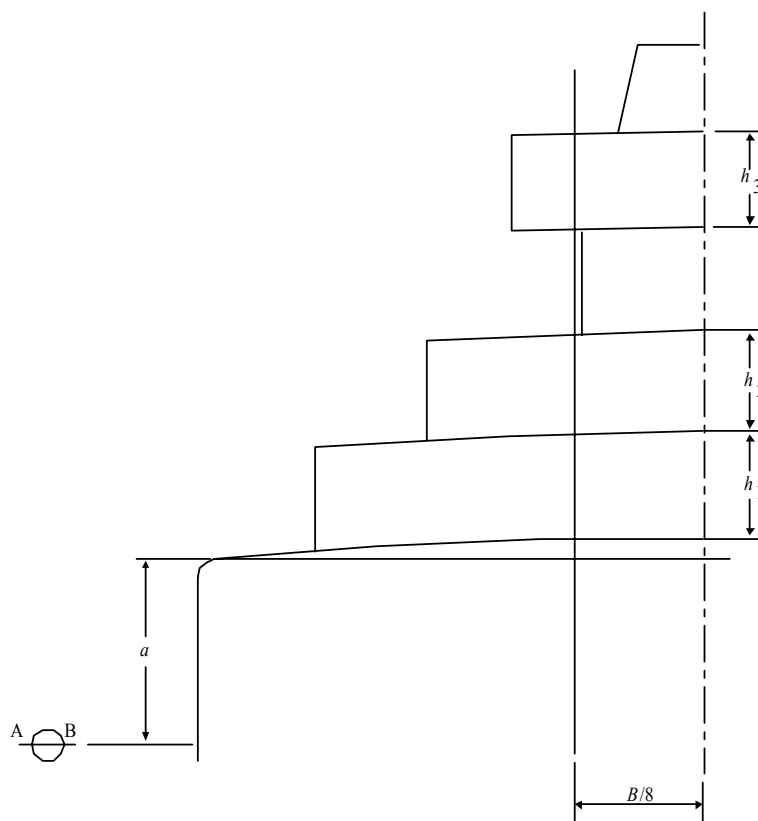
$$k = 1.0 \text{ (1.0, 1.012)}$$

$$m = 2 \text{ (2, 0.186)}$$

$$n = 0.1 \text{ (0.1, 0.00929)}$$

- $\Delta$  = molded displacement, as defined in 3-1-1/11.1
- $B$  = molded breadth, as defined in 3-1-1/5, in m (ft)
- $h$  =  $a + h_1 + h_2 + h_3 + \dots$ , as shown in 3-5-1/Figure 1. In the calculation of  $h$ , sheer, camber and trim may be neglected
- $a$  = freeboard, in m (ft), from the summer load waterline amidships
- $h_1, h_2, h_3 \dots$  = height, in m (ft), on the centerline of each tier of houses having a breadth greater than  $B/4$
- $A$  = profile area, in  $m^2$  ( $ft^2$ ), of the hull, superstructure and houses above the summer load waterline which are within the Rule length. Superstructures or deck houses having a breadth at any point no greater than  $0.25B$  may be excluded. Screens and bulwarks more than 1.5 m (4.9 ft) in height are to be regarded as parts of houses when calculating  $h$  and  $A$

**FIGURE 1**  
**Effective Heights of Deck Houses**



## 5 Tests

Tests are to be in accordance with the requirements of Part 2, Chapter 2 for the respective sizes of anchors and chains. See Section 2-2-1 and Section 2-2-2.

## 7 Anchor Types

Anchors are to be of the stockless type. The mass of the head of a stockless anchor, including pins and fittings, is not to be less than three-fifths of the total mass of the anchor. Where specifically requested by the Owners, the Bureau is prepared to give consideration to the use of special types of anchors and where these are of proven superior holding ability, consideration may also be given to some reduction in the mass, up to a maximum of 25% from the mass specified in 3-5-1/Table 1. In such cases, the notation **RW** will be made in the *Record*.

## 9 Hawsers and Towlines

### 9.1 All Vessels (1995)

Except as indicated in 3-5-1/15.7, hawsers and towlines are not required as a condition of classification. The hawsers and towlines listed in 3-5-1/Table 2 are intended as a guide. Where the tabular breaking strength exceeds 490 kN (50,000 kgf, 110,200 lbf), the breaking strength and the number of individual hawsers given in the Table may be modified, provided their product is not less than that of the breaking strength and the number of hawsers given in the Table. For vessels having an *A/EN* ratio greater than 0.9 for SI or MKS units (9.7 for US units), the number of hawsers given in 3-5-1/Table 2 is to be increased by the number given below.

<i>A/EN Ratio</i>		<i>Increase number of hawsers by</i>
<i>SI Units MKS Units</i>	<i>U.S.Units</i>	
Above 0.9 up to 1.1	above 9.7 up to 11.8	1
Above 1.1 up to 1.2	above 11.8 up to 12.9	2
above 1.2	above 12.9	3

where

*A* = defined in 3-5-1/3

*EN* = determined by the equation in 3-5-1/3

## 11 Windlass Support Structure and Cable Stopper

### 11.1 General (2004)

Construction and installation of all windlasses used for anchoring are to be carried out in accordance with 4-1-1/5 and Section 4-5-1. Where fitted, an independent cable stopper and its components are to be adequate for the load imposed. The arrangements and details of the cable stopper are to be submitted for review.

The windlass supporting structures are to meet the requirements in 3-5-1/11.3. Where the mooring winch is integral with the windlass, it is to be considered as a part of the windlass for the purpose of said paragraph.

### 11.3 Support Structure (2004)

The windlass is to be bolted down to a substantial foundation, which is to meet the following load cases and associated criteria.

#### 11.3.1 Operating Loads

*11.3.1(a) Load on Windlass Support Structure (2006).* The following load is to be applied in the direction of the chain.

With cable stopper **not attached to windlass**: 45% of B.S.

**With cable stopper attached to windlass**: 80% of B.S.

Without cable stopper: 80% of B.S.

B.S. = minimum breaking strength of the chain, as indicated in 2-2-2/Tables 2 and 3 of the *Rules for Materials and Welding – Part 2*.

*11.3.1(b) Load on Cable Stopper and Support Structure (2006).* A load of 80% of B.S. is to be applied in the direction of the chain.

*11.3.1(c) Allowable Stress (2006).* The stresses in the structures supporting the windlass and cable stopper are not to exceed the yield point.

#### 11.3.2 Sea Loads

*11.3.2(a) Pressures.* The following pressures and associated areas are to be applied (see 3-5-1/Figure 2):

- 200 kN/m<sup>2</sup> (20.4 tf/m<sup>2</sup>, 4178 lbf/ft<sup>2</sup>) normal to the shaft axis and away from the forward perpendicular, over the projected area in this direction,
- 150 kN/m<sup>2</sup> (15.3 tf/m<sup>2</sup>, 3133 lbf/ft<sup>2</sup>) parallel to the shaft axis and acting both inboard and outboard separately, over the multiple of  $f$  times the projected area in this direction,

where  $f$  is defined as:

$$f = 1 + B/H, f \text{ need not be taken as greater than } 2.5$$

$$B = \text{width of windlass measured parallel to the shaft axis}$$

$$H = \text{overall height of windlass.}$$

*11.3.2(b) Forces.* Forces in the bolts, chocks and stoppers securing the windlass to the deck are to be calculated. The windlass is supported by  $N$  groups of bolts, each containing one or more bolts, see 3-5-1/Figure 2.

*i) Axial Forces.* The aggregate axial force  $R_i$  in respective group of bolts (or bolt)  $i$ , positive in tension, may be calculated from the following equations:

$$R_{xi} = P_x h x_i A_i / I_x$$

$$R_{yi} = P_y h y_i A_i / I_y$$

and

$$R_i = R_{xi} + R_{yi} - R_{si}$$

where

$$P_x = \text{force, kN (tf, lbf), acting normal to the shaft axis}$$

$$P_y = \text{force, kN (tf, lbf), acting parallel to the shaft axis, either inboard or outboard, whichever gives the greater force in bolt group } i$$



- $h$  = shaft height above the windlass mounting, cm (in.)
- $x_i, y_i$  =  $x$  and  $y$  coordinates of bolt group  $i$  from the centroid of all  $N$  bolt groups, positive in the direction opposite to that of the applied force, cm (in.)
- $A_i$  = cross-sectional area of all bolts in group  $i$ , cm<sup>2</sup> (in<sup>2</sup>)
- $I_x$  =  $A_i x_i^2$  for  $N$  bolt groups
- $I_y$  =  $A_i y_i^2$  for  $N$  bolt groups
- $R_{si}$  = static reaction at bolt group  $i$ , due to weight of windlass.

- ii) *Shear forces.* Aggregated shear forces  $F_{xi}$ ,  $F_{yi}$  applied to the respective bolt group  $i$  of bolts, and the resultant combined force  $F_i$  may be calculated from:

$$F_{xi} = (P_x - \alpha g M) / N$$

$$F_{yi} = (P_y - \alpha g M) / N$$

and

$$F_i = (F_{xi}^2 + F_{yi}^2)^{0.5}$$

where:

- $\alpha$  = coefficient of friction (0.5)
- $M$  = mass of windlass, in tonnes (Ltons)
- $g$  = gravity: 9.81 m/sec<sup>2</sup> (32.2 ft/sec<sup>2</sup>)
- $N$  = number of groups of bolts

The axial tensile/compressive and lateral forces from the above equations are also to be considered in the design of the supporting structure.

11.3.2(c) *Stresses in Bolts.* Tensile axial stresses in the individual bolts in each group of bolts  $i$  are to be calculated. The horizontal forces  $F_{xi}$  and  $F_{yi}$  are normally to be reacted by shear chocks. Where “fitted” bolts are designed to support these shear forces in one or both directions, the von Mises equivalent stresses in the individual “fitted” bolts are to be calculated and compared to the stress under proof load. Where pourable resins are incorporated in the holding down arrangements, due account is to be taken in the calculations.

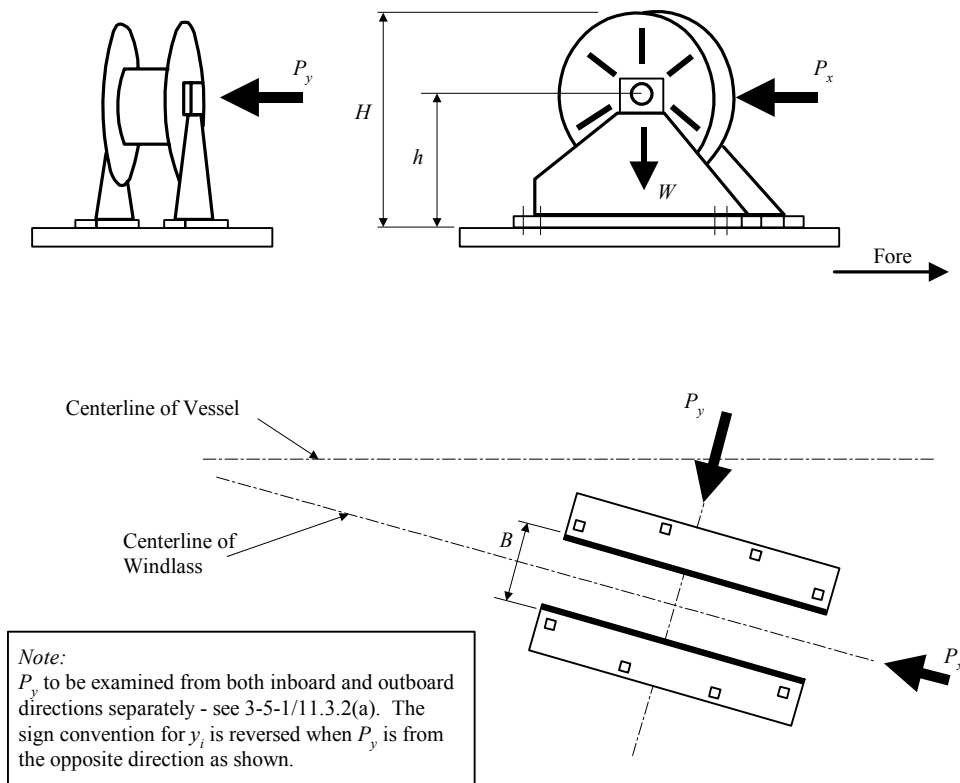
11.3.2(d) *Allowable Stress*

- i) *Bolts.* The safety factor against bolt proof strength is to be not less than 2.0.
- ii) *Supporting Structures.* The stresses in the above deck framing and the hull structure supporting the windlass are not to exceed the following values.
- Bending Stress 85% of the yield strength of the material
  - Shearing Stress 60% of the yield strength of the material

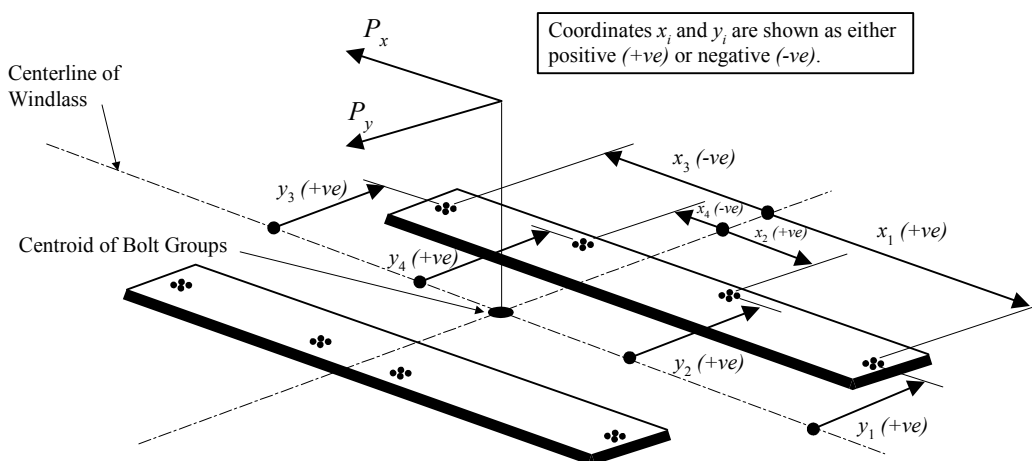
## 11.5 Trial

See 3-7-2/1.

**FIGURE 2**  
**Direction of Forces and Weight (2004)**



**FIGURE 3**  
**Sign Convention (2004)**



## 13 Hawse Pipes

Hawse pipes are to be of ample size and strength. They are to have full rounded flanges and the least possible lead, in order to minimize the nip on the cables. They are to be securely attached to thick doubling or insert plates by continuous welds the size of which are to be in accordance with Section 3-2-19 for the plating thickness and type of joint selected. When in position, they are to be thoroughly tested for watertightness by means of a hose in which the water pressure is not to be less than 2.06 bar (2.1 kgf/cm<sup>2</sup>, 30 psi). Hawse pipes for stockless anchors are to provide ample clearances. The anchors are to be shipped and unshipped so that the Surveyor may be satisfied that there is no risk of the anchor jamming in the hawse pipe. Care is to be taken to ensure a fair lead for the chain from the windlass to the hawse pipes and to the chain pipes.

## 15 Bollard, Fairlead and Chocks (1 October 2005)

### 15.1 General <No Text>

### 15.3 Deck Fittings <No Text>

### 15.5 Safe Working Load (SWL) <No Text>

### 15.7 Emergency Towing Arrangements (1 January 1996)

Tankers of 20,000 tonnes deadweight and above, including oil tankers, chemical tankers and gas carriers, are to be fitted with an emergency towing arrangement at both ends complying with Maritime Safety Committee Resolution MSC 35(63). Written approval by the flag Administration of the emergency towing arrangements will be accepted as evidence of compliance with this paragraph.

## 17 Chafing Chain for Emergency Towing Arrangements (2005)

### 17.1 Scope

These requirements apply to the chafing chain for chafing gear of two types of Emergency Towing Arrangement (ETA), those with a specified safe working load (SWL) of 1000 kN (ETA1000) and those with a specified safe working load of 2000 kN (ETA2000). Chafing chains other than those specified can be used subject to special agreement with the Bureau.

### 17.3 Qualification of Manufacturers

Chafing chain is to be manufactured by works approved by the Bureau, in accordance with 2-2-2/7.1 or in accordance with the *ABS Guide for Certification of Offshore Mooring Chain*.

### 17.5 Materials

Materials used for the manufacture of chafing chain are to meet the requirements of 2-2-2/7.11 or in accordance with the *ABS Guide for Certification of Offshore Mooring Chain*.

## 17.7 Design, Manufacture, Testing and Certification of Chafing Chain

### 17.7.1

Chafing chain is to be designed, manufactured, tested and certified in accordance with the requirements of Section 2-2-2 or in accordance with the *ABS Guide for Certification of Offshore Mooring Chain*.

### 17.7.2

The common link is to be of stud link type grade 2a, 2b or 3a, 3b Anchor Chain, or grade RQ3, RQ3S, RQ4 Mooring Chain.

### 17.7.3

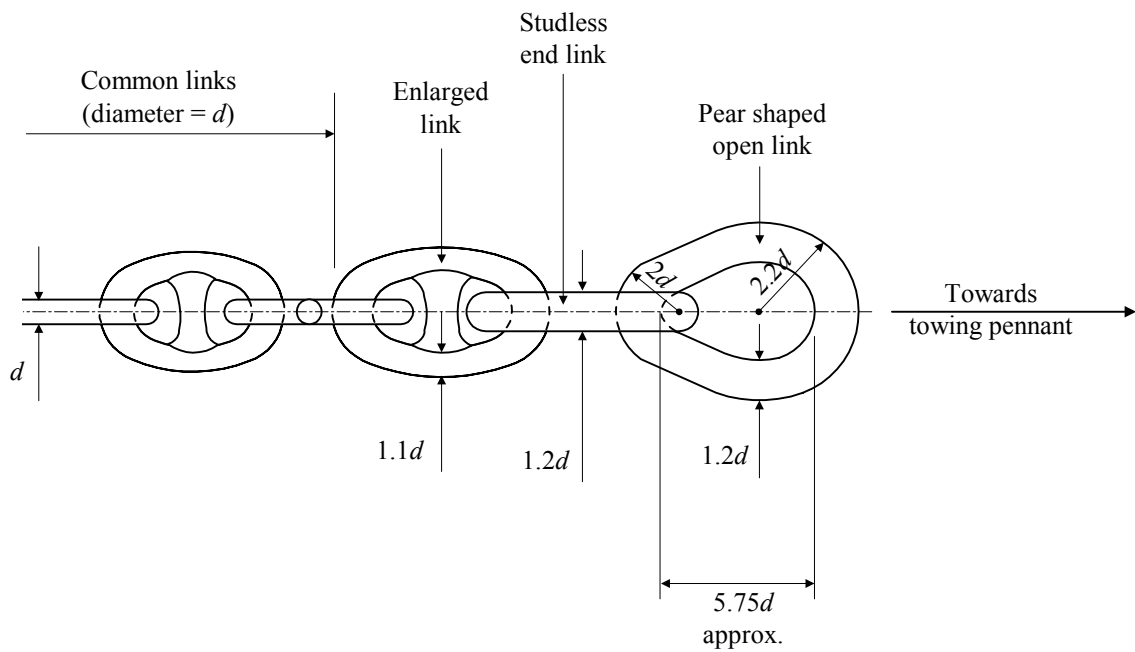
The arrangement at the end connected to the strongpoint and the dimensions of the chafing chain are determined by the type of ETA. The other end of the chafing chain is to be fitted with a pear-shaped open link allowing connection to a shackle corresponding to the type of ETA and chain cable grade. A typical arrangement of this chain end is shown in 3-5-1/Figure 4.

### 17.7.4

The chafing chain is to be able to withstand a breaking load not less than twice the SWL. For each type of ETA, the nominal diameter of common link for chafing chains is to comply with the value indicated below.

<i>Type of ETA</i>	<i>Nominal Diameter of Common Link, d, min.</i>	
	<i>Grade 2</i>	<i>Grade 3</i>
ETA1000	62 mm	52 mm
ETA2000	90 mm	76 mm

**FIGURE 4**  
**Typical Outboard Chafing Chain End (2005)**



**TABLE 1**  
**Equipment for Self-propelled Ocean-going Vessels**

SI, MKS Units

Equipment Numeral	Equipment Number <sup>•</sup>	Stockless Bower Anchors		Chain Cable Stud Link Bower Chain			
		Number	Mass per Anchor, kg	Length, m	Diameter		
					Normal- Strength Steel (Grade 1), mm	High- Strength Steel (Grade 2), mm	Extra High- Strength Steel (Grade 3), mm
U6	150	2	480	275	22	19	
U7	175	2	570	302.5	24	20.5	
U8	205	3	660	302.5	26	22	20.5
U9	240	3	780	330	28	24	22
U10	280	3	900	357.5	30	26	24
U11	320	3	1020	357.5	32	28	24
U12	360	3	1140	385	34	30	26
U13	400	3	1290	385	36	32	28
U14	450	3	1440	412.5	38	34	30
U15	500	3	1590	412.5	40	34	30
U16	550	3	1740	440	42	36	32
U17	600	3	1920	440	44	38	34
U18	660	3	2100	440	46	40	36
U19	720	3	2280	467.5	48	42	36
U20	780	3	2460	467.5	50	44	38
U21	840	3	2640	467.5	52	46	40
U22	910	3	2850	495	54	48	42
U23	980	3	3060	495	56	50	44
U24	1060	3	3300	495	58	50	46
U25	1140	3	3540	522.5	60	52	46
U26	1220	3	3780	522.5	62	54	48
U27	1300	3	4050	522.5	64	56	50
U28	1390	3	4320	550	66	58	50
U29	1480	3	4590	550	68	60	52
U30	1570	3	4890	550	70	62	54
U31	1670	3	5250	577.5	73	64	56
U32	1790	3	5610	577.5	76	66	58
U33	1930	3	6000	577.5	78	68	60
U34	2080	3	6450	605	81	70	62
U35	2230	3	6900	605	84	73	64
U36	2380	3	7350	605	87	76	66
U37	2530	3	7800	632.5	90	78	68
U38	2700	3	8300	632.5	92	81	70
U39	2870	3	8700	632.5	95	84	73
U40	3040	3	9300	660	97	84	76

**TABLE 1 (continued)**  
**Equipment for Self-propelled Ocean-going Vessels**

SI, MKS Units

Equipment Numeral	Equipment Number <sup>•</sup>	Stockless Bower Anchors		Chain Cable Stud Link Bower Chain			
		Number	Mass per Anchor, kg	Length, m	Diameter		
					Normal- Strength Steel (Grade 1), mm	High- Strength Steel (Grade 2), mm	Extra High- Strength Steel (Grade 3), mm
U41	3210	3	9900	660	100	87	78
U42	3400	3	10500	660	102	90	78
U43	3600	3	11100	687.5	105	92	81
U44	3800	3	11700	687.5	107	95	84
U45	4000	3	12300	687.5	111	97	87
U46	4200	3	12900	715	114	100	87
U47	4400	3	13500	715	117	102	90
U48	4600	3	14100	715	120	105	92
U49	4800	3	14700	742.5	122	107	95
U50	5000	3	15400	742.5	124	111	97
U51	5200	3	16100	742.5	127	111	97
U52	5500	3	16900	742.5	130	114	100
U53	5800	3	17800	742.5	132	117	102
U54	6100	3	18800	742.5		120	107
U55	6500	3	20000	770		124	111
U56	6900	3	21500	770		127	114
U57	7400	3	23000	770		132	117
U58	7900	3	24500	770		137	122
U59	8400	3	26000	770		142	127
U60	8900	3	27500	770		147	132
U61	9400	3	29000	770		152	132
U62	10000	3	31000	770			137
U63	10700	3	33000	770			142
U64	11500	3	35500	770			147
U65	12400	3	38500	770			152
U66	13400	3	42000	770			157
U67	14600	3	46000	770			162

• For intermediate values of equipment number, use equipment complement in sizes and weights given for the lower equipment number in the table.

**TABLE 1**  
**Equipment for Self-propelled Ocean-going Vessels**

US Units

Equipment Numeral	Equipment Number <sup>•</sup>	Stockless Bower Anchors		Chain Cable Stud Link Bower Chain			
		Number	Mass per Anchor, pounds	Length, fathoms	Diameter		
					Normal-Strength Steel (Grade 1), inches	High-Strength Steel (Grade 2), inches	Extra High-Strength Steel (Grade 3), inches
U6	150	2	1060	150	7/8	3/4	
U7	175	2	1255	165	15/16	13/16	
U8	205	3	1455	165	1	7/8	13/16
U9	240	3	1720	180	1 1/8	15/16	7/8
U10	280	3	1985	195	1 3/16	1	15/16
U11	320	3	2250	195	1 1/4	1 1/8	5/16
U12	360	3	2510	210	1 5/16	1 3/16	1
U13	400	3	2840	210	1 7/16	1 1/4	1 1/8
U14	450	3	3170	225	1 1/2	1 5/16	1 3/16
U15	500	3	3500	225	1 9/16	1 5/16	1 3/16
U16	550	3	3830	240	1 5/8	1 7/16	1 1/4
U17	600	3	4230	240	1 3/4	1 1/2	1 5/16
U18	660	3	4630	240	1 13/16	1 9/16	1 7/16
U19	720	3	5020	255	1 7/8	1 5/8	1 7/16
U20	780	3	5420	255	2	1 3/4	1 1/2
U21	840	3	5820	255	2 1/16	1 13/16	1 9/16
U22	910	3	6280	270	2 1/8	1 7/8	1 5/8
U23	980	3	6740	270	2 3/16	1 15/16	1 3/4
U24	1060	3	7270	270	2 5/16	2	1 13/16
U25	1140	3	7800	285	2 3/8	2 1/16	1 13/16
U26	1220	3	8330	285	2 7/16	2 1/8	1 7/8
U27	1300	3	8930	285	2 1/2	2 3/16	2
U28	1390	3	9520	300	2 5/8	2 5/16	2
U29	1480	3	10120	300	2 11/16	2 3/8	2 1/16
U30	1570	3	10800	300	2 3/4	2 7/16	2 1/8
U31	1670	3	11600	315	2 7/8	2 1/2	2 3/16
U32	1790	3	12400	315	3	2 5/8	2 5/16
U33	1930	3	13200	315	3 1/16	2 11/16	2 3/8
U34	2080	3	14200	330	3 3/16	2 3/4	2 7/16
U35	2230	3	15200	330	3 5/16	2 7/8	2 1/2
U36	2380	3	16200	330	3 7/16	3	2 5/8
U37	2530	3	17200	345	3 9/16	3 1/16	2 11/16
U38	2700	3	18300	345	3 5/8	3 3/16	2 3/4
U39	2870	3	19200	345	3 3/4	3 5/16	2 7/8
U40	3040	3	20500	360	3 7/8	3 5/16	3
U41	3210	3	21800	360	3 15/16	3 7/16	3 1/16
U42	3400	3	23100	360	4	3 9/16	3 1/16



**TABLE 1 (continued)**  
**Equipment for Self-propelled Ocean-going Vessels**

US Units

Equipment Numeral	Equipment Number <sup>•</sup>	Stockless Bower Anchors		Chain Cable Stud Link Bower Chain			
		Number	Mass per Anchor, pounds	Length, fathoms	Diameter		
					Normal-Strength Steel (Grade 1), inches	High-Strength Steel (Grade 2), inches	Extra High-Strength Steel (Grade 3), inches
U43	3600	3	24500	375	4 1/8	3 5/8	3 3/16
U44	3800	3	25800	375	4 1/4	3 3/4	3 5/16
U45	4000	3	27100	375	4 3/8	3 7/8	3 7/16
U46	4200	3	28400	390	4 1/2	3 15/16	3 7/16
U47	4400	3	29800	390	4 5/8	4	3 9/16
U48	4600	3	31100	390	4 3/4	4 1/8	3 5/8
U49	4800	3	32400	405	4 3/4	4 1/4	3 3/4
U50	5000	3	33900	405	4 7/8	4 3/8	3 7/8
U51	5200	3	35500	405	5	4 3/8	3 7/8
U52	5500	3	37200	405	5 1/8	4 1/2	3 15/16
U53	5800	3	39200	405	5 1/8	4 5/8	4
U54	6100	3	41400	405		4 3/4	4 1/4
U55	6500	3	44000	420		4 7/8	4 3/8
U56	6900	3	47400	420		5	4 1/2
U57	7400	3	50700	420		5 1/8	4 5/8
U58	7900	3	54000	420		5 3/8	4 3/4
U59	8400	3	57300	420		5 5/8	5
U60	8900	3	60600	420		5 3/4	5 1/8
U61	9400	3	63900	420		6	5 1/8
U62	10000	3	68000	420			5 3/8
U63	10700	3	72500	420			5 5/8
U64	11500	3	78000	420			5 3/4
U65	12400	3	85000	420			6
U66	13400	3	92500	420			6 1/8
U67	14600	3	101500	420			6 3/8

• For intermediate values of equipment number, use equipment complement in sizes and weights given for the lower equipment number in the table.

**TABLE 2**  
**Towline and Hawsers for Self-propelled Ocean-going Vessels**

SI & MKS Units

Equipment Numeral	Equipment Number <sup>•</sup>	Towline Wire or Rope			Hawsers			
		Length, m	Breaking Strength,		Number	Length of Each, m	Breaking Strength,	
kN	kgf		kN	kgf				
U6	150	180	98.0	10000	3	120	54.0	5500
U7	175	180	112.0	11400	3	120	59.0	6000
U8	205	180	129.0	13200	4	120	64.0	6500
U9	240	180	150.0	15300	4	120	69.0	7000
U10	280	180	174.0	17700	4	140	74.0	7500
U11	320	180	207.0	21100	4	140	78.0	8000
U12	360	180	224.0	22800	4	140	88.0	9000
U13	400	180	250.0	25500	4	140	98.0	10000
U14	450	180	277.0	28200	4	140	108.0	11000
U15	500	190	306.0	31200	4	160	123.0	12500
U16	550	190	338.0	34500	4	160	132.0	13500
U17	600	190	370.0	37800	4	160	147.0	15000
U18	660	190	406.0	41400	4	160	157.0	16000
U19	720	190	441.0	45000	4	170	172.0	17500
U20	780	190	479.0	48900	4	170	186.0	19000
U21	840	190	518.0	52800	4	170	201.0	20500
U22	910	190	559.0	57000	4	170	216.0	22000
U23	980	200	603.0	61500	4	180	230.0	23500
U24	1060	200	647.0	66000	4	180	250.0	25500
U25	1140	200	691.0	70500	4	180	270.0	27500
U26	1220	200	738.0	75300	4	180	284.0	29000
U27	1300	200	786.0	80100	4	180	309.0	31500
U28	1390	200	836.0	85200	4	180	324.0	33000
U29	1480	220	888.0	90600	5	190	324.0	33000
U30	1570	220	941.0	96000	5	190	333.0	34000
U31	1670	220	1024.0	104400	5	190	353.0	36000
U32	1790	220	1109.0	113100	5	190	378.0	38500
U33	1930	220	1168.0	119100	5	190	402.0	41000
U34	2080	240	1259.0	128400	5	200	422.0	43000
U35	2230	240	1356.0	138300	5	200	451.0	46000
U36	2380	240	1453.0	148200	5	200	480.0	49000
U37	2530	260	1471.0	150000	6	200	480.0	49000
U38	2700	260	1471.0	150000	6	200	490.0	50000
U39	2870	260	1471.0	150000	6	200	500.0	51000
U40	3040	280	1471.0	150000	6	200	520.0	53000

**TABLE 2 (continued)**  
**Towline and Hawsers for Self-propelled Ocean-going Vessels**

SI & MKS Units

Equipment Numeral	Equipment Number <sup>•</sup>	Towline Wire or Rope			Hawsers			
		Length, m	Breaking Strength,		Number	Length of Each, m	Breaking Strength,	
kN	kgf		kN	kgf				
U41	3210	280	1471.0	150000	6	200	554.0	56500
U42	3400	280	1471.0	150000	6	200	588.0	60000
U43	3600	300	1471.0	150000	6	200	618.0	63000
U44	3800	300	1471.0	150000	6	200	647.0	66000
U45	4000	300	1471.0	150000	7	200	647.0	66000
U46	4200	300	1471.0	150000	7	200	657.0	67000
U47	4400	300	1471.0	150000	7	200	667.0	68000
U48	4600	300	1471.0	150000	7	200	677.0	69000
U49	4800	300	1471.0	150000	7	200	686.0	70000
U50	5000	300	1471.0	150000	8	200	686.0	70000
U51	5200	300	1471.0	150000	8	200	696.0	71000
U52	5500	300	1471.0	150000	8	200	706.0	72000
U53	5800	300	1471.0	150000	9	200	706.0	72000
U54	6100	300	1471.0	150000	9	200	716.0	73000
U55	6500	300	1471.0	150000	9	200	726.0	74000
U56	6900	300	1471.0	150000	10	200	726.0	74000
U57	7400	300	1471.0	150000	11	200	726.0	74000
U58	7900				12	200	736.0	75000
U59	8400				12	200	736.0	75000
U60	8900				13	200	736.0	75000
U61	9400				14	200	736.0	75000
U62	10000				15	200	736.0	75000
U63	10700				16	200	736.0	75000
U64	11500				17	200	736.0	75000
U65	12400				18	200	736.0	75000
U66	13400				19	200	736.0	75000
U67	14600				21	200	736.0	75000

- For intermediate values of equipment number, use equipment complement in sizes and weights given for the lower equipment number in the table.

**TABLE 2**  
**Towline and Hawsers for Self-propelled Ocean-going Vessels**

US Units

Equipment Numeral	Equipment Number <sup>•</sup>	Towline Wire or Rope		Hawsers		
		Length, Fathoms	Breaking Strength, Pounds	Number	Length of Each Fathoms	Breaking Strength, Pounds
U6	150	98	22000	3	66	12100
U7	175	98	25100	3	66	13200
U8	205	98	29100	4	66	14300
U9	240	98	33700	4	66	15400
U10	280	98	39000	4	77	16500
U11	320	98	46500	4	77	17600
U12	360	98	50300	4	77	19800
U13	400	98	56200	4	77	22000
U14	450	98	62200	4	77	24200
U15	500	104	68800	4	88	27600
U16	550	104	76000	4	88	29800
U17	600	104	83300	4	88	33100
U18	660	104	91200	4	88	35300
U19	720	104	99200	4	93	38600
U20	780	104	107800	4	93	41900
U21	840	104	116400	4	93	45200
U22	910	104	125600	4	93	48500
U23	980	109	135500	4	98	51800
U24	1060	109	145500	4	98	56200
U25	1140	109	155400	4	98	60600
U26	1220	109	166000	4	98	63900
U27	1300	109	176500	4	98	69400
U28	1390	109	187800	4	98	72800
U29	1480	120	199700	5	104	72800
U30	1570	120	211500	5	104	75000
U31	1670	120	230000	5	104	79400
U32	1790	120	249500	5	104	84900
U33	1930	120	262500	5	104	90400
U34	2080	131	283000	5	109	94800
U35	2230	131	305000	5	109	101400
U36	2380	131	326500	5	109	108000
U37	2530	142	330500	6	109	108000
U38	2700	142	330500	6	109	110200
U39	2870	142	330500	6	109	112400
U40	3040	153	330500	6	109	116800

**TABLE 2 (continued)**  
**Towline and Hawsers for Self-propelled Ocean-going Vessels**

US Units

Equipment Numeral	Equipment Number <sup>•</sup>	Towline Wire or Rope		Hawsers		
		Length, Fathoms	Breaking Strength, Pounds	Number	Length of Each Fathoms	Breaking Strength, Pounds
U41	3210	153	330500	6	109	124600
U42	3400	153	330500	6	109	132300
U43	3600	164	330500	6	109	138900
U44	3800	164	330500	6	109	145500
U45	4000	164	330500	7	109	145500
U46	4200	164	330500	7	109	147700
U47	4400	164	330500	7	109	149900
U48	4600	164	330500	7	109	152100
U49	4800	164	330500	7	109	154300
U50	5000	164	330500	8	109	154300
U51	5200	164	330500	8	109	156500
U52	5500	164	330500	8	109	158700
U53	5800	164	330500	9	109	158700
U54	6100	164	330500	9	109	160900
U55	6500	164	330500	9	109	163100
U56	6900	164	330500	10	109	163100
U57	7400	164	330500	11	109	163100
U58	7900			11	109	165300
U59	8400			12	109	165300
U60	8900			13	109	165300
U61	9400			14	109	165300
U62	10000			15	109	165300
U63	10700			16	109	165300
U64	11500			17	109	165300
U65	12400			18	109	165300
U66	13400			19	109	165300
U67	14600			21	109	165300

• For intermediate values of equipment number, use equipment complement in sizes and weights given for the lower equipment number in the table.

This Page Intentionally Left Blank

PART

# 3

CHAPTER

## 6 Navigation

### CONTENTS

---

<b>SECTION 1</b>	<b>Visibility .....</b>	<b>275</b>
1	Navigation Bridge Visibility .....	275
1.1	Field of Vision.....	275
1.3	Windows and Their Arrangements .....	276
1.5	Unconventional Design .....	277
	FIGURE 1 .....	275
	FIGURE 2 .....	276
	FIGURE 3 .....	276
	FIGURE 4 .....	276
	FIGURE 5 .....	277

This Page Intentionally Left Blank



PART

3

CHAPTER 6 Navigation

SECTION 1 Visibility (1 July 1998)

1 Navigation Bridge Visibility

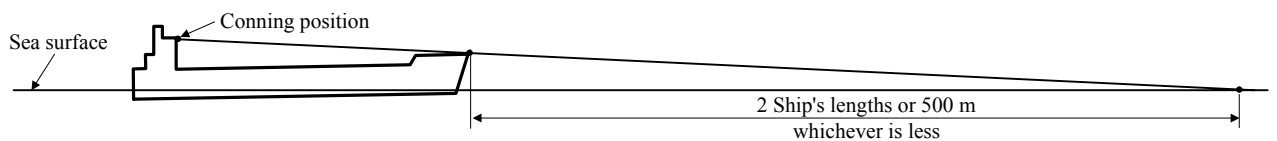
Vessels with the keel laid or in similar stage of construction on or after 1 July 1998, are to meet the following requirements with regard to the visibility from the navigation bridge, unless they are navigating solely the Great Lakes of North America and their connecting and tributary waters as far east as the lower exit of the St. Lambert Lock at Montreal in the Province of Quebec, Canada. Special consideration will be given to vessels that operate only on domestic or on short, limited, international voyages.

1.1 Field of Vision

1.1.1 Conning Position

1.1.1(a) The view of the sea surface from the conning position is not to be obscured by more than  $2L_f$  ( $L_f$  as defined in 3-1-1/3.3) or 500 m (1640 ft), whichever is less, forward of the bow to  $10^\circ$  on either side for all conditions of draft, trim and deck cargo under which the particular vessel is expected to operate. See 3-6-1/Figure 1.

FIGURE 1



1. A conning position is a place on the bridge with a commanding view and which is used by navigators when commanding, maneuvering and controlling a vessel.
2. Attention is drawn to flag Administrations requiring lengths of less than  $2L_f$ .

1.1.1(b) No blind sector caused by cargo, cargo gear or other obstructions outside of the wheelhouse forward of the beam which obstructs the view of the sea surface as seen from the conning position is to exceed  $10^\circ$ . The total arc of blind sectors is not to exceed  $20^\circ$ . The clear sectors between blind sectors are to be at least  $5^\circ$ . However, in the view described in 3-6-1/1.1.1(a), each individual blind sector is not to exceed  $5^\circ$ .

1.1.1(c) The horizontal field of vision from the conning position is to extend over an arc of not less than  $225^\circ$ , that is, from right ahead to not less than  $22.5^\circ$  abaft the beam on either side of the vessel. See 3-6-1/Figure 2.

### 1.1.2 Bridge Wing

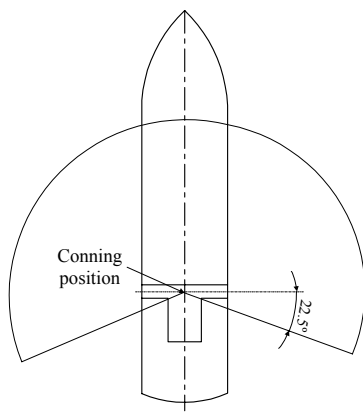
1.1.2(a) From each bridge wing, the horizontal field of vision is to extend over an arc of at least  $225^\circ$ , that is, from at least  $45^\circ$  on the opposite bow to right ahead and then from right ahead to right astern through  $180^\circ$  on the same side of the vessel. See 3-6-1/Figure 3.

1.1.2(b) The vessel's side is to be visible from the bridge wing.

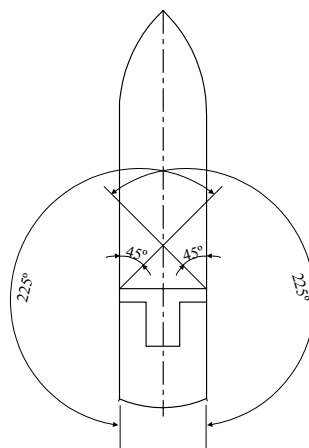
### 1.1.3 Main Steering Position

From the main steering position, the horizontal field of vision is to extend over an arc from right ahead to at least  $60^\circ$  on each side of the vessel. See 3-6-1/Figure 4.

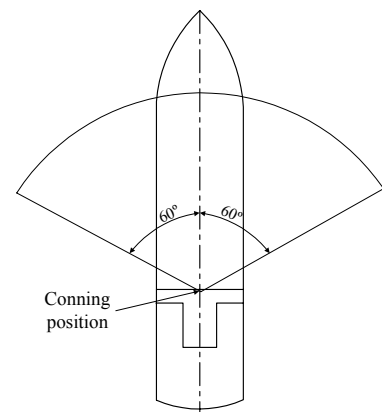
**FIGURE 2**



**FIGURE 3**



**FIGURE 4**



## 1.3 Windows and Their Arrangements

Windows and their arrangements are to meet the following requirements:

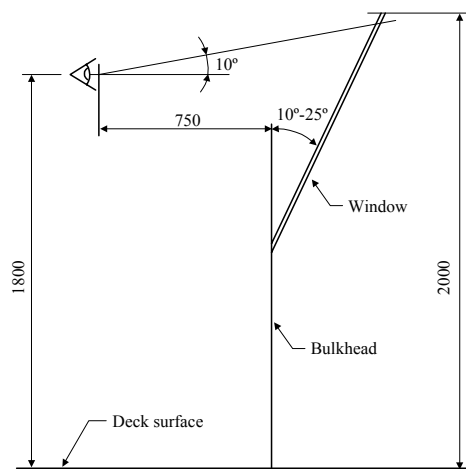
### 1.3.1 Framing

Framing between navigation bridge windows is to be kept to a minimum to meet the structural strength and stiffness requirements, and is not to be installed immediately in front of any workstations.

### 1.3.2 Inclination Angle

The bridge front windows are to be inclined from a vertical plane top out, at an angle of not less than  $10^\circ$  and not more than  $25^\circ$ , see 3-6-1/Figure 5.

FIGURE 5



### 1.3.3 Glass

Polarized and tinted windows are not to be fitted.

### 1.3.4 Clear View

At all times, regardless of the weather conditions, at least two of the navigation bridge front windows are to provide a clear view, and in addition, depending on the bridge configuration, an additional number of windows are to provide a clear view. To this end, the following, or equivalent, is to be provided:

*1.3.4(a) Sun Screens.* Sunscreens with minimum color distortion. These sunscreens are to be readily removable and not permanently installed.

*1.3.4(b) Wipers and Fresh Water Wash Systems.* Heavy-duty wipers, preferably provided with an interval function, and fresh water wash systems. These wipers are to be capable of operating independently of each other.

*1.3.4(c) De-icing and De-misting Systems.* De-icing and de-misting systems to be provided.

*1.3.4(d) Fixed Catwalk.* A fixed catwalk with guardrails, fitted forward of the bridge windows, to enable manual cleaning of windows in the event of failure of the above systems.

### 1.3.5 Lower Edge

The height of the lower edge of the navigation bridge front windows above the bridge deck is to be kept as low as possible. In no case is the lower edge to present an obstruction to the forward view as described in this Section.

### 1.3.6 Upper Edge

The upper edge of the navigation bridge front windows is to allow a forward view of the horizon, for a person with a height of eye of 1800 mm (5 ft 11 in.) above the bridge deck at the conning position, when the vessel is pitching in heavy seas. The Bureau, if satisfied that an 1800 mm (5 ft 11 in.) height of eye is unreasonable and impractical, may allow reduction of the height of eye but not to less than 1600 mm (5 ft 3 in.). See 3-6-1/Figure 5.

## 1.5 Unconventional Design

For vessels of unconventional design which cannot comply with the above requirements, arrangements are to be provided to the satisfaction of the Bureau to achieve a level of visibility that is as near as practical to those prescribed in this Section.

This Page Intentionally Left Blank

**7 Testing, Trials and Surveys During Construction – Hull****CONTENTS**

<b>SECTION 1</b>	<b>Tank, Bulkhead and Rudder Tightness Testing.....</b>	<b>281</b>
1	General .....	281
1.1	Application .....	281
1.3	Definitions .....	281
3	Test Procedures.....	282
3.1	General .....	282
3.3	Structural Testing .....	282
3.5	Air Testing .....	282
3.7	Hose Testing .....	282
5	Details of Testing .....	282
5.1	Hydrostatic Testing .....	282
5.3	Hydropneumatic Testing .....	282
5.5	Air Testing .....	283
5.7	Hose Testing .....	283
5.9	Other Methods of Testing.....	283
7	Application of Coating .....	283
7.1	Final Coating .....	283
7.3	Temporary Coating .....	283
TABLE 1	Testing Requirements for Tanks and Boundaries ...	284
TABLE 2	Additional Testing Requirements for Vessels or Tanks of Special Service .....	286
<b>SECTION 2</b>	<b>Trials.....</b>	<b>287</b>
1	Anchor Windlass Trials .....	287
3	Bilge System Trials .....	287
5	Steering Trials .....	287

<b>SECTION 3</b>	<b>Surveys</b> .....	<b>289</b>
1	Construction Welding and Fabrication .....	289
3	Hull Castings and Forgings .....	289
5	Hull Piping .....	289

PART

# 3

CHAPTER **7 Testing, Trials and Surveys During Construction – Hull**

SECTION **1 Tank, Bulkhead and Rudder Tightness Testing**

**1 General (1998)**

**1.1 Application (2002)**

All gravity tanks, excluding independent tanks of less than 5 m<sup>3</sup> (176 ft<sup>3</sup>) in capacity, and other boundaries required to be watertight or weathertight are to be tested in accordance with this subsection and proven tight or structurally adequate as follows:

1.1.1

*Gravity Tanks* for their structural adequacy and tightness,

1.1.2

*Watertight Boundaries Other Than Tank Boundaries* for their watertightness, and

1.1.3

*Weathertight Boundaries* for their weathertightness.

For the testing of cargo containment systems of liquefied gas carriers, the requirements in 5-8-4/10 will apply.

**1.3 Definitions**

1.3.1

*Structural Testing* is a test to verify the structural adequacy of the design and the tightness of the tanks.

1.3.2

*Air Testing* is a test to verify the tightness of the structure by means of air pressure difference.

1.3.3

*Hose Testing* is a test to verify the tightness of the structure by a jet of water.

#### 1.3.4

*Hydropneumatic Testing* is a combined hydrostatic and air testing wherein a tank is filled by water with air pressure applied on top.

#### 1.3.5

*Hydrostatic Testing* is a test to verify the structural adequacy of the design and the tightness of the tank's structure by means of water pressure, by filling water to the level as specified in 3-7-1/Table 1. Hydrostatic testing is the normal means for structural testing with exception as per 3-7-1/3.3.

### 3 Test Procedures (1998)

#### 3.1 General

Tests are to be carried out in the presence of the Surveyor at a stage sufficiently close to completion, after all attachments, outfittings or penetrations which may affect the strength or tightness of the structure have been completed, and before any ceiling and cement work is applied over joints.

Specific test requirements are given in 3-7-1/5 and 3-7-1/Table 1. For vessels or tanks of special service, additional requirements are given in 3-7-1/Table 2.

For the timing of application of coating in relation to testing, see 3-7-1/7.

#### 3.3 Structural Testing

Where structural testing is specified by 3-7-1/Table 1 or 3-7-1/Table 2, hydrostatic testing in accordance with 3-7-1/5.1 will be acceptable, except where practical limitations prevent it or where air testing is permitted by Note 1 to 3-7-1/Table 1. Hydropneumatic testing, in accordance with 3-7-1/5.3, may be approved in lieu of hydrostatic testing. Structural testing may be carried out after the vessel is launched.

Tank boundaries are to be tested at least from one side. Tanks to be tested for structural adequacy (see Note 1 to 3-7-1/Table 1) are to be selected so that all representative structural members are tested for the expected tension and compression.

#### 3.5 Air Testing

Air testing is to be in accordance with 3-7-1/5.5.

#### 3.7 Hose Testing

Hose testing is applied to structures not subjected to structural or air testing but required to be watertight or weathertight as specified in 3-7-1/Table 1. For the details of hose testing, see 3-7-1/5.7. Air testing or structural testing may be accepted in lieu of hose testing.

### 5 Details of Testing (1998)

#### 5.1 Hydrostatic Testing

Hydrostatic testing is to consist of a head of water to the level specified in 3-7-1/Table 1.

#### 5.3 Hydropneumatic Testing

When approved, the combined water level and air pressure used for hydropneumatic testing is to simulate the actual loading as far as practicable. The requirements and recommendations in 3-7-1/5.5 relative to air pressure will also apply.



## 5.5 Air Testing

All boundary welds, erection joints, and penetrations including pipe connections are to be examined in accordance with the approved procedure and under a pressure differential not less than 0.15 bar (0.15 kgf/cm<sup>2</sup>, 2.2 psi) with a leak indicating solution.

It is recommended that the air pressure in the tank be raised to and maintained at 0.20 bar (0.20 kgf/cm<sup>2</sup>, 2.9 psi) for approximately one hour, with a minimum number of personnel around the tank, before being lowered to the test pressure.

A U-tube with a height sufficient to hold a head of water corresponding to the required test pressure is to be arranged. The cross sectional area of the U-tube is to be not less than that of the pipe supplying air. In addition to the U-tube, a master gauge or other approved means is to be provided to verify the pressure.

Other effective methods of air testing, including compressed air fillet weld testing or vacuum testing, may be considered in accordance with 3-7-1/5.9.

## 5.7 Hose Testing

Hose testing is to be carried out with the pressure in the hose of at least 2 bar (2 kgf/cm<sup>2</sup>, 30 psi) during test. The nozzle is to have minimum inside diameter of 12 mm (0.5 in.) and located at a distance to the joint not exceeding 1.5 m (5 ft).

## 5.9 Other Methods of Testing

Other methods of testing may be considered upon submission of full particulars.

# 7 Application of Coating (1998)

## 7.1 Final Coating

### 7.1.1

*Structural Testing.* Final coating may be applied prior to the hydrostatic testing, provided an air test is carried out before the application of the final coating.

### 7.1.2

*Air Testing.* For all manual or semi-automatic erection welds and all fillet weld tank boundary connections including penetrations, the final coating is to be applied after air testing. For other welds, the final coating may be applied prior to air testing provided the Surveyor, after examination prior to the application of the coating, is satisfied with the weld. The Surveyor reserves a right to require air testing prior to the final coating of automatic erection welds and manual or automatic pre-erection welds.

### 7.1.3

*Hose Testing.* The final coating is to be applied after all required hose testing is completed.

## 7.3 Temporary Coating

Any temporary coating which may conceal defects or leaks is to be applied as specified for the final coating. This requirement does not apply to shop primer applied before fabrication.

**TABLE 1**  
**Testing Requirements for Tanks and Boundaries (1998)**

	<i>Structures to be Tested</i>	<i>Type of Testing</i>	<i>Hydrostatic Testing Head or Pressure</i>	<i>Remarks</i>
1	Double Bottom Tanks	Structural <sup>(1,2)</sup>	The greater of - to the top of overflow, or - to the bulkhead deck	
2	Double Side Tanks	Structural <sup>(1,2)</sup>	The greater of - to the top of overflow, or - to 2.4 m (8 ft) above top of tank <sup>(3)</sup>	
3	Deep Tanks or Cargo Oil Tanks	Structural <sup>(1,2)</sup>	The greatest of - to the top of overflow, - to 2.4 m (8 ft) above top of tank <sup>(3)</sup> , or - to the top of tank <sup>(3)</sup> plus setting of any pressure relief valve	
	Fuel Oil Bunkers	Structural		
4	Ballast Holds of Bulk Carriers	Structural <sup>(1)</sup>	<i>(2006)</i> The greater of - to the top of overflow, or - to 0.9m (3 ft) above top of hatch coaming <sup>(3)</sup>	See items 12 and 13 for hatch covers.
5a	Peak Tanks	Structural	The greater of - to the top of overflow, or - to 2.4 m (8 ft) above top of tank <sup>(3)</sup>	After peak tank test to be carried out after installation of stern tube.
5b	Fore Peak Voids (collision bhd.)	See Note 4	See Note 4	
5c	Aft Peak Voids	Air		
6	Cofferdams	Structural <sup>(5)</sup>	The greater of - to the top of overflow, or - to 2.4 m (8 ft) above top of cofferdam	
7	Watertight Bulkheads	Hose <sup>(6)</sup>		
8	Watertight Doors below freeboard or bulkhead deck	Hose		See 3-2-9/9.11 for additional test at the manufacturer.
9	Double Plate Rudder	Air		
10	Shaft Tunnel Clear of Deep Tanks	Hose		
11	Shell Doors	Hose		
12	Watertight Hatch Covers of tanks on combination carriers.	<i>(2006)</i> Structural <sup>(1,2)</sup>	The greater of: - to 2.4 m (8 ft) above the top of hatch cover, or - setting pressure of the pressure relief valve.	At least every 2 <sup>nd</sup> hatch cover is to be tested.
13	Weather-tight Hatch Covers, Doors and other Closing Appliances	Hose <sup>(6)</sup>		

**TABLE 1 (continued)**  
**Testing Requirements for Tanks and Boundaries (1998)**

	<i>Structures to be Tested</i>	<i>Type of Testing</i>	<i>Hydrostatic Testing Head or Pressure</i>	<i>Remarks</i>
14a	(2006) Chain Locker and Chain Pipe (aft of collision bulkhead)	Structural	(1 July 2003) To the top of chain pipe	
14b	(2006) Chain Locker and Chain Pipe (fwd of collision bulkhead)	Structural <sup>(7)</sup>	To the top of chain pipe	
15	Independent Tanks	Structural	The greater of - to the top of overflow, or - to 0.9 m (3 ft) above top of tank	
16	Ballast Ducts	Structural	Ballast pump maximum pressure or setting of any relief valve for the ballast duct if that is less.	
17	Hawse Pipes	Hose		

Notes:

- 1 (2006) Provided the structural similarity of a group of tanks is recognized by the Bureau and a representative tank as selected by the Bureau is structurally tested based on the design approval, air testing in accordance with 3-7-1/5.5 may be accepted. In general, structural testing need not be repeated for subsequent vessels of a series of identical newbuildings. Subsequent tanks may require hydrostatic testing, if found necessary, after the structural testing.
- 2 All cargo segregation boundaries in oil carriers and combination carriers and tanks for segregated cargoes of pollutants are to be hydrostatically tested.
- 3 (2006) Top of tank is the deck forming the top of the tank, excluding hatchways. In holds for liquid cargo or ballast with large hatch covers, the top of tank is to be taken at the top of the hatch coaming.
- 4 Hydrostatic testing to the damaged waterline but not less than the distance to the bulkhead deck.
- 5 Air testing in accordance with 3-7-1/5.5 may be accepted, except that hydropneumatic testing may be required in consideration of the construction techniques and welding procedures employed.
- 6 Where hose testing is impractical due to the stage of outfitting, air test or other alternate method of testing such as close visual examination and, where necessary, nondestructive test of all joints may be considered.
- 7 (2006) In general, structural testing need not be repeated for subsequent vessels of a series of identical newbuildings provided air testing in accordance with 3-7-1/5.5 is carried out. Subsequent chain lockers may require hydrostatic testing if found necessary after the structural testing.

**TABLE 2**  
**Additional Testing Requirements for Vessels**  
**or Tanks of Special Service (1998)**

	<i>Type of Vessels or Tanks</i>	<i>Structures to be Tested</i>	<i>Type of Testing</i>	<i>Hydrostatic Testing Head</i>	<i>Remarks</i>
1	Liquefied Gas Carriers	Ballast or Fuel Oil Tanks adjacent to or between Cargo Tank Hold Spaces	Structural	The greater of water head - to the top of overflow, or - to 2.4 m (8 ft) above top of tank	
2	Edible Liquid Tanks	Independent Tanks	Structural	The greater of water head - to the top of overflow, or - to 0.9 m (3 ft) above top of tank	
3	Chemical Carriers	Integral or Independent Tanks	Structural	The greater of water head - to 2.4 m (8 ft) above top of tank, or - to top of tank plus setting of any pressure relief valve	

PART

# 3

CHAPTER **7 Testing, Trials and Surveys During Construction – Hull**

SECTION **2 Trials**

**1 Anchor Windlass Trials** (2002)

Each windlass is to be tested under working conditions after installation onboard to demonstrate satisfactory operation. Each unit is to be independently tested for braking, clutch functioning, lowering and hoisting of chain cable and anchor, proper riding of the chain over the chain lifter, proper transit of the chain through the hawse pipe and the chain pipe, and effecting proper stowage of the chain and the anchor. The mean hoisting speed, as specified in 4-5-1/5.1.4, is to be measured and verified, with each anchor and at least 82.5 m (45 fathoms) length of chain submerged and hanging free. The braking capacity is to be tested by intermittently paying out and holding the chain cable by means of the application of the brake. Where the available water depth is insufficient, the proposed test method will be specially considered.

**3 Bilge System Trials**

All elements of the bilge system are to be tested to demonstrate satisfactory pumping operation, including emergency suction and all controls. Upon completion of the trials, the bilge strainers are to be opened, cleaned and closed up in good order.

**5 Steering Trials**

Refer to 4-3-4/21.7, 4-3-4/23.3 and 4-3-4/25.7, as applicable, for technical details of the steering trials.

This Page Intentionally Left Blank

PART

# 3

CHAPTER **7 Testing, Trials and Surveys During Construction – Hull**

SECTION **3 Surveys**

**1 Construction Welding and Fabrication**

For surveys of hull construction welding and fabrication, refer to Part 2, Chapter 4 and the *ABS Guide for Nondestructive Inspection of Hull Welds*.

**3 Hull Castings and Forgings**

For surveys in connection with the manufacture and testing of hull castings and forgings, refer to Part 2, Chapter 1.

**5 Hull Piping**

For surveys in connection with the manufacture and testing of hull piping, refer to Section 4-6-1.

This Page Intentionally Left Blank